

FLYING ACES

FACT
MODEL
BUILDING
FICTION

15¢

MAY

WHAT'S NEW IN THIS AIRWAR?

by MAJOR FREDERIC I. LORD



VOUGHT-SIKORSKY XF4U-1
"WORLD'S FASTEST FIGHTER"

Grahamberg

THOMAS McBRIDE FEATURE • "GET THAT AERO JOB" • NORSE AIR FORCE ARTICLE
DICK KNIGHT ADVENTURE • KERRY KEEN INTRIGUE NOVELET • P. PINKHAM
MODEL MAKING: NORTH AMERICAN FLYING SCALE • "COVERING UP" • AMA RULES

"TOPS" in beauty...performance...value»» these New

SCIENTIFIC

creations were designed for
NEW FLYING THRILLS!

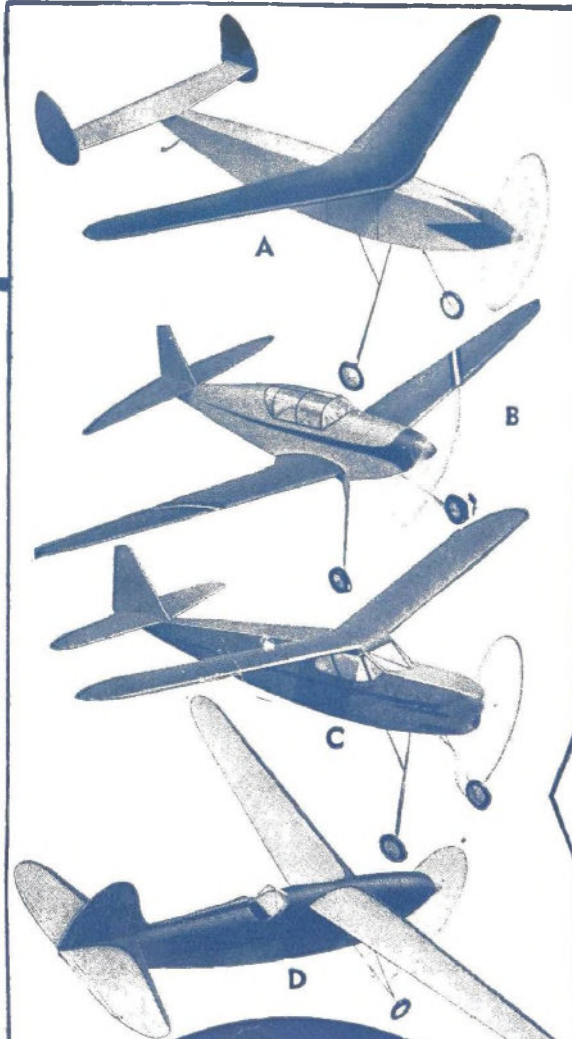

Get Your Copy of Scientific's
NEW 1941 CATALOG

Chock full of big bargains in
plane kits, motors, speedway
racers, speedboats, etc. Send

5¢



Introducing 4 New 30" Models

A. The WHIPPET

Incorporates such advanced features as: swept back wing, twin rudders, simple and efficient landing gear, adjustable and detachable wing. Complete kit, postpaid or at your dealer **50¢**

B. The BULLET

A pursuit type plane with a low, streamlined, tapered wing; movable tabs on tail surfaces; single strut landing gear; enclosed cabin. Complete kit, postpaid or at your dealer **50¢**

C. The Yellowbird

Employs the under chamber swept back wing—movable and detachable. A contest type model designed for consistent endurance flights. Complete kit, postpaid or at your dealer **50¢**

D. The CLARION

Wing is stationary and faired into the fuselage. Tail surfaces are designed with movable tabs, insuring easy directional control. Complete kit, postpaid or at your dealer **50¢**

GAS KITS

priced from **\$1.95**

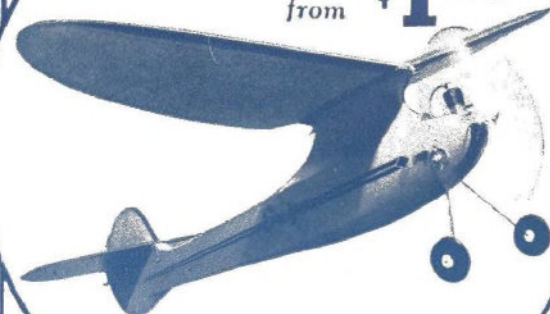

Illustrated: ENSIGN CLASS "B"
Wingspan—50" . . . Wing Area—
372 sq. in. . . Length over all—
34 1/4". Complete kit, less
motor, postpaid or at **\$2.95**
your dealer.

**SHOW
YOUR
COLORS!**



Build

Scientific's "ALL AMERICAN"

Boost America! Build this patriot of the air! Enjoy flights such as you have never experienced before! Designed to fly, it has consistently made long, graceful endurance flights of two miles and more! Its dashing, patriotic color scheme of red, white and blue will capture your heart! Complete kit, postpaid or at your dealer **\$1.00**



SCIENTIFIC MODEL AIRPLANE COMPANY

218-220 FA-5 Market Street, NEWARK, N. J.

Train AT AVIATION'S SCHOOL OF THE HOUR!

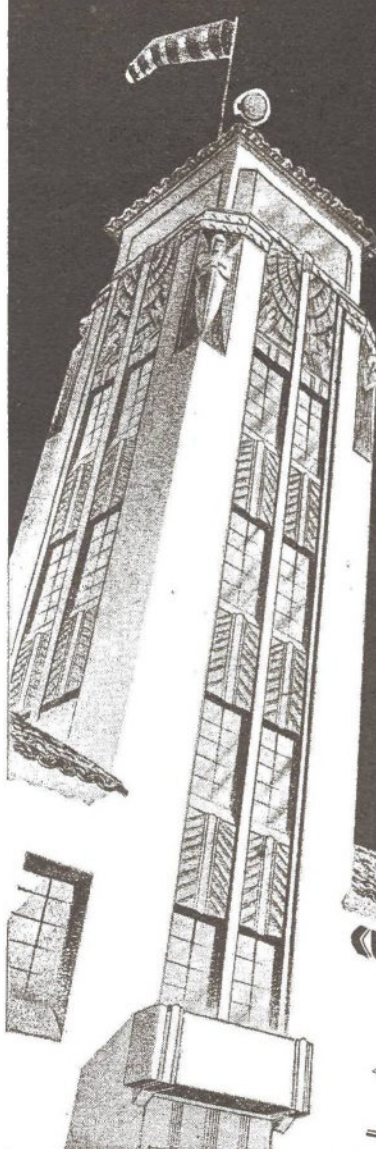

IN THE VERY CENTER AND A VERY IMPORTANT PART OF SOUTHERN CALIFORNIA'S GREAT AIRCRAFT INDUSTRY IS LOCATED CURTISS-WRIGHT TECHNICAL INSTITUTE.

Established in 1929, in twelve years this famous school has come to be recognized as the nation's leading institution in the training of Aeronautical Engineers and Master Mechanics. Mr. Donald Douglas, President of the great Douglas Aircraft Company, chose this school for his own son's training which pointedly indicates the high standing this school has attained in the aircraft industry.

You, who plan to invest in a course of career training to prepare yourself for the future, must determine in advance what the returns will be on your investment before you put cash on the line. This is imperative since your choice of a school in which to take your training will determine how much money you will make all the rest of your life. Your whole future in aviation depends on your training.

Curtiss-Wright Tec's career training is carefully designed to do just one thing:—TO MAKE MORE MONEY FOR YOU so upon graduation you can be independent and self-supporting for life. For years our hundreds of successful graduates have proven that Curtiss-Wright Tec training gets results and always pays. It has pro-

vided them with a profitable occupation and secure future since it trained them in advance for the highest position they could ever expect to occupy. It can do the same for you.

Aviation needs trained men. They are in demand and at a premium. Advancements for them are rapid, especially here in Southern California where there are over a billion dollars in unutilized aircraft orders on hand and where over fifty per cent of all aircraft manufactured in the United States is made. You can get in on the ground floor by training now, BUT you must choose the right school for your training.

Our graduates are obtaining immediate employment and the demand for them far exceeds the supply. We honestly believe that every student who enrolls here will be able to obtain, with our assistance, immediate employment upon graduation. This school has never guaranteed or promised positions for its graduates, but practically every graduate has obtained immediate employment, and is advancing steadily.

WARNING!—"don't miss the boat." The greatest opportunity of your lifetime exists today! There never was such an opportunity in aviation for you; there may never be another. A position awaits you. Insure for yourself a steady income and independence for life. Send in your enrollment today before you "miss the boat."

OFFERING SPECIALIZED AND PROVEN TRAINING IN
AERONAUTICAL ENGINEERING
AND MASTER MECHANICS

No Flying Involved

CURTISS-WRIGHT TECHNICAL

THIS TOWER OVERLOOKS AVIATION'S MOST DISTINGUISHED SCHOOL OF AERONAUTICS

**CURTISS WRIGHT
TECHNICAL INSTITUTE**



GRAND CENTRAL AIR TERMINAL 1227 AIRWAY GLENDALE (LOS ANGELES) CALIF.
UNDER PERSONAL SUPERVISION OF MAJOR C. C. MOSELEY, OWNER, SINCE ITS ESTABLISHMENT IN 1929

Contractor to the U. S. Army Air Corps

BE WISE—PROTECT YOUR FUTURE

MAIL TODAY

WITHOUT COST OR OBLIGATION
SEND ME FULL INFORMATION
AND CATALOG ON THE
COURSE CHECKED BELOW

DON'T DELAY

- AERONAUTICAL ENGINEERING COURSE
- MASTER AVIATION MECHANIC COURSE
- SPECIALIZED ENGINE COURSE
- SPECIALIZED AIRPLANE COURSE
- POST GRADUATE AERONAUTICAL ENGINEERING COURSE
- SPECIALIZED AIRCRAFT SHEET METAL COURSE
- AERONAUTICAL DRAFTING COURSE, HOME STUDY
- AIRCRAFT BLUE PRINT READING COURSE, HOME STUDY

NAME _____

ADDRESS _____

CITY _____

STATE _____

FA-5

— THEY ADVERTISE — LET'S PATRONIZE —

Fabric covered Curtiss biplane SOC scouts fitted with floats are used quite extensively by the Coast Guard.



Lieut. Thomas McBride

who fought for France until that country was defeated by Germany, on page 10 tells the truth about Hitler's air force. Many articles of this type have been written, but here at last is the inside story by one who knows!

FLYING ACES

A. A. WYN, *Editor*

DAVID C. COOKE, *Managing Editor*

VOLUME XXXVIII

MAY, 1941

NUMBER 2

FACT AND FICTION

WHAT'S NEW IN THIS AIRWAR?	Major Fred Lord	4
How the air aspect has changed.		
DEBUNKING HITLER'S LUFTWAFFE	Lieut. Thomas McBride	10
Here's the real, inside story.		
RAIDER WINGS IN THE PACIFIC	Donald E. Keyhoe	14
A strange voice spoke from nowhere!		
PASS THE PHYSICAL AND FLY	Capt. J. G. Levine	20
The Air Corps wants you—if you're fit.		
SKY SABOTAGE	Arch Whitehouse	24
Kerry Keen seeks a stolen squadron!		
HOW BOEING BUILDS THEM		27
Work progresses on the 314-A's.		
GET THAT AERO JOB	George H. Tweney	28
There are plenty openings in the industry.		
NORSE AIR FORCE TRAINS IN CANADA	James Montagnes	31
A new air force to combat Hitler.		
DAWN PETROL	Joe Archibald	32
Phineas gasses the Allied red tabs!		
DESIGN FOR FLYING	Charles Yerkow	35
Engineers have a really hard task.		
OBEDY THAT HUNCH!	Manuel Buaken	60

MODEL MAKING

WITH THE MODEL BUILDERS		40
SPITFIRE 3-VIEW	Leonard Wieczorek	41
ARMY BC-1	Milton Kahn	42
COVERING UP	Peter Bowers	47
NEWS OF THE MODELERS		48
"WINDJAMMER" STICK	Hank Brody	50
HOWARD TRAINER	Milt Kahn	52
STREAMLINE YOUR NAME	Ray Weeks	53
VULTEE V-11GB SOLID	Jack Kolton	54
LOGGING THE MOTOR MARKET		56
YOU SAID IT!		57
WORKBENCH TIP		57

DEPARTMENTS AND FEATURES

FLYING INTO FOCUS	8	IN THE SLIPSTREAM	30
DOWN MEMORY'S RUNWAY	13	FLYING ACES CLUB NEWS	36
KNOW AMERICA'S PLANES	17	JOIN THE FLYING ACES CLUB	38
MODERN PLANES ALBUM	18	ALL QUESTIONS ANSWERED	39
ON THE LIGHT PLANE TARMAC	22	IN OUR NEXT ISSUE	57

Cover Painting by August Schomburg

Published monthly by Magazine Publishers, Inc.; office of publication, 29 Worthington St., Springfield, Mass. A. A. Wyn, President, Editorial and executive offices, 67 W. 44th St., New York. Entered as second-class matter, Nov. 14, 1928, at Springfield, Mass., under Act of March 3, 1879. Title registered in U. S. Patent Office. Copyright, 1941 by Magazine Publishers, Inc. Nothing may be reprinted without permission of the publishers. Manuscripts will be handled with care, but this magazine assumes no responsibility for their safety. For advertising rates address FLYING ACES Magazine, 67 W. 44th St., New York City.

Subscription rate: \$1.50 for twelve issues in the United States, \$1.75 in Canada; and \$2.50 in all other foreign countries. Single copies, fifteen cents.

(in 4 to 14 months)
THIS TRAINING places YOU IN AVIATION



**Master Mechanics
IN 1 YEAR**



**Aeronautical Engineering
IN 14 MONTHS**

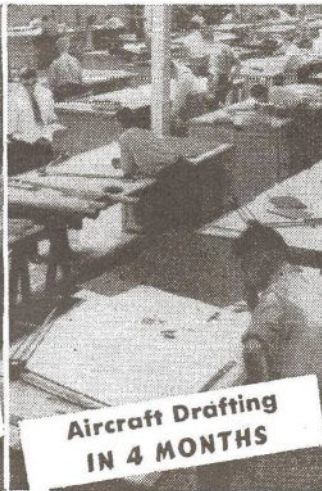

**Aircraft Drafting
IN 4 MONTHS**



**Production Mechanics
IN 4 MONTHS**

WE CAN'T SUPPLY THE DEMAND FOR OUR GRADUATES

"I am a California Flyers Graduate." It means something to say that. It means that aviation wants you to the extent that over 96% of all California Flyers graduates are employed in the industry and that it is impossible to supply the demand for our graduates. It is a passport into aviation. Secondly, it means that you are a man marked to succeed like the California Flyers graduates before you. And that is what *really* counts.

Why does a California Flyers man stand so high? It is obvious once you have heard the complete story of this famous school. Its founders believe that aviation should be taught in a school where the student remained an individual—learning aviation as it pertains to his individual ambitions and qualifications, and by so doing preparing *him* for the responsibilities of leadership. This way the graduate is prepared to meet today's aviation problems and to contribute to tomorrow's aviation advancement. This is the way today's leaders learned. Only this way can a training program be built for the industry, on industry's specifications. They believe too, that the entire field of aeronautics:—engineering, mechanics and piloting are all closely interwoven and that a student should train in a school that teaches all of these important divisions. Above all, they believe that aviation should be taught in an environment of aviation activity, taught where the greatest aviation developments originate, taught where there is the greatest number of men actively engaged in aviation. This is why California Flyers is located in the heart of the world's aviation capital on the world's busiest testing field.

If this is the kind of school that you would like . . . friendly, efficient, modern and thorough; an aeronautical school operated by practical aviation men, you will be most interested in reading the *complete* story of California Flyers in the new 64-page catalog which tells today's story of aviation at work, complete details of the training courses and just what it takes to be a *California Flyers man*.

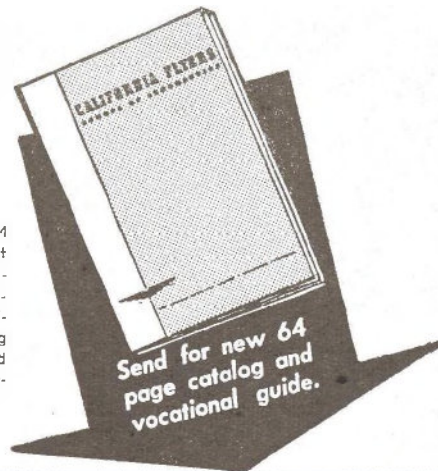

• Write for new 64 page catalog, get complete information on all of California Flyers' aviation training courses, tuition and employment opportunities.

CALIFORNIA FLYERS, INC.
 GOVERNMENT APPROVED
SCHOOL OF AERONAUTICS
 LOS ANGELES MUNICIPAL AIRPORT, INGLEWOOD, CALIFORNIA

LEARN ABOUT THIS COMPLETE RANGE OF PRACTICAL CAREER COURSES

CALIFORNIA FLYERS, INC., School of Aeronautics, Dept. F.A.-5
 Los Angeles Municipal Airport, Inglewood, California

Please send me your catalog and complete information on training, tuition, living conditions and employment opportunities. I am over 16 and interested in the subjects, checked:

- Aeronautical Engineering
- Production Mechanics (Aircraft sheet metal)
- Instrument and Radio Beam Flying
- Instrument Technician
- Airline Piloting
- Aircraft Drafting
- Master Mechanics

Name _____ Age _____

Address _____

City _____ State _____

Approved by the Civil Aeronautics Authority of the United States Government for Flight and Ground and Master Mechanics Courses.

What's New

The Nazis drop flares to light up London at night. The same thing happened in '18.

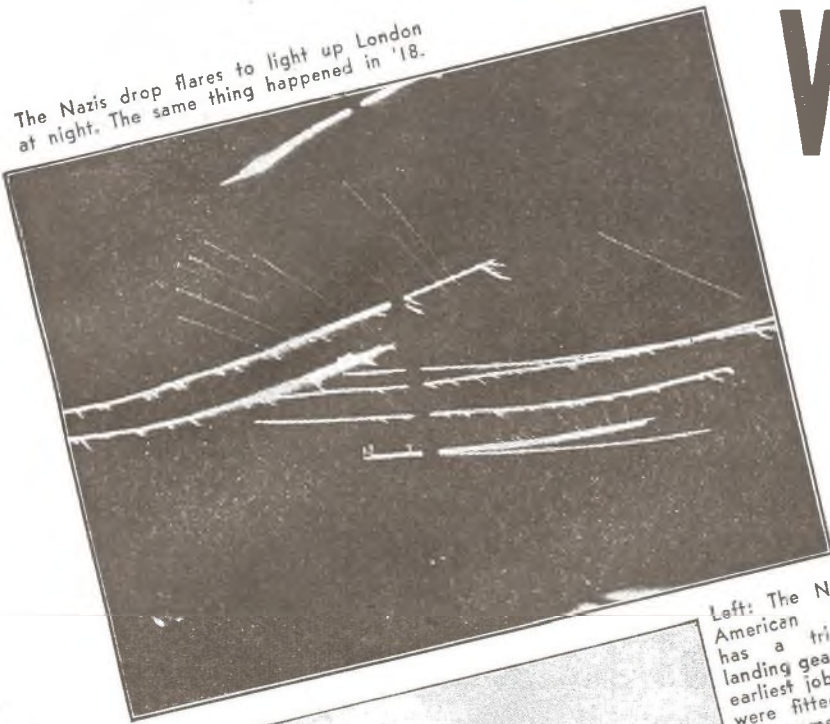

Left: The North American B-25 has a tricycle landing gear. The earliest jobs also were fitted with the same type undercarriage

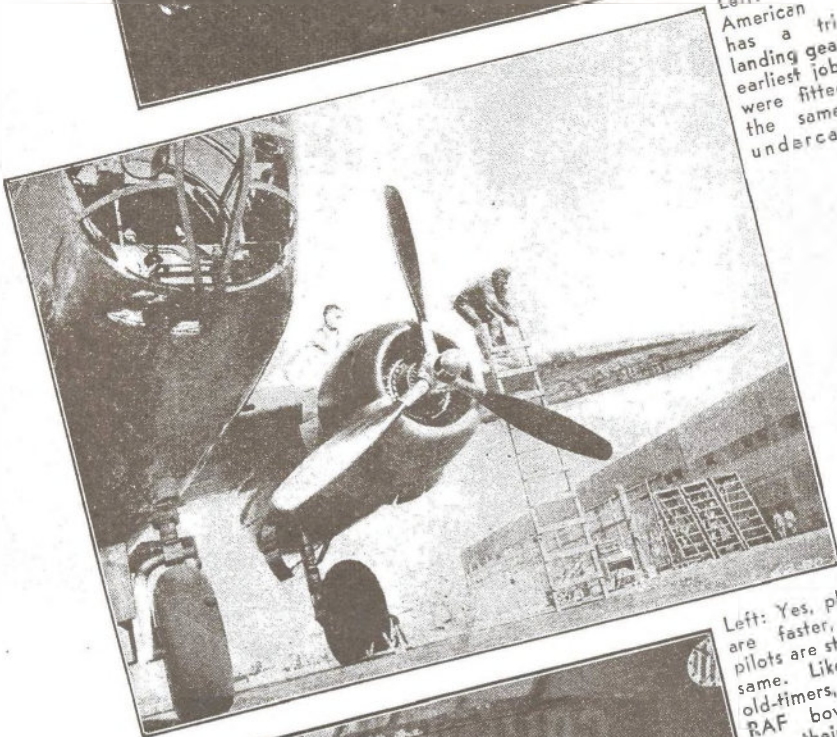

Left: Yes, planes are faster, but pilots are still the same. Like the old-timers, these RAF boys talk over their recent aerial scramble.



Editor's note: As we go to press, word comes through that Major Lord has been commissioned in the RCAF.

THE TRITE saying, "There's nothing new under the Sun," is familiar to all of us. The ancient Hindus had a profound knowledge of serums and bacteria only to be "discovered" by the Western world in the 19th Century. Gunpowder and the compass were used by the Chinese long before the white man thought of them. A crude steam engine was demonstrated long B. C. in Egypt, to be re-discovered with the aid of a steam kettle and a lady's skirt a couple of thousand years later.

Writings have been unearthed stating that in ancient India the enemy caused panic and consternation when they floated overhead on the wings of huge birds. Perhaps they had a knowledge of gliders or even some other method of flying as yet unknown to us.

Writers of the present war are prone to emphasize many phases and weapons as innovations or discoveries of today, when actually there are but very few things that weren't brought out during 1914-1918. Perhaps they weren't employed to the large extent they are today but they nevertheless had been used.

In the last few years we have heard a lot about motor-cannon. Then multiple cannon were installed in the wings. The caliber increased to 20 mm., then 25 mm., and finally America proudly boasted of actually having installed a 37 mm. cannon aboard a few airplanes. Romantic writers described the new terrors of air fighting. This would revolutionize aerial tactics, and so on. Yet France during the World War had mounted 37 mm. cannon on some of her Spads.

When you think of guns, you think of armor. Again you believe this to be something new. In "those days," we probably didn't have ships armored by the factory, but the individual pilots usually did their own armoring, starting with a stove lid under the seat and eventually working up to something really protective.

I remember a German Rumpler which had been systematically trench-raiding the British lines for days. Several times the squadron had emptied its guns into it without effect. When we finally told our commander that it must be an armored ship, we were ordered to the firing pits and told to learn to shoot straight.

We eventually forced that plane down on our side of the lines and discovered that the pilot was completely enclosed in armor. To compensate for this weight, he flew without an observer and instead had a straw dummy in the observer's seat. Here a gun was mounted to fire promiscuously to the rear to scare us off. This was operated by a Bowden control from

in this Airwar?

Many so-called military experts say that this new Nazi War is different from any embroglio of the past. But just how much has the air aspect changed? Major Lord tells you here.

by Major Frederic L. Lord

the pilot's pit up front.

American manufacturers are only today waking up to the necessity of self-sealing gasoline tanks, yet in the last fracas plenty of ships had them. Other machines had tanks which could be dropped in event of fire or forced landing.

Air brakes and flaps were then crude but they did work. I remember an old post-war Sopwith one-and-one-half strutter I was first given when I flew in North Russia. Sections of the wings near the fuselage seemed movable and I asked what they were. I was told they were air-brakes or flaps, depending on how they were adjusted by the pilot.

WE ARE now finding out that a tricycle landing gear permits airplanes to just simply fly to earth without the trouble of holding them off to get the tail down. But wasn't the three-wheel way one of the earliest systems?

Both the French and the British complained when modern American pursuits were delivered with an armament of but two guns. Yet I

remember a Dolphin squadron in the RAF with four guns firing forward and two firing upward from swivel mounts. And all our observers had twin swivel guns as compared with today's too-prevalent lone gun for rear protection.

Parachute troops might be new, but in the World War we also used the chute behind the enemy lines. A chutist would be seated on the wing of a night-flying F.E.2B and flown over German occupied territory. Strapped to his chest would be a crate of carrier pigeons to be released from time to time with information for the Allies. These "umbrella men" were usually natives of that territory. None knew a thing about flying or had previously worn a parachute and would be terror-stricken when ordered to slip off into nothingness. In this case, the pilot

would poke them off with a long stick he carried for the purpose. If a pigeon returned in a few days, we knew he had landed without injury.

The Stuka and dive-bombing tactics of this war are merely mass application of World War tactics. Most single-seaters carried eight 20-pound bombs. These ships had no bomb sights, so we either just dropped the projectiles at random or used our Aldis gun-sights in a vertical dive on the target. In this manner, troops on the march, trains, and ammunition dumps were attacked.

Just as an animal or a savage is frightened by unknown or terrible sounds, so is the modern man also affected. The Nazis knew this, and to make their dive-bombers even more terrifying they used the screech-bomb.

I remember experimentation with similar weapons in the RAF in 1918. A small bomb might be heard dropping a half mile distant, but after the British added a couple of wires from fin to fin these bombs screamed like a fire whistle as they descended. Then, even from a couple of miles away, they sounded as though they were headed right for one.

Today, England fears an invasion from the air. Only recently a British Major, who has accurately foretold events of the war, warned England to expect 200,000 parachutists to drop. This, he stated, would occur after terrific air bombardments. The Nazis would know each individual objective they were to take. They would scatter in groups of threes, and armed with light machine guns they would take

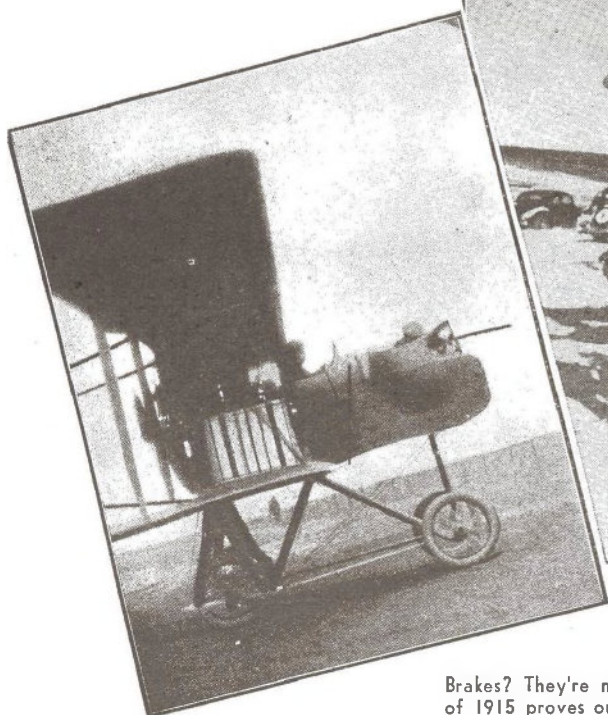

Here, the Army takes delivery of a cannon-carrying Bell P-39 Airacobra. In the First World War, a Spad was fitted to carry a cannon.

Brakes? They're nothing new, either. This old friedrichshafen FF-43 of 1915 proves our point. Also note auto-type landing gear system.

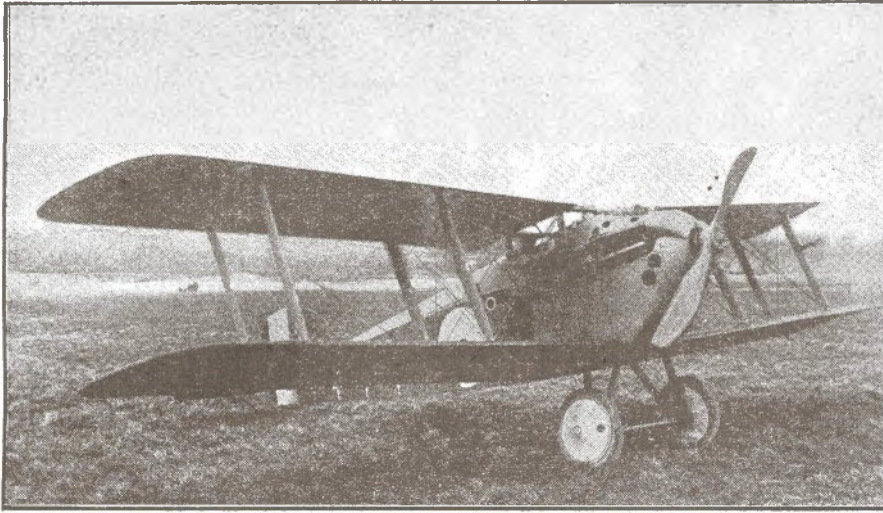

important cross-roads, farms, airports, and other points. To overcome these soldiers, entrenched with machine guns, it would require an attack by forty to fifty men of which thirty per cent would be wounded or killed. Allowing for casualties among the "umbrella men," this would mean that England would require an army of over a million to repel this invasion and then it wouldn't be certain as Hitler would, at the same time, launch a frontal attack.

This military expert also warned that the Germans might make this invasion with large gliders carrying twenty-five soldiers each. These would be towed by bombers which would harass the country after the gliders landed.

That this threat is generally accepted by the defenders was reflected by Prime Minister Winston Churchill's speech of February 8th in which he warned the people of possibility of an invasion by gliders in the near future. If this did occur, it really would be something new in warfare.

BUT GETTING BACK to everyday practices: We see photographs of pilots racing for their machines as word comes through that the Nazis are crossing the channel. Within three minutes, the proud claim is, twelve Spitfires or Hurricanes are in the air. One might believe this unusual, but it's not. During the last fracas a phone call would come in that a German plane was operating over a certain location. In three minutes or less, a formation would be off the ground to intercept the enemy. And in those days there were no self-starters, remember.

Air Commodore Bishop, the Canadian Ace, after returning from England recently said in a radio address that he found present-day aerial tactics just about what they were during 1914-1918. The only difference was that the speed of the airplanes necessitated a larger circle when maneuvering.

As in the World War, formations today break up after the first contact and go into the good old dogfight. And while loops, spins, and renversements may be indulged in when prac-

ticing, individual fighting still means the old vertical turn. The one who can make the shortest vertical still wins the battle. Other maneuvers are seldom practiced because there is always a moment when the maneuver must be completed and when the controls cannot be reversed. At that moment the enemy may get in a burst.

Today, the Sun and the clouds are

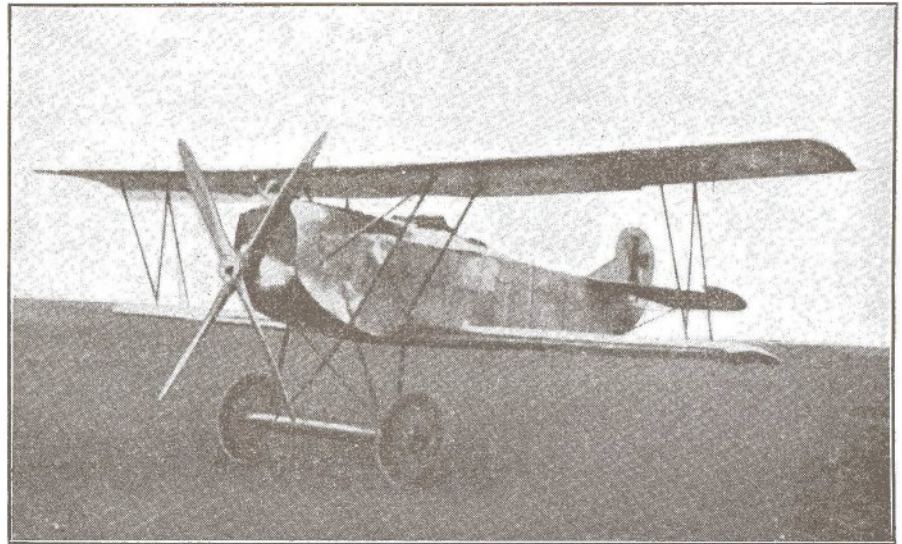

still used to hide in and pilots with initiative learn individual tricks to employ. Most of you have read all about modern theories of mass formations but would probably like to know of some actual practices of the individual. Just how does one use the Sun and how can you hide in a cloud?

I found it rather difficult to hide an entire formation in the Sun because the enemy is constantly expecting an attack from there. So I liked to work alone, and the bigger the enemy formation the better I liked it. They would be expecting an attack from a formation instead of a lone plane, and this gave me just the advantage I wanted.

If the enemy formation was patrolling a definite beat, I would watch it from such a distance that they looked like mere specks. I'd learn just where the end of their patrol was and just where they made their turn to

"Back in the old days," says Major Lord, "we used our Dolphins as dive-bombers. That was twenty-two years before the German Stukas."

retrace their track. Then I'd climb up into the Sun and wait for their return.

The dive would be so timed that I'd be among them just as they were turning. At that moment most of the enemy pilots would be concentrating on maintaining formation instead of watching overhead. If perfectly timed, my ship would be among them just as every plane was banking and not quite sure where the next one was. As my machine would go through their formation with guns open, there would be further confusion as the enemy would think this was only the first plane of a formation dropping down on them. Using the great speed built up in the dive to pull back on the stick and zoom through the formation, another burst could be got in. If these two bursts gave no results, the best thing to do then was to get away from there before they collected their wits and let you have it from all sides.

The same tactics worked with

As for the four-bladed props being used on military machines, look at this Fokker V-22. S.E.5's were also fitted in this manner.

bombers, only in this case one had to figure out the enemy's objective and attack just as they were concentrating on the target. The only drawback to this was that, though you might get the enemy bomber, his bombs frequently got the target, too.

A GLANCE at my log book shows the remark, "Drifted with cloud. Got wily Hun over Lys." And here are the details of that:

For several days a German two-seater had been doing artillery shoots on our positions. Each time I tried to get near him, he'd dive for earth and hedge-hop for home and safety.

Then one day while again stalking him I saw a cloud drifting toward the German lines and the artillery

bus. I climbed above the cloud and just flew circles there, biding my time, while the cloud drifted serenely along. When I figured the cloud was over friend Hun, I put my nose down and dived through it. And when I emerged, there was the fat two-seater but a few hundred feet away. He never knew what hit him—and I had learned another stunt for the book.

I taught this trick to another pilot of the squadron and he tried it but with different results. He drifted along with the cloud when he was out after an ammunition dump. Diving through the cloud he went into a spin and when he came out of it he found himself right in front of a Fokker formation heading for our lines and a scrap. He got away, but his ship was riddled and he was cured of that stunt.

We also hear a great deal today about the efficiency of our anti-aircraft guns and how they can bring down a ship on the fifth or sixth shot. Well, they can—when the target is towed in a straight line at a known height and speed. In actual combat, however, it's a different story.

When I went to Spain in 1936, I was pretty worried about Archie. I'd listened to army lectures by anti-aircraft gunners and their cocksureness had put the wind up me. But in that blitzkrieg rehearsal, I found that the best Nazi guns were just as easily fooled as in the days of 1914-1918.

Returning from a bombing raid, I was picked up by what I later found out was the best anti-aircraft battery the Nazis had in the Basque country.

My observer was a practical joker, and while we were calmly sailing along I felt a thump in the ship. I concluded my Spanish friend had kicked the flooring in fun and I paid no attention. A moment later the Breguet again was jolted. I squirmed around in my seat and kept an eye on my friend, but he only grinned and pointed off toward where we'd

seen a Heinkel a little earlier. Then there was a terrific explosion immediately beside us and the smoke of Archie drifted past. Had I not slightly veered while flying looking over my tail, that shot would have got us. The other two were the thumps I had felt in the ship.

Then began the old game of count and turn. I figured it took about five seconds to range, fire, and have the projectile reach us. I headed straight for our lines and counted the seconds. At five, I turned. Where I would have been were a number of bursts. Now I headed down the lines and again counted and turned, and again the bursts missed us. It was merely a game of me guessing where the gunners guessed I would be and then not being there at all. They soon gave up the game and I flew peacefully on.

Today, the British find that it really takes not five but around a thousand anti-aircraft shots before they register a hit.

ANOTHER thing that must soon reach its limit is the cry for more speed, more horses, more fire-power. It's a vicious circle.

To overtake the bomber, the fighting plane must have more speed. This means more horsepower. Then when they have the speed, the time of a machine gun burst is reduced, so they stick on more guns. When they get more guns, they need more horse-

power again. And so it goes on.

The Hurricane and Spitfire with their 1,050 h.p. and eight machine guns were just about tops. But as the war went on even more guns were required to "chop 'em down." Now Britain is coming out with a single-seater fighter of 2,000 h.p. and twelve guns and two cannon. Germany will rival that and then the race will be on.

The fast, heavily-armed ship will be necessary, but I predict that if the war lasts a couple of years more a new type of fighter will come out. It will be light, much slower, and very maneuverable. It will be almost reverting to World War machines. This fighter will be able to turn inside the circle of the faster craft and easily get on the speedy ship's tail. It will be able to easily avoid the dive of the 400 m.p.h. job and be able to do maneuvers close to the ground. Already the necessity for such a ship is felt to combat the slow, low-flying army cooperation planes.

Speed is not essential to win a combat. A hundred-mile-per-hour job can have its nose pointed at a ship coming at it at 400. The bullets of the slow machine will reach the other one just as fast, and the slower craft will be able to keep its sights on the target better.

Just as aerial fighting is believed by some to be entirely new with this war, so do others think that aviation was born with the Wright brothers.

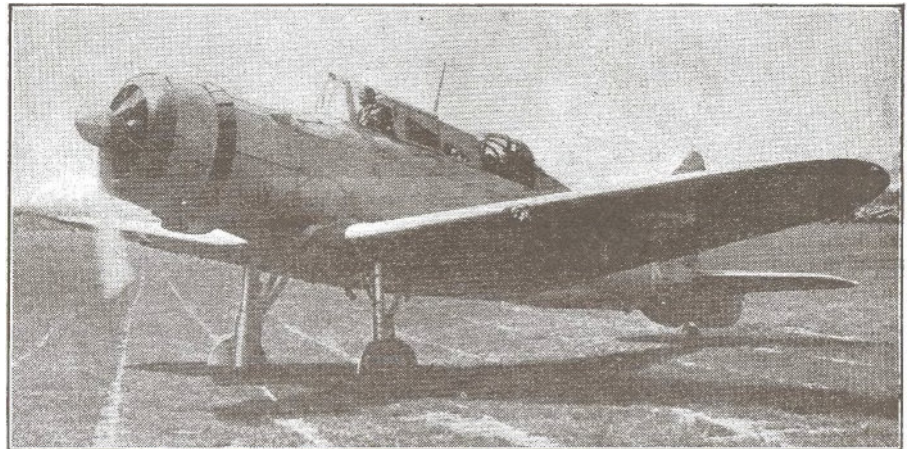

Below: The Westland Lysander is reported to be excellent for combating Messerschmitts. That again brings back the slow ship point.

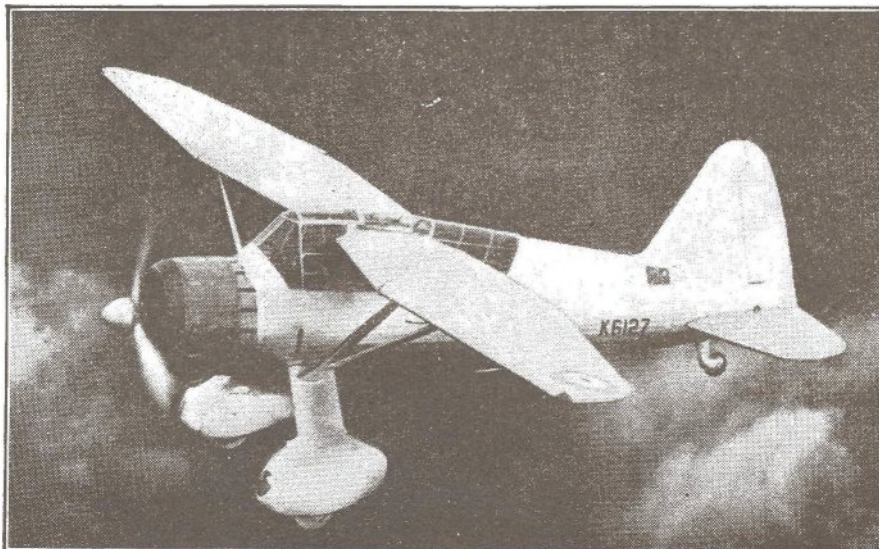

Above: The Roc has a retractable undercarriage, but the system is ancient. Leonardo Da Vinci invented a folding gear back in 210 B.C.

As a matter of fact long before that first flight there was a meeting of the International Conference of Aerial Navigation. In 1784 there was a discussion of Montgolfier's aerial achievement, and way back in 1676 a Latin book discussed the theories of displacement and mentioned *aero nautica*.

So you who have familiarized yourselves with the practices of other aerial warfare of 1914-1918 are still in the swim regardless of how dizzy you might become trying to follow the intricacies of modern theorists.

No, I repeat that this airwar is not different!

THE END

FLYING INTO FOCUS

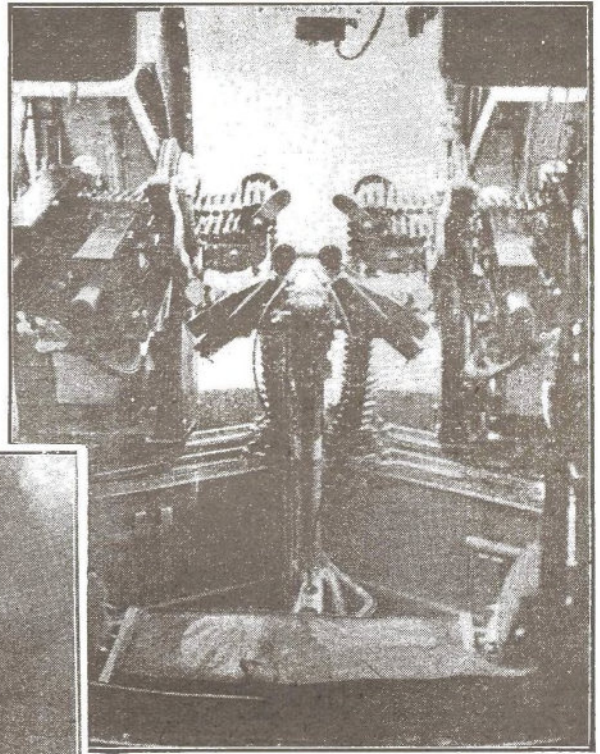

Four rifle-caliber guns are mounted in the tail turret of the RAF's Whitley bomber. The rate of fire is 4,800 rounds per minute—which is plenty! Note the four huge ammunition boxes in the rear.



Believe it or not, this is the way parachute troops are trained! U.S. Navy boys at Lakehurst, N. J., jump from a platform to acquaint themselves with the fall they will receive when actually landing with a chute. This is only one of the many things to be learned before the first jump from a Douglas.

Here we have another view of the Bell XFM-1A Airacuda presented in Modern Planes Album last month. Alterations over the original model include a tri-cycle landing gear arrangement and larger airscoops for the twin Allison engines. Note well with swinging doors to accommodate the front wheel when folded.

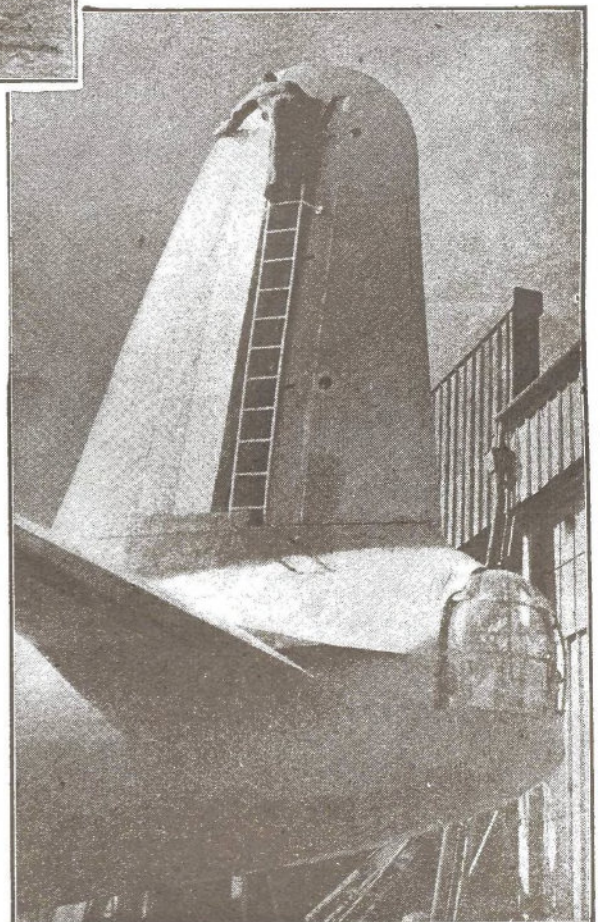
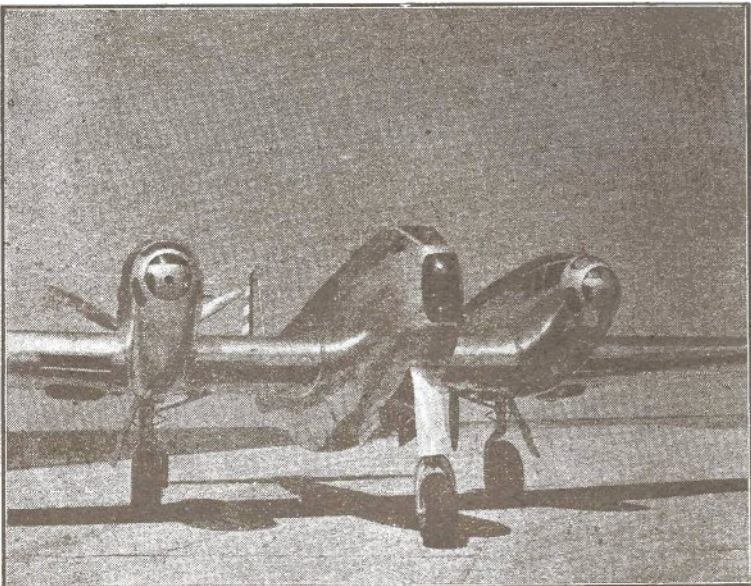

Getting up in the world. A Fleet Air Arm mechanic inspects the antenna of a Short Sunderland patrol boat prior to flight. The ladder, of course, is removable. Sunderlands are used for convoy work.

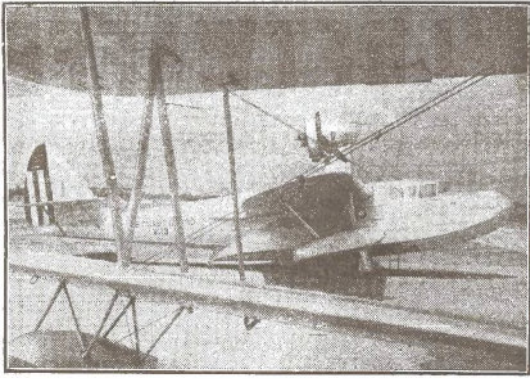

There are still a few of the old General Aviation PJ-1's in the Coast Guard. This one is at Floyd Bennett Field.

Right: Vought has come a long way since their Ve.7 advanced trainer (above) of 1918. Their latest product is the XF4U-1, which was recently rated as "the world's fastest fighter." Speed is more than 400 m.p.h.

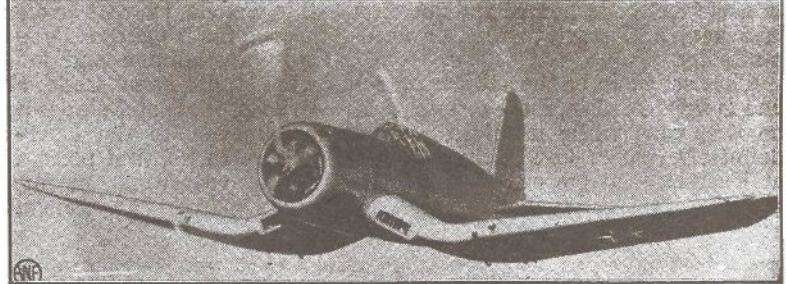
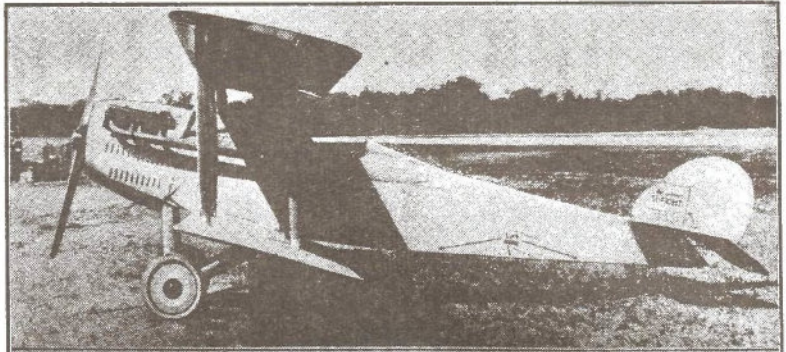

The control pit of an RAF bomber. These flyers are set for a foray into Germany. (March of Time photo)

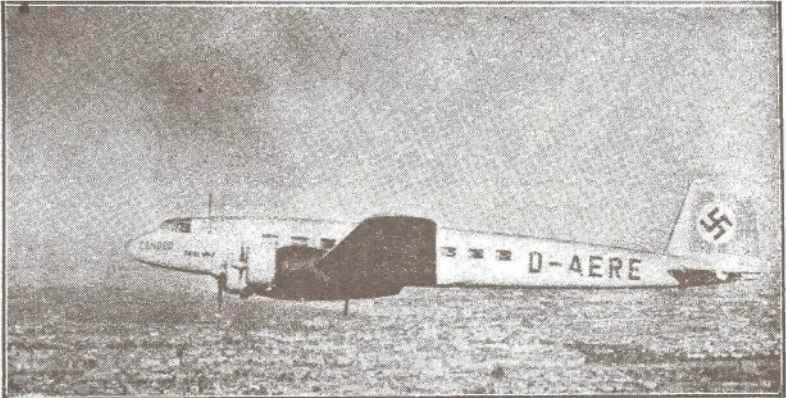

Above: A few years ago the Focke-Wulf Condor made a non-stop hop from Berlin to New York, minus passengers. Now, according to reports, these machines are being loaded with troops and taking them to Italy. As yet, no one seems to know what role these soldiers are to play in the spreading war.



How they do it in the movies. In the motion picture "I Wanted Wings," a crack-up of a North American BT-9 is depicted. Look closely at this shot and you'll see that the ship has no engine under its cowl. The fire was started by lighting lead-ropes soaked with some inflammable mixture.

DEBUNKING HITLER'S LUFTWAFFE

EVER SINCE I returned from France, the one question that seems to be asked most often is: "Which are better, the British pilots and planes or the German?" That one query has been put to me so many times that I've lost track of the number long ago. I've even got so that I recognize that certain light in a person's eye before the question is asked, and start to answer automatically.

That seems to be the subject everyone is interested in, more or less. And as this war, while it might not be definitely won or lost in the air, will at least have airpower as one of the deciding factors. I shall attempt in

Many articles have been written about the inferiority of the German Air Force, but those features were mostly speculation. Now, however, FLYING ACES presents the real, inside story!

by Lieutenant Thomas McBride

this article to answer many of the predominant queries.

In my opinion and judging from what I observed while abroad, the British pilots and planes are decidedly superior to the Nazi pilots and planes. In the first place, the British flyers are given a minimum of 250 hours primary and combat training,

by instructors who have had actual experience in combat units, before they are allowed to participate in any actual aerial warfare. Also, the British planes are built with quality as the keynote.

During the first stages of the War, this was a definite handicap due to the typical English stolidness and their bulldog tenacity in sticking to a fixed idea. It is a national trait that will, in my opinion, eventually win the War for them.

On the other hand, German policy is just the opposite. It remains to be seen which will prove the more effective in the long run. The young Nazi pilot has an average of 50 hours instruction before he is turned loose in a pursuit plane, which is just about the absolute minimum in which a man can learn to handle a 350 mile per hour ship. The mortality rate in the German training schools is naturally high, but the requests for entrance are so immeasurably greater that the loss factor is a minor consideration.

According to a German officer I spoke to during my short term as a prisoner of war, the Nazi's are working on the principle that due to mass production of both pilots and planes they can afford to lose approximately 4 to 1 and still stay even with the British. This advantage may have held true in the first stages of the War, but under the new British production methods it is doubtful if the same factors still apply.

One proof of the success of the British production method is the fact that before we went to France, Shorty Keough and I went up to Canada to enlist in the RCAF. (Editor's note: Mr. Keough has been reported missing, believed killed in action.) We were accepted at the recruiting station in Niagara Falls and naturally expected to go right to work. We hung around for three days at our own expense. Then, finally, we requested an audience with the officer in charge of the recruiting center and demanded to know when we would go on duty. We were horrified to discover that the average waiting time was three months, proof that England needed planes much more than she needed pilots. At the present time, however, aircraft production has speeded up so much that any pilot who can pass the examination and has the desire to do so will not only be accepted immediately but will be shipped out on the first boat to England and given a machine to fly as soon as he lands

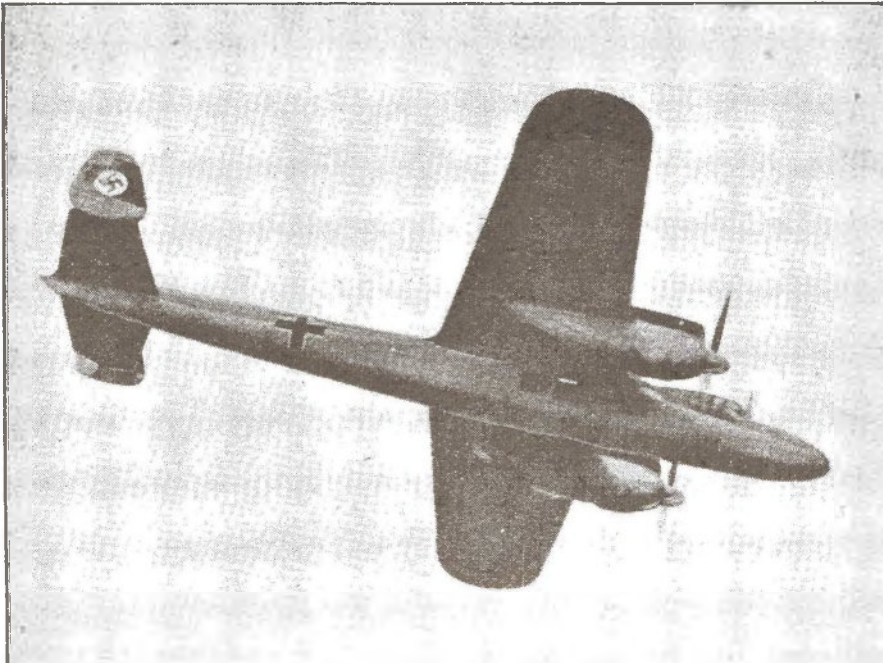

Above: The Dornier Do. 17 "Flying Pencil" is far under-gunned. RAF pilots have little difficulty maneuvering into a blind spot and picking them off. Below: "British airmen," says our author, "receive a total of 250 hours of instruction against the slight 50 given German air trainees."



on Britain's shores—this in spite of the fact that England's airplane losses exceed pilot losses almost two to one.

Another big advantage of the British method of training is that when the young Briton is graduated from Combat School he is assigned to that branch of the RAF in which he has shown the greatest adaptability. If, as in a great number of cases, he has shown more ability for the handling of big ships, navigation, and allied requisites demanded of a long-range bombardment pilot, he is assigned to bombardment. In the German Air School, however, because of the short time of the training period, they don't have ample opportunities to ascertain the peculiar abilities of each man. When he enters the School he is assigned to the type ship the Commanding Officer thinks he will be best adapted, and he is required to start and finish his training in that type machine. This cuts down the time required for experiment, but at the same time a lot of good pursuit pilot material is piloting bombers across the Channel in a job for which they are not temperamentally suited. And by the same token, many good bombardment pilots are out of place in cranky little fighters for which they have no real ability for handling.

FROM WHAT I have observed, nearly every major nation works on the principle that the best man to have in a fighter or interceptor is a young one. I know that I'm leaving myself wide open for beautiful arguments from some of the old timers who have on several occasions proved the superiority of experience over youth, namely in the Spanish War.

Automatically excluded are men of the caliber of Major Fred Lord, who is, in my opinion, and in the opinion of many, one of the greatest air fighters that ever lived.

The Nazi Air Force carries the young man idea to extremes, though. Practically every German airman with any pre-war experience was, at the outbreak of hostilities, immediately assigned to bomber outfits on the assumption that more experienced men were needed in that arm to handle the more expensive and more complicated multi-motored ships. The 17- and 18-year-old boys who joined the Nazi Air Force were sent to pursuit and interceptor units on the assumption that what they lacked in ability and experience would be made up by their recklessness in action. In peacetime, recklessness in an airplane is frowned upon by the powers that be, but wartime recklessness is a very decided asset in a fighter.

There are many cases of atrocities and murder of civilians that can be directly traced back to the extreme youth of the Nazi pursuit pilots. On many occasions I have heard of, and in more than one instance I have seen, the wanton machine gunning of civilian refugees by some Nazi pilot in a Messerschmitt. In some cases they have even carried this to extremes. In



Above: Bristol Blenheims are among the best machines in the RAF. They are not only medium bombers but also multi-place fighters and reconnaissance ships. Below: Many German craft are brought down because their pilots are not temperamentally fitted for the job given them.



one particular instance an American ambulance driver, Sam Pierce by name, was returning to the front to pick up a load of wounded. As he was driving along, the road in front of him suddenly erupted little spurts of dust. Being experienced in that sort of thing, Sam immediately recognized it for machine gun bullets. The road being right out in the open, he realized he didn't have a chance to run for it, so he jammed on his brakes and before the ambulance came to a stop he had dismounted and taken cover behind a boulder on the side of the road.

He gained the shelter of the boulder just as the German fighter reversed direction and headed back for another strafe. For more than 45 minutes, the Messerschmitt kept Pierce dodging in an attempt to keep the rock between himself and the plane. In the meantime, the Nazi pilot

filled the ambulance with holes. If there had been anyone inside, they would have been mincemeat when he finished. Finally, the young German, probably running low on gas, decided to head for home, but the killing fever had him in its grip so strongly that he turned around for one more shot at the boulder and the ambulance. And as he pulled up, he let fly with his machine guns at two cows grazing in a field nearby, killing both of them.

When this story was told to a German officer in Paris after the occupation, he said: "We are not beasts. But those young boys in the heat of battle lose their reasoning. It cannot be helped." Well, perhaps it can't be helped, but there must be something besides youth that makes them act that way. The British are young, too, yet even the Germans didn't accuse them of machine gunning ci-

vilians or grazing cattle.

While we're on the subject, one of the Nazi excuses for the murder of refugees was that a road is a military objective. Granted, any road is a military objective no matter how unimportant it is, but there can be no excuse made for machine gunning a column of refugees when there is not a military car or conveyance of any sort within sight. Machine gun bullets do not make a road unfit for military use as bombs do.

Another thing: The machine gunning of ambulances. During the first months of the War, all ambulances were painted white. Then the Allies realized that instead of protecting them they just attracted attention, so they painted them a dull O.D. color and marked them with a big red cross on both sides and on the top. They later found that the cross on the roof was being used as a target by the Nazi ships. Finally, for their own protection, they painted out the cross, colored the ambulance the typical green and brown camouflage, and took their chances with army transports, realizing that it was safer that way.

So much for the tactics and comparative abilities of the British and German pilots. Now let us turn to the planes. In bombardment types, the old question arises: Which is better, quality or quantity? The Germans at present have quantity and the British have quality. It is not meant to infer that the German bombers have a habit of falling apart in the air or any such extreme. When I say that the British have superior machines, I mean that they are better engineered, have better materials and instruments, and have a longer operating life with fewer breakdowns and need less care.

AND NOW the question uppermost in everyone's mind. Which is the better fighter, Spitfire, Hurricane, Messerschmitt or Heinkel?

Well, let's take them apart and see. First, we will match them as to type. The Spitfire and Heinkel come under the heading of interceptors and therefore are not really fighters. They are used mostly against bombers over home territory. I don't know of any case where a Heinkel interceptor has been shot down over England, and the ship is still more or less of a mystery except for rumors. One of the most persistent rumors, however, is that the Heinkel has acquired the reputation of being a pilot killer. It is evidently so overpowered and so lightly built, to obtain the maximum speed and rate of climb, that it has turned into a tricky, un dependable, and unmanageable ship. To bear out this rumor is the fact that the British bomber pilots on sorties over Germany report being attacked by Messerschmitts quite

often, but very seldom do they see any Heinkels.

Although the Spitfire cannot maneuver with the Hurricane, it can and has given a good account of itself against Messerschmitts in the defense of England although it was not designed with that purpose in mind, being primarily for use against bombers. It has a rate of climb of more than 5,000 feet per minute, and although some maneuverability was sacrificed for speed and climbing ability the British again seem to have struck the happy medium.

And now the German Messerschmitt 109 and the British Hurricane: According to the German Air Force chiefs, the Me. 109 was the second fastest plane in the world, the Heinkel being the fastest. But in spite of all its publicity, it has turned out to be just another fighter with both

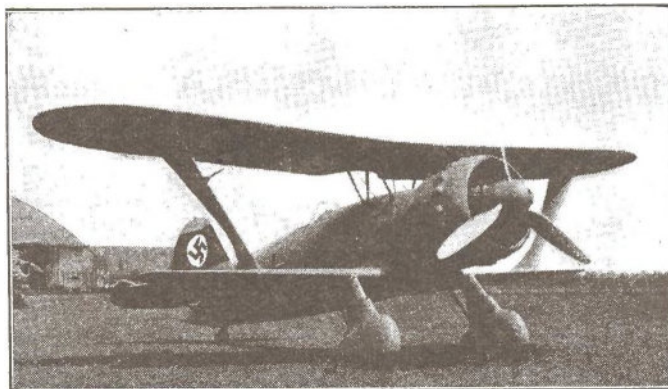

According to Lieut. McBride, the Henschel Hs. 123 is not a bad ship. However it is admitted that it is too slow and has weak fire-power.

its good points and its bad points.

The main good points are its speed and ceiling. It was the consensus in France that the Me. 109 had a slight edge on the Hurricane in those respects. Here again the old German habit of sacrificing everything for superiority in particular traits crops up. The clipped wings on the Me. 109 cut down its maneuverability to such an extent as to give the Hurricane that extra advantage which is all that is needed to spell the difference between victory and defeat. Here again the British seem to have split the difference. The Hurricane is plenty fast, being able to clip along at nearly 400 miles per hour, and yet it is much more easily and quickly handled in a dogfight.

I have spoken to several RAF men from the Advanced Air Striking Force in France, and their opinion was that all other things being equal there were three ships that could lick a Me. 109 every time, the three being the Hurricane, the Curtiss Hawk 75, and the Westland Lysander. It surprised me to hear the Westland Lysander mentioned in the same breath as the Hurricane and Hawk since the Lysander is a two-place high-wing Army Cooperation monoplane that was not intended for combat work. They assured me that it was not a slip of the tongue but that

it was an actual fact that the Lysanders were hanging up an enviable record against Me. 109's. It seems that the Lysander is capable of an extremely tight turn, and when attacked by a Me. 109 it would immediately go into a vertical. And as the Nazi went by, the Lysander would come out of the vertical and be on the Me.'s tail.

If by this time the Me. was still going strong, the Lysander would hit for the carpet and go hedge-hopping home between the trees. The 109 wouldn't dare go down as low as a Lysander, and would usually give up in disgust.

The Hurricane, as has been said before, is more maneuverable than the Me. That statement also applies to the Curtiss Hawk. The Hawk and Hurricane are about equal in this respect but the Hawk has a little trick up its sleeve discovered by the French in the early days of the War.

A French pilot flying a Hawk one day found a Me. 109 on his tail. He tried every trick in the book to escape and finally wound up doing a series of dives and zooms in quick succession with the Nazi right on his tail.

Finally, the Frenchman, almost ready to give up, came out of the bottom of a dive and, pulling into a quick zoom, cut his throttle all the way. The big radial engine front acted like a brake, cutting the plane's speed instantly by about 100 miles per hour.

The Nazi, quick on the trigger, cut his throttle also, but since the streamlined nose of the Me. 109 offered no resistance the Nazi machine went right on past the Hawk and was cold meat for the Frenchman. As soon as the story was told back at the airdrome, everyone flying a Hawk tried the same tactics. The Nazis never did get wise to it, and they were still being taken in by the same trick up until the time I left France to return to America. This maneuver—if it can be called that—cannot be utilized by the British, however, because of the fact that RAF first-line fighters are all powered with streamlined liquid-cooled power plants. Now, above England, it's superior fire-power that knocks down German combat craft.

To completely boil down this pro and con discussion, the real reason for the British superiority is that their pilots are trained better and their planes are built for service flying and not merely for war. This, of course, means that they are constructed of the best materials and only very close tolerances are allowed. Don't for a moment, however, think that the Germans are anything near "cold meat." They fly like demons, shoot like devils, and have the courage of real fighting men.

THE END

Squadron Leader O. R. Gayford and Flight Lieutenant G. E. Nicholletts back in July, 1933, set a long-distance non-stop record with this Fairey Napier. They flew 5,340 miles in 57 hours and 25 minutes.

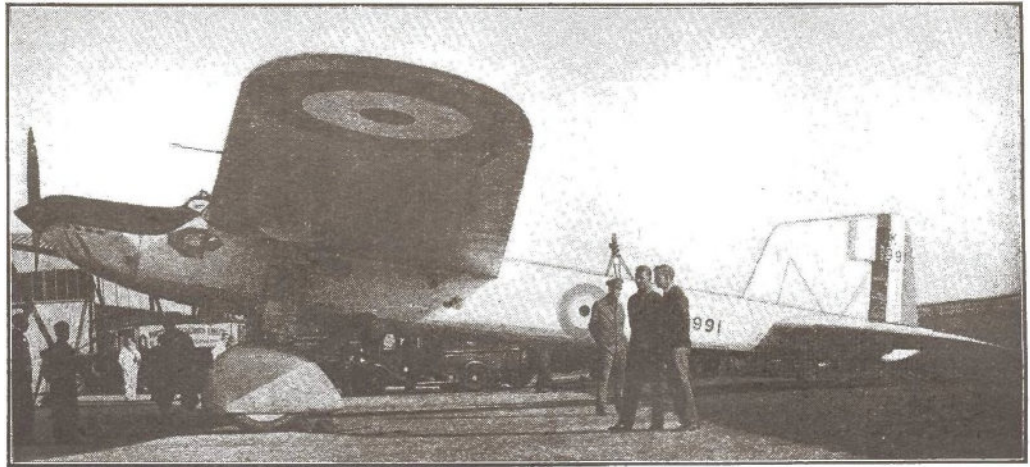

Below: Curtiss Hawk P-3A's were first-line Air Corps pursuits in 1928. This craft was fabric covered, mounted two .30 caliber machine guns and was powered by a Pratt & Whitney Wasp engine.



Lucian Moebus wishes Lieutenant Ben Mendez happy landings just before the latter took-off for a good will hop to his native Colombia. His plane was an early Vought fitted with a Wright engine of 200 h.p. The chap on the left is Mendez' mechanic, John A. Todhunter.



DOWN MEMORY'S RUNWAY

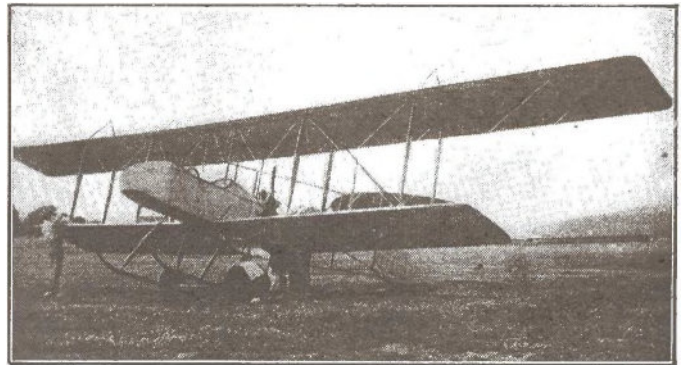

One of the strangest appearing war planes to see service with the Allies during the First World War was the Vickers Gun Bus. It had a crew of two and was powered with a 100-h.p. Monosoupape rotary engine set in pusher style. Top speed was rated at about 90 m.p.h.

Here's an old-time racer we'll wager you've never seen. It's the Curtiss Texas Kitten of 1922 vintage. Power was supplied by a Liberty liquid-cooled engine of 400 h.p. Note gull wing and huge prop spinner. Fuselage construction was monocoque; cockpit was open.

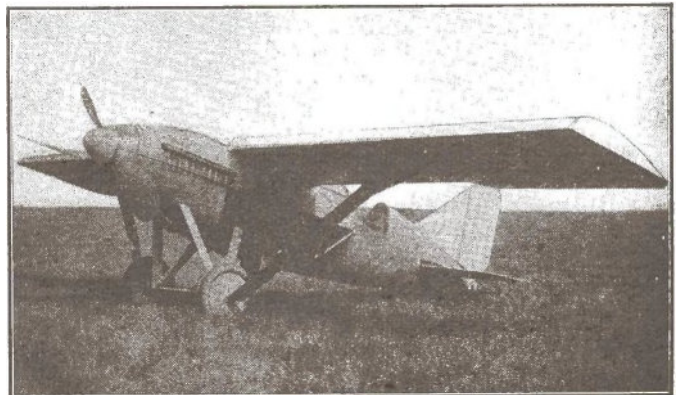

Raider Wings in the Pacific

CHAPTER I

MYSTERY MUSIC

THERE WAS a sudden hush in the airline office. Above the pounding of the surf Dick Knight thought he heard a faint humming, but it stopped before he could be sure. His black goggle-type glasses completely hid the room from him, but he heard Lothario Doyle, his secret-agent partner, give a muttered exclamation. Captain Weldon, the naval governor of Guam, had abruptly ceased talking.

"What happened?" Knight asked.

"The lights turned a strange color for a moment, a sort of greenish-purple," answered Weldon. "The effect was downright ghastly, coming so suddenly."

"It sure gave me the creeps," grunted Doyle. "You and Dick looked like a couple of stiffs sittin' there."

Knight caught the peculiar note in Doyle's voice. It wasn't like that tough ex-Leatherneck to be disturbed over a mere incident of erratic lights.

"I'd like to have seen that. But there was something else." He stood up, felt for the door with a practiced hand. "I heard an odd humming, and it might have come from outside."

"What good could you do?" Weldon said irritably. "If you'll pardon my bluntness, Naval Intelligence got its wires crossed, sending a blind man out here."

Knight smiled to himself as they stepped out into the darkness. Ever since an injury to the optic nerve had

made his eyes super-sensitive, he had been forced to shield them from light. Doyle and he had reached Guam by Clipper only that afternoon, and the governor had arrived from his palace but a few minutes ago. There had been no time to explain.

"There's no one lurking out here," Weldon said curtly. "Even if some one had been humming, what would that have to do with lights?"

"Perhaps I imagined it." Knight lifted the black glasses as Weldon peered down at the Clipper station where the ruins of a hangar bore testimony to a recent typhoon. To his oddly sensitive eyes, the darkness immediately dissolved into a clear gray light. Ten miles across the shallow

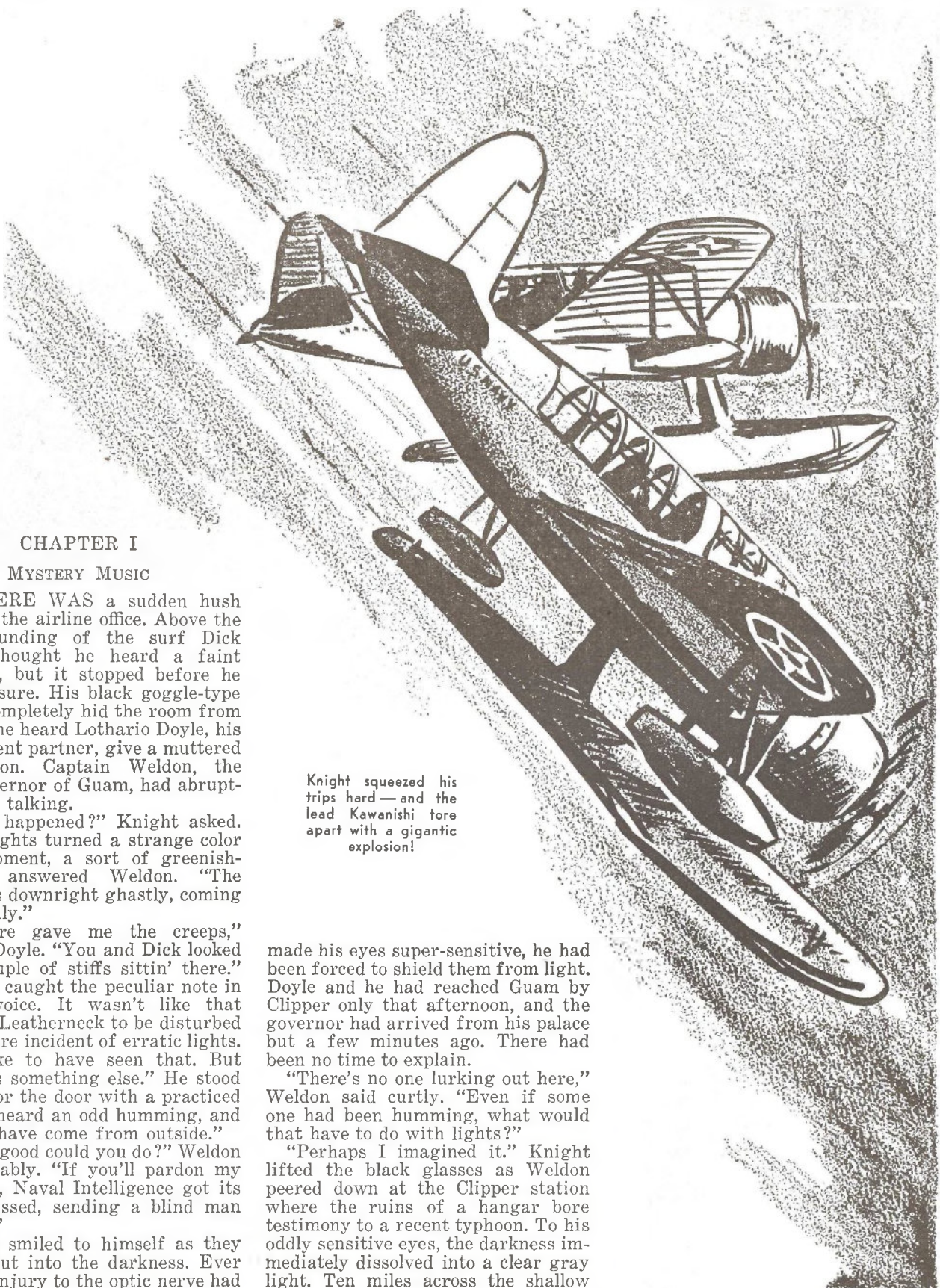

Knight squeezed his trips hard — and the lead Kawanishi tore apart with a gigantic explosion!

"Tainen—all mine!" That mad message blasted from nowhere as Richard Knight and Lothario Doyle sat in the governor's office at Guam. And then an insane cry of agony came through space! That was puzzling—but the face that then came from the grave was even more startling!

by Donald E. Keyhoe

Illustrated by Ed Smalle

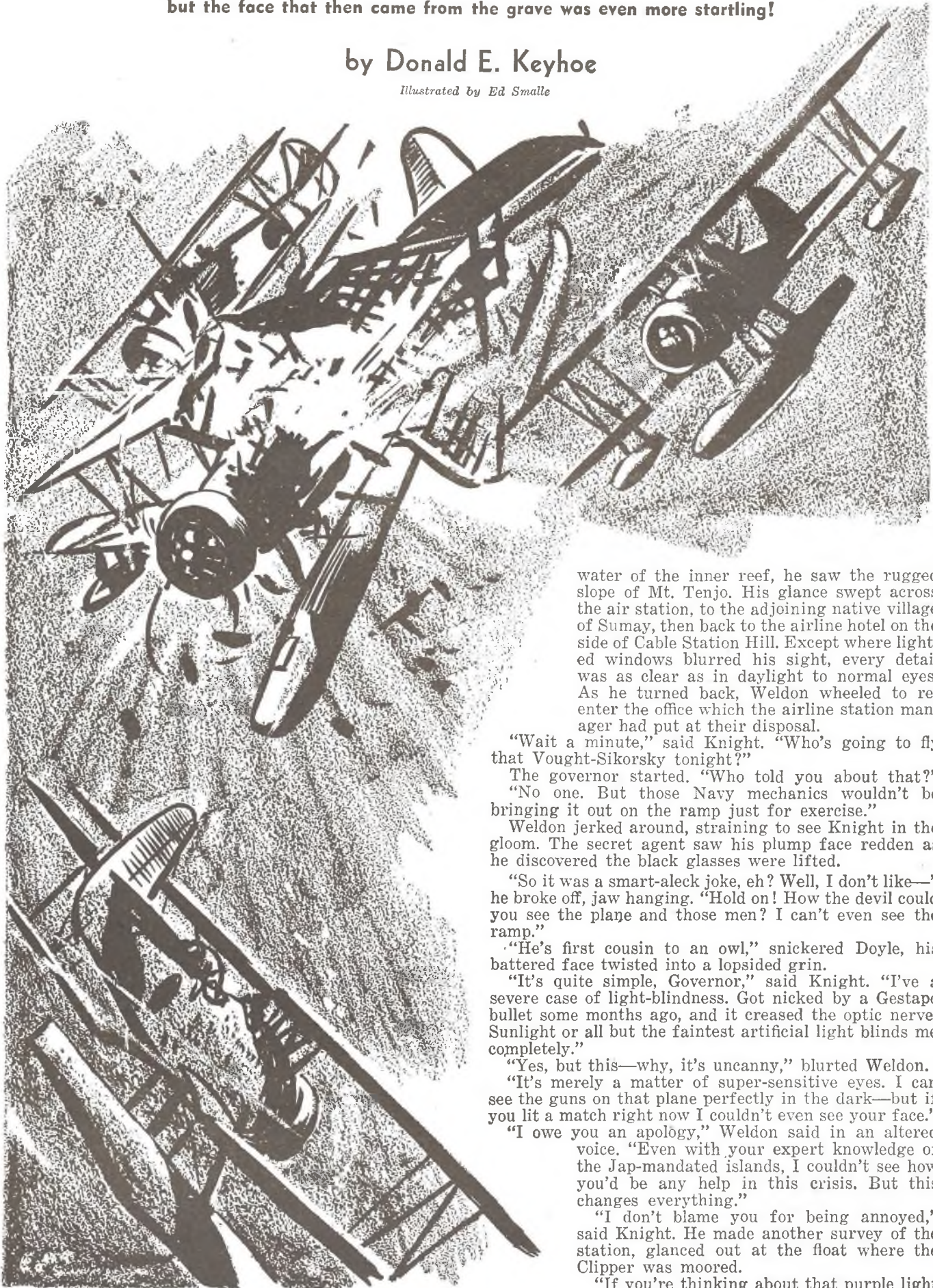

water of the inner reef, he saw the rugged slope of Mt. Tenjo. His glance swept across the air station, to the adjoining native village of Sumay, then back to the airline hotel on the side of Cable Station Hill. Except where lighted windows blurred his sight, every detail was as clear as in daylight to normal eyes. As he turned back, Weldon wheeled to re-enter the office which the airline station manager had put at their disposal.

"Wait a minute," said Knight. "Who's going to fly that Vought-Sikorsky tonight?"

The governor started. "Who told you about that?"

"No one. But those Navy mechanics wouldn't be bringing it out on the ramp just for exercise."

Weldon jerked around, straining to see Knight in the gloom. The secret agent saw his plump face redden as he discovered the black glasses were lifted.

"So it was a smart-aleck joke, eh? Well, I don't like—" he broke off, jaw hanging. "Hold on! How the devil could you see the plane and those men? I can't even see the ramp."

"He's first cousin to an owl," snickered Doyle, his battered face twisted into a lopsided grin.

"It's quite simple, Governor," said Knight. "I've a severe case of light-blindness. Got nicked by a Gestapo bullet some months ago, and it creased the optic nerve. Sunlight or all but the faintest artificial light blinds me completely."

"Yes, but this—why, it's uncanny," blurted Weldon.

"It's merely a matter of super-sensitive eyes. I can see the guns on that plane perfectly in the dark—but if you lit a match right now I couldn't even see your face."

"I owe you an apology," Weldon said in an altered voice. "Even with your expert knowledge of the Jap-mandated islands, I couldn't see how you'd be any help in this crisis. But this changes everything."

"I don't blame you for being annoyed," said Knight. He made another survey of the station, glanced out at the float where the Clipper was moored.

"If you're thinking about that purple light

business, forget it," Weldon spoke up. "Probably something went wrong with the dynamo. I've something important to tell you—a secret that Tokio would give a fortune to know."

Knight drew the black glasses over his eyes as they went back into the lighted office. He heard Weldon close the door.

"You may have guessed part of it, seeing that plane on the ramp," Weldon said in a lowered tone. "But as I understood from my code instructions, you men left the States without any knowledge of your mission."

"Just orders to report to you," said Knight. "But I've a hunch it's hooked up with the Jap threat to attack British bases and ships in the Far East."

"It's a lot worse than that. We're sitting on a powder-keg, and inside of forty-eight hours it may—"

"The lights!" yelled Doyle. "There they go again!"

IN THE same instant, Knight heard the eerie humming. It changed swiftly to a swelling harmony of muffled, bell-like notes. There was something weirdly beautiful about it, yet a minor harmonic that ran through it sent a shiver down his spine. He snatched off the black glasses and sprang to the door. Then he spun around, for the strange music came from within the room.

A pale greenish-purple light was streaming down from the fixtures overhead. His eyes saw it only as a swimming blur. Weldon and Doyle were gaping up at the lights, their faces a sickening color. And then Knight realized that the mysterious music came from inside the electric bulbs.

The ghastly luminance faded still more, then suddenly the bulbs grew brighter. Through the weird harmony came a hissing sound, a sound that grew into a whispering voice.

"Death at Tainen . . . Keep away . . . Tainen all mine—"

The whisper broke off with a wild cry. It was impossible to tell whether it was mad laughter or some even more frightful emotion, for it was drowned almost at once with a thundering chord of music. The lights flared, went out, and in the darkness Knight saw his companions stumbling toward the door.

"Did you hear it?" Weldon said hoarsely. "Did you hear that voice?"

"I heard it," Knight said grimly. "And judging from the row outside, so did every one else."

The door burst open and a white-clad figure halted uncertainly in the gloom.

"Governor Weldon! Are you in here?"

"Hall!" exclaimed Weldon. "You heard it, too—that voice and the music?"

"I didn't get everything the voice

said." The station manager looked tensely over his shoulder. "Our lights burned out and the native houseboys made such a racket stampeding out of the hotel. But that isn't why I came. I had our radioman listening in on that frequency, as you asked. We'd switched the beam to guide the plane in, but just a few seconds before that ghost-music started we caught an emergency flash from Miller."

"Miller! What was it—quick?"

"All we got were three words, 'Am being attacked.' It was in code, with Miller's number, 3-M, at the start. When that music began, everything went dead."

"You mean that stuff came in on the radio, too?" demanded Knight.

"No, but it killed the signals. We tried all over the dial and couldn't pick up a thing."

"Who is Miller? Where's he coming from?" Knight fired at the governor.

"He's a Navy two-striper flying as a special courier from one of our cruisers. He was going to lead you and Doyle back to—"

"Listen!" Knight said sharply. Barely perceptible, the drone of engines sounded from somewhere over the dark sea. "That must be Miller. Is that ship on the ramp ready to go?"

"It's all set," Hall said as Knight went past him. "The crew-chief reported just before all this happened."

"Come on, Lothario!" Knight ran down the path with Doyle and the others behind him. As he neared the seaplane he shouted for the crew to start the engine, and the prop was whirling when he reached the cockpit.

"Keep the lights off down here," Knight hurriedly told Hall. He climbed into the front pit, cranked the enclosure shut, after a signal to the crew chief.

"We'll warm the engine taxiing out," he shouted back to Doyle as the dolly slid down the ramp. The seaplane rode free,

roared ahead through the channel. Knight fastened his chute and belt, plugged in the intercom.

"There's one sweet scrap goin' on up there!" Doyle's voice boomed through the phone. "Can you see what's what?"

Knight flicked a glance skyward as he let the ship swing into the wind. "They're in the edge of the clouds—one looks like a Kawanishi—can't be sure."

HE GUNNED the engine and the scout-bomber quickly came up on the step. He lifted it into a climbing turn, switched on the gun-circuit. Above, tracers from the battling planes made blurred streaks that in-

termittently reduced his dark-vision. Apparently the pilots were fighting with only the tracer-lines to guide them, for no flares had been released.

The two-seater was almost at 3000 feet when the fighting ships suddenly broke away from the clouds. Knight saw a Kawanishi 95 seaplane with the rising sun insignia of Japan plunge down steeply. For an instant he thought it was an attack, then he saw another Vought-Sikorsky on the tail of the Nipponese ship. The observer had toppled over his gun and the pilot was frantically twisting from side to side in his dive. Behind the Vought-Sikorsky, three more Kawanishis hurtled down with guns flaming.

Knight whipped into a tight chandelle, flung a burst at the first of the trio. The pilot's head jerked around and Knight saw the amazement on his brown face at this new addition to the battle. The Kawanishi pulled out and the two ships behind it hastily spread.

Doyle's guns clattered and the two Jap ships swiftly converged on the source of the tracers. Knight rolled into a vertical bank, caught the nearer Kawanishi in his sights. The Brownings drilled slantwise across the rising-sun emblem, dropped the gunner in a limp heap. The pilot zoomed wildly, flew straight into Knight's second burst. The Jap plane slued onto its left wing, then the N-strut collapsed and the whole wing went to pieces. The wrecked ship plummeted toward the sea.

As Knight twisted back he saw the other Vought-Sikorsky. The pilot had finished off the Kawanishi that had dived away from him, but the two remaining Jap ships were darting in on his tail. Tiny jets of fire were stabbing back from the nose of the Navy plane and Knight saw the pilot go into a steep sideslip to drop away from the flames.

Half-blinded by the glare, he tripped his guns and dived at one Kawanishi. The flames brightened, blotted out his vision.

"Grab the controls! Hold it dead on!" he shouted into the intercom mike. "I'll keep firing!"

Doyle's answer was lost in the roar of the guns. Knight held the stick-button down a moment longer, then the scout-bomber gave a violent lurch. He felt a hail of slugs drive against the cowl, and air blasted in through a gash in the Plexiglas. Doyle groaned.

"Lothario!" Knight said tautly. "Are you hurt?"

"No—but they got Miller. He spun in near the channel."

Knight's vision came back quickly. He flung a swift look downward. The wrecked Vought-Sikorsky lay in shallow water on the inner reef at the southeast end of Apra Harbor. The flames were out and he could see a rescue crew jumping into a boat at the dock. With a grim face, he took the controls, went after the two Kawanishis as they zoomed up from their victory.



WINGS SCREAMING, the scout-bomber dropped on the first Jap ship. Knight flicked a lightning glance at the ammunition counter. There was barely enough left for a half-second burst. His thumb settled closer to the stick-button. The Kawanishi leaped up under his guns and he jammed his thumb down hard. One brief flash from the Brownings and the Nipponese seaplane went hurtling down into the sea with its tail shot off.

When Knight pulled out of his dive the other Kawanishi was racing northward, climbing at full speed for the clouds. He closed the throttle, landed near the channel. The rescue-boat was already speeding back to the dock. He followed, taxiing gingerly through the narrow passage to the ramp, where mechanics pulled the scout-bomber onto the dolly and hauled it out of the water.

As he switched off the engine and climbed out he saw Captain Weldon and a Navy doctor bending over a stretcher. A hospital corps man was trying to stop the flow of blood from Miller's wounds. The wounded pilot slowly opened his eyes and the ghost of a smile touched his ashen face.

"No . . . use," he whispered. "All gone . . . inside."

His eyes closed again, but Knight saw he was still breathing. Then one of the airline men hurried up with an emergency light at the end of a cable, and he had to put on the black glasses to shield his eyes.

A faint, weird harmony became audible, and Knight reached out, felt for Doyle's arm.

"Where's that from—the emergency-light bulb?"

"Yeah," muttered Doyle. "And it's that same color, too, but brighter."

"Miller," Weldon's voice came through the darkness surrounding Knight. "Miller—can you hear me? What happened? Where's the fleet?"

There was an interval with only the strange, muffled music. Then Knight heard Miller's labored words.

"Enemy . . . contacted . . . New ships . . . didn't see till after . . . catapult."

The pilot's voice trailed off into a moan.

"New ships?" said Weldon anxiously. "You mean the rumor was true?"

"Not sure . . . couldn't tell . . . silhouettes," whispered Miller.

"Where?" the governor's voice came again, with a mounting anxiety. "Where was the fleet when you took off?"

"Position . . . on map." Another moan stopped the dying man and Knight could barely hear the rest. "Orders to rejoin . . . off Tainen . . . bring Knight and Doy—" Miller's voice faded into silence and Knight knew it was the end. In the hush that followed, the muffled notes of that music from nowhere were like a requiem for the dead. The hospital corps man bent down quickly, felt Miller's pulse. He straightened, shook his head sadly.

Know America's Planes

NUMBER THREE

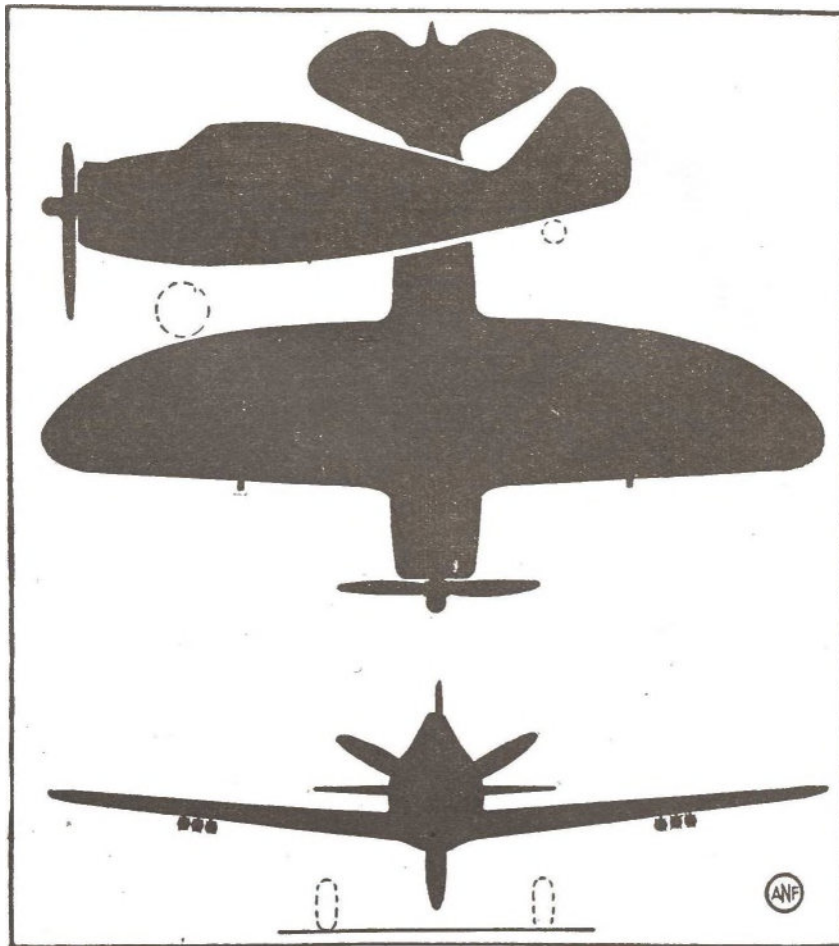

THE AMERICAN aircraft industry's ability to produce every type of plane needed for defense is illustrated by the Republic Lancer. Designated by the U. S. Army Air Corps as the P-43. A high altitude fighter, the P-43 is designed to attack bombers at heights above 25,000 feet and has a supercharged engine with a secret Republic installation to give it unexcelled efficiency in the stratosphere.

This plane is really nothing more than a variation of the old Seversky P-35 which was ordered by the Air Corps some years ago. The general fuselage lines are the same and the wing plan is the same. The

only noticeable changes are the use of an inward folding retractable undercarriage and a slightly different cowl design.

The Farmingdale, N. Y., plant where the Lancers are manufactured, it might be well to mention, is being made larger to make for faster production facilities. At the present time, three main buildings are used by Republic—one for assembly, one for metal work, and one for painting. The metal shop until a few years ago was the Grumman factory, before they moved to Bethpage, L. I., into new quarters. In addition to these three buildings, the hangar is used for assembly of export planes.

CHAPTER II

ZONE OF SILENCE

"TAKE THAT blasted light away," Weldon said in a husky voice. "It's bad enough seeing the poor fellow die, without that light—and that infernal music."

Knight heard the swish of the cable on the ramp. He lifted the black glasses as darkness fell over the scene.

"Here's the map, sir," said a me-

chanic. He handed the dripping sheet to Weldon. "I found it in the cockpit."

"You're certain Miller was alone?" asked the governor.

"Positive, captain. And the seat-belt in the rear was secured, so it couldn't have been a case of the gunner falling out."

Knight bent to look at the map in Weldon's hand.

"From the position marked," he said in an undertone, "he had a long

(Continued on page 58)

Modern Planes Album

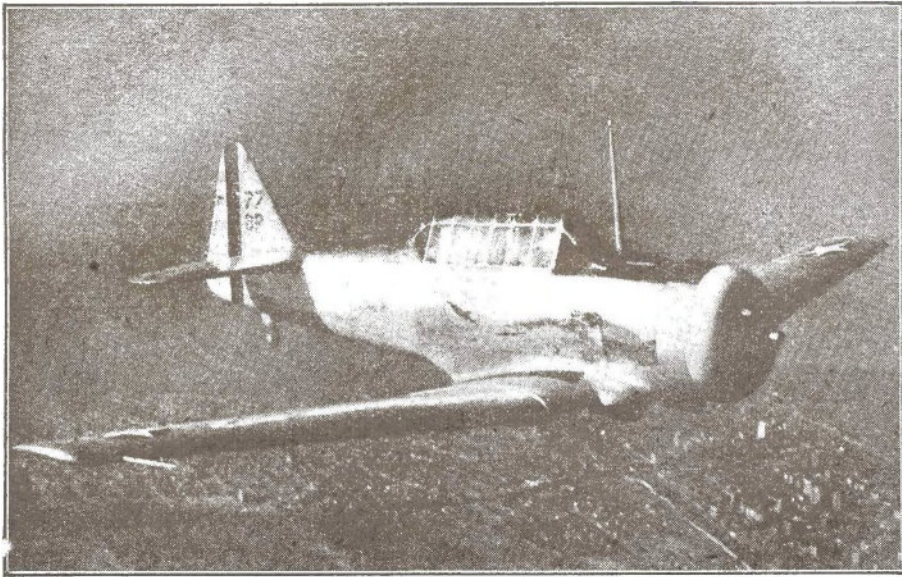

NORTH AMERICAN AT-6

NO ONE can belittle the importance of the instruction machine today and it is interesting to watch the progress of trainers both here and abroad. It has been said that the superiority of British airmen has been due mainly to the step-by-step advances they are able to make be-

cause of the splendid training craft they have available. To start with steady and reliable Moths and go through the course to the Miles Master, produces a pilot who should be able to fly anything.

It is to be hoped that we in this country are learning the lesson the British are teaching us.

Here is a new type listed as the North American AT-6 which is now being used, according to factory publicity, in large numbers by the No. 36 Pursuit-Interceptor Squadron now stationed at Mitchell Field, Long Island. It is a dual-control ship powered with a 450-h.p. Pratt & Whitney radial. It has a cruising speed of 160 m.p.h. and an operating range of 1,000 miles.

The cockpit is most adaptable for the work as it provides a seat that has all the normal controls and another which offers blind-flying cover and suitable blind-flying instruments. In this way, then, two trained pilots may go aloft at the same time and check each other and get much needed experience.

All this, of course, adds up to the fact that at last our Pursuit-Interceptor squadrons are going in for night-flying. In the past, our fighters were daylight outfits which were not fit for night duty. The experience of the British and Germans in their attempts to stop night raiding has brought out this problem in greater relief and it is about time that something was done about teaching our pursuit stars just what this night-flying business is all about.

NORTH AMERICAN NA-50
THE North American NA-50 is a new single-seater fighter designed for U.S. export markets. We presented details on this machine some time ago, but as there have been several changes made and since we have since received further details on the craft, we feel that we should offer it again.

The NA-50 is powered with a Wright Cyclone GR-1820-G203 engine and has a top speed of 295 m.p.h. at its best operating altitude of 9,500 feet. It cruises at 255 m.p.h. at 16,000 feet, lands at 70 (with the flaps down) and has a normal range of about 1,038 miles. It is said to climb to 10,000 feet in three minutes.

The NA-50 is a low-wing cantilever monoplane with the wing constructed in five sections. It has a two-spar center section, two removable single-spar outer sections, and two detachable wing tips. The spars and ribs are composed of aluminum-alloy and the wings are covered with stressed-skin. The flaps and ailerons are metal frames covered with fabric.

The fuselage is all-metal. The forward portion is built up of chrome-molybdenum steel tubing and has metal side panels. The rear portion has a semi-monocoque construction

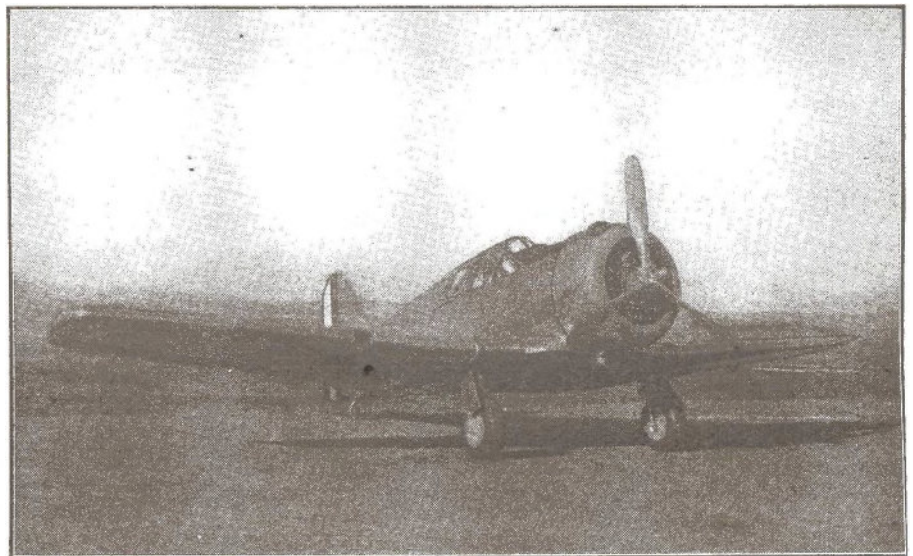

NORTH AMERICAN NA-50

with suitable inspection doors. The undercarriage is a retractable type using the single-leg half-fork fitted into air-oil shock absorbers. They fold up inwardly and are fitted with hydraulically-operated differential brakes and a parking brake. There are two fuel tanks in the wings carrying 170 gallons of gasoline. The motor is fitted with a three-bladed

constant-speed airscrew.

The armament includes outer wing mountings to carry various types of small bombs. Only two machine guns are fitted. The pilot's cockpit is covered with Plexiglas hatches and there are shatterproof glass windows at the sides.

This would be a useful machine if it were better armed.

FAIRCHILD PT-19

ANOTHER trainer story comes out with reference to this new Fairchild PT-19 which we have presented before. We have been informed now that one thousand of these machines have been ordered for national defense training, that they are being delivered at the rate of two a day, and that more than 200 have already been delivered.

One wonders what will happen to them all when the defense plan is through and the world settles down again to a normal existence.

The Fairchild PT-19—which means Primary Trainer-19th type—is a low-wing monoplane powered with the 165 Ranger engine and has a special fixed type undercarriage. While the ship is listed in the primary training category it is obvious that anyone able to fly a 165 h.p. job that can cruise at something like 125 m.p.h. is hardly a novice. With a few important hours on such a plane one would soon be ready for any of the advanced trainers the Army has to offer.

The ship is a low-wing monoplane with a fabric covered fuselage and metal faced wing panels. The body structure is welded tubing. Both cockpits are shielded by three-sided windscreens and a truss-type crash-protector is located between the pits to take the shock in case of accidental student landing turn-overs. The wing

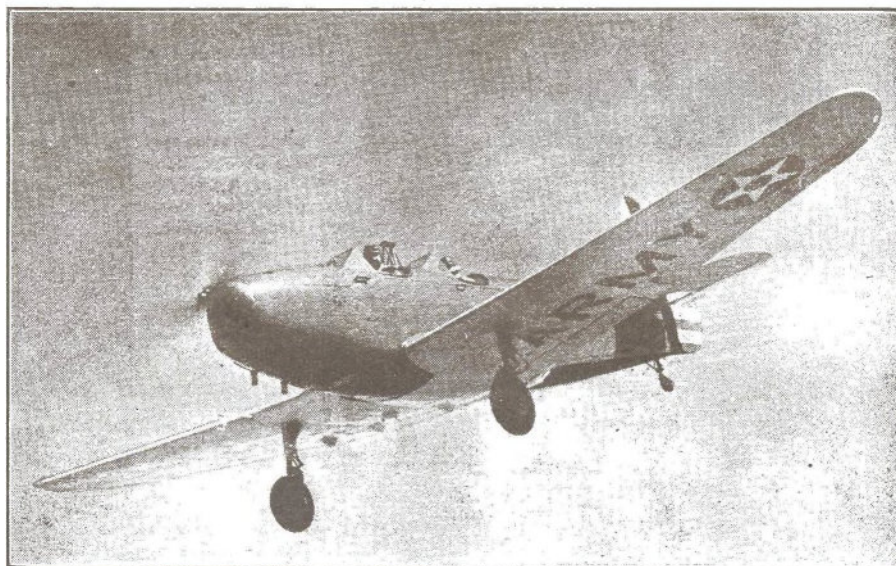

FAIRCHILD PT-19

is constructed in three sections, with the center panel integral with the fuselage.

The Ranger engine is a six-cylinder in-line inverted air-cooled plant manufactured by the Ranger Engineering Corporation of Farmingdale, L. I. This inverted type often intrigues many who have never been shown such a power plant. For one thing, they cannot understand how such a motor can be lubricated.

In the case of the Ranger, the entire engine is pressure- or flood-lubricated. It has separate pressure

and scavenger oil pumps. The pressure pump is located in the rear of the crankcase and the double-scavenger pump is in the rear of the crankcase housing. This pump is fitted to scavenge oil from the front and the rear of the housing. The relief oil is thus carried back to the tank. The pressure system to main bearings and pistons is carried by pressure through the crankshaft and is so arranged that stoppage at one point will not affect proper lubrication of all main and connecting rod bearings.



CANADIAN GREGOR FDB-1

CANADIAN GREGOR FDB-1

CONSIDERING how many Canadians served in the RAF of the other war, it is strange that few if any have been identified with the design and development of any outstanding aircraft, whether it be military or commercial. Canadians were natural airmen and still are from all accounts, but we find it difficult to

discover one who has given anything in the matter of design or development of fighting aircraft.

In the past few months we have heard something about the Canadian Gregor fighter. This machine was designed by a Canadian, one Michael Gregor who is connected with the Canadian Car and Foundry Company of Fort William, Ontario. The com-

pany is also making a radial engine rated at about 200 h.p. which will be known as the Maple Leaf. Further, they have manufacturing licenses on several of the Grumman types and build component parts for the Hampden, Sterling, Avro Anson, Hurricane, and Bristol Bolinbroke.

The Gregor, now listed as the FDB-1, was originally designed by Gregor who once served with the RAF. It is a biplane fighter powered with a 750 h.p. Wasp engine and appears to have many of the lines of the Grumman fighter.

It is a stubby job and should be more maneuverable than the average monoplane because of the shortness of the wingspan. However, we have no record of its being in any way acceptable to either the Canadian or British authorities. It will be noticed that while the plane has been designed for military duties it carries Canadian commercial markings and has not as yet been honored with RAF insignia.

The retractable undercarriage folds away into wells high in the main portion of the fuselage beneath the upper wing. The single cockpit is covered with Perspex hatch coverings.



Left: The medical examiner uses a hand slit lamp and binocular magnifying glasses while looking for eye defects. Poor vision is responsible for many Cadet rejections.



Right: Another eye test is carried out with a green refractor. This machine is used for testing muscle balance and range of vision. This examination is of utmost importance for flying.

PASS THE PHYSICAL

AMERICA'S youth looks skyward and from their ranks are selected the future knights of the air. Pilots, by and large, are magnificent human material. They are expert, daring, and must possess the highest possible morale if they are to be more than "just average."

The examinations of candidates for military aviation are now the most exacting in any branch of the Army or Navy service. The reasons for the high physical standards are obvious because high speed combat planes and aerial warfare have imposed new and serious health problems.

The stress of military flying is so severe that only boys and young men can pass the physical standards. In quick turns, dives, and battle maneuvers at breakneck speed, older men blackout for several seconds more than younger men. It is a simple question of physical stamina.

The flying fitness tests for military pilots are now well standardized. A general physical survey and medical history is first taken. This includes an inquiry into current infections, recent illness, and operations. The applicant for flight training must come within 16 pounds of normal weight for his age and height, he must not weigh over 200 pounds, and he should not be more than 74 inches nor less than 64 inches tall.

If the candidate passes the general survey he next undergoes special examinations by the flight surgeon. First, he receives the usual tests for nearsightedness, farsightedness, and astigmatism. Passing these, he is tested for the eye's ability to appreciate form. This is done with the Snellen test letters which one sees in

There's a lot more to becoming an Army or Navy pilot than just having the required schooling. Many more prospective flyers are grounded in the doctor's office than on the field or in the air.

by Captain Joseph G. Levine

Flight Surgeon, Medical Reserve

Photos from U. S. Air Corps, Randolph Field

every doctor's office. If the applicant can read the next to the bottom line of letters at 20 feet, his vision is rated 20/20. If he reads the last line his vision is 20/15, which is the usual observation.

The depth perception test, or the ability to determine the third dimension, comes next. A lighted box, casting no shadows on the inside, is set 20 feet in front of the candidate. In the box are two upright black rods, one of which is movable, and cords are attached to them. The examinee must line up the rods by tugging at one of the cords. If he sets them up within one inch of each other in a series of five trials, he passes. This test has been found of practical importance in the judgment of distance in landing.

The eyes are next tested for muscle imbalance with phorometer and Maddox rods. This is done by lining up streaks and spots of light, with the examiner noting any deviation from normal. It is followed by the tangent curtain and nystagmus tests that determine whether the muscles moving the eyeballs are normal. If the muscles are either under or over active, the candidate is rejected. The eyes are tested for color blindness with

color plates and colored bits of yarn.

The test for night blindness follows. A deficiency of vitamin "A," or a faulty diet, may be responsible.

The candidate stares at a special light for three minutes to bleach or dazzle his eyes. The exhaustion of the retina causes inability to see clearly at night, and the applicant's ability to recuperate this loss determines his fitness. Many motorists who drive at night are familiar with this visual disturbance.

After the "bleaching," all lights save one of low luminosity are extinguished. The examinee then watches for the time when he can first perceive it. He passes the test if he can describe the light correctly within three minutes.

THE CANDIDATE'S heart and circulatory system must be in excellent condition. He is given an intensive cardiovascular examination, including the electrocardiogram, blood count, and hemoglobin estimation.

The ear, nose, and throat examination is particularly exacting. At first, prospective pilots were whirled around on a stool for the equilibrium test, and if they became intensely dizzy and sick they were rejected.



Left: The candidate for flight training undergoes many different exercise tests during his physical. The medical examiner holds a stop-watch, timing the examinee for his reactions.

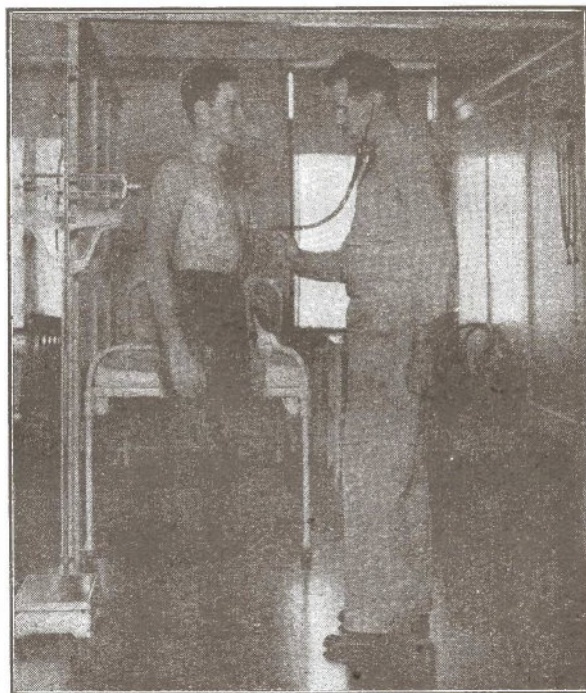

Right: U.S. Air Corps pilots must be perfect physically to perform their duties properly at all times. The stethoscope in most cases will reveal any defects of the heart, lungs, or stomach.

AND FLY

Now it is known that this is a normal reaction. However, airsickness, like seasickness, may be more readily induced by a faulty balancing apparatus located in the middle ear. Disturbances of the ear are among the most trying problems of aviation medicine.

The external ear, eustachian tubes, and ear drums are carefully examined and hearing is tested. If the applicant can hear the whispered voice at 20 feet, he is rated as having 20/20 or normal hearing.

There are two equilibration tests, one which the reader can try. The candidate stands on one foot, closes his eyes, and attempts to remain balanced for 15 seconds. He may aid his balance by moving his arms or his raised foot. He is listed "steady" when he does not move appreciably, "unsteady" when he has difficulty in keeping his balance, and "failed" when he is unable to maintain his balance for 15 seconds in one of three trials for each foot.

The examinee is next given the Barany chair test. If he has a history of train sickness, seasickness, swing sickness, or airsickness, such weakness may be detected. But there are other factors that may operate to cause these disturbances.

The Barany chair has a head rest which brings the candidate's head forward to 30 or 40 degrees. He sits in the chair with his head on the rest and closes his eyes. He is turned to the right and asked for his sensations. If normal, he will reply that he is turning left. The test is used to convince young pilots they can't rely on their equilibrium sensations in flight.

Next, the chair is turned 10 times

in exactly 20 seconds, a stop watch is clicked, and the applicant looks straight ahead at some distant point. If horizontal oscillation of the eyeballs (nystagmus) continues for 26 seconds, the candidate is normal. He is then spun in the opposite direction, nystagmus is again noted, and pulse and blood pressure are taken. If the time of the nystagmus varies more than five seconds between the two directions, the applicant is disqualified.

PILOTS must have good ventilation at all times, and the nose, throat, and lungs are carefully examined. Any acute or chronic defect of the nasal passages will disqualify. The lung capacity is tested by exhaling air into a spirometer after the deepest possible inspiration.

The flyer should be thoroughly sound physically and mentally because of the strain of flying and the unusual pressures and stresses he endures. Fighter pilots, for instance, are subject to "bends." A modern combat plane can carry a pilot several thousand feet high in a minute. Because of this rapid ascent, the flyer undergoes sudden extreme changes in pressure, such as a diver encounters.

Fatigue incident to the stress of military combat is still another problem. The combination of nerve strain, fatigue, and fear of an aerial combat



This flight candidate is tested for nervous control. His outstretched hands must show very little, if any, nervous reaction.

may result in a crack-up when the exhausted flyer returns to the field in an otherwise uninjured condition.

Ideal pilot material would be a man between 21 and 25 years, with good eyes needing no correction; little history, if any, of nose, throat, or eustachian tube infection; good heredity, and plenty of physical stamina. The man need not be tall; rather, he should be wiry and possess a great deal of endurance. He must be able to preserve his reasoning under trying conditions; he should have quick instinctive reactions and be a good judge of distance. He must be sound physically and mentally in every respect.

THE END

On the Light Plane Tarmac

WHAT THEY ALL THINK

DURING the past few weeks the conductor of this department has visited airports, talked to operators, and sat in with students between flights. He has been able to get them in groups and singly and talk over their problems, and the one that stands high above all is that which concerns their status if war comes.

In the first place, when light plane flyers speak of war they speak generally. No enemy is named and no particular war is ever mentioned. If they are asked what war they expect, they all look rather sheepish and avoid a specific answer. If you ask whether they expect to go abroad to fight, they ignore the question. If you suggest that perhaps they fear invasion of this country, they switch the subject quickly. Unconsciously, then, they are avoiding the one point that will play the greatest part in their aviation lives.

If Great Britain is beaten to her knees and gives in to the gang of European Dictators she is now facing, the next step these Dictators will make will be to dominate the world's foreign trade and make moves to take over the control of the Western Hemisphere. If this happens, it means that the United States will be in exactly the same position France and Britain found themselves, and the United States will have to make up its mind whether to fight or sit back and let the juggernaut roll on.

If, on the other hand, war breaks out in the East and involves the United States, another situation will arise. In the Pacific it will be a naval war with very little land action.

If the United States goes overseas to Britain's aid, the situation of the American light plane pilot will be something else again.

The flivver flyer likes to consider himself an important cog in the American air defense. He has a certain amount of flying skill and has had a few lectures in engines, instruments, meteorology, air law, and theory of flight. He can take a light plane off the ground, put it through a few primary aerial evolutions, and bring it back to earth again. In some cases he has done cross-country work under ideal conditions and has performed further required aerobatics. As such, then, what is his place in the scheme of national air defense?

As he stands with his amateur or private license in his hand, he represents very little. He, in most cases, is not a good or valuable mechanic. He knows very little if anything about machine guns, bombs, or fighting tactics. He has never flown at a speed much over 100 m.p.h. and he has seldom been in the air for more than an hour at a time. And from personal examination, few of these men who have obtained this training, either through their own efforts or through the generosity of the Government, have very much desire to have anything to do the military.

Most of them take the same stand that the usual newspaper and magazine writer assumes. Many journalists today believe that in case of war they would all overnight become glorified war correspondents or highly valued members of some mysterious propaganda bureau. Today, many light plane pilots believe that

they are destined for some safety-first job such as delivering planes from factories to fields, flying air ambulances, or overnight taking over the duties of test pilots. A few agree that they might become primary instructors, and honestly believe it their right to these jobs because they took up flying before the actual war was declared. Only a few indicate that they would prefer to become fighting pilots and take the air in actual defense of the country.

However, regardless of what we may desire, none of us will have much choice in the matter, the compulsory training system being what it is.

But let us take another look over this situation and see just how valuable the light plane pilot is under the glare of national defense.

In the first place, he at least has some air sense. He has been in the air and knows what air-feel means. He is at home in a cockpit, whether as a passenger or pilot, and for that reason he will make a good military airman, whether he wishes to or not. He can quickly be turned into a gunner or navigator. He can overnight be given some experience as a bombardier or can become a radio operator or flight engineer. It will not be necessary at first to train him as a pilot. He will be better off getting more air experience as a crew member until he is prepared to take further flight instruction.

What we must remember today is that air strength is not simply a matter of counting up the number of planes and pilots available. We must also consider the required ground crews and the other flight members who are so necessary. Now that bombers are being turned out as fast as fighters were built a short time ago, we must in turn produce flight crews to man them. It will not

New light planes are still being turned out, but they all seem to have that same you-know-what appearance. The latest is the Interstate Aircraft & Engineering Corporation's S-1A Cadet. Maximum speed with the Continental 65 is 107 m.p.h. and cruising speed is 100.



surprise us a great deal if many of the light plane pilots of today are rounded up and given hurried training long before they are offered the chance to take military pilot training. This may seem like a hard view to take of the matter, but we are considering the importance of aerial defense and not personal sentiment.

If America must defend her own at home, the situation may be greatly changed. Then we shall require as many defensive fighters as we can gather and they will have to be flown by pilots. In that case we shall want single-seat pilots, or at best two-seat fighter crews and less bomber groups. Then, moreover, flivver plane pilots will most likely be snatched away from their civilian jobs and rammed through short, intensive fighter-plane courses and sent to one coast or the other. If this war they all fear breaks out in the Pacific, we shall see more naval engagements and of course some naval air activity. These will be carried out by Navy personnel, of which at present there is plenty to man the equipment available.

My readers will perhaps argue that light plane pilots in Canada and Great Britain have played a big part in Britain's gallant war in the air, and that many of them are first-line pilots flying the best the British can produce.

That much is true, but we must remember that light planers trained throughout the Empire were not coddled into any false sense of security by telling them they were to be instructed simply to fly light planes for pleasure and with no strings attached. There, the light plane clubs were openly government supported and they were openly given primary military training and put through primary military flight tactics. They were taught the theory and use of machine guns. They learned to detonate and load bombs. They were given blind-flight training very early, and they carried out mass formation flights under exactly the same conditions that RAF cadets were taught at Cranwell. They used the Wimperis bomb sight and dropped dummy bombs. They signed on to become members of the Royal Air Force Volunteer Reserve and as such were real timber for the first-line squadrons.

Very few light plane pilots who are getting free flight training in the U. S. today have ever seen a bomb or a machine gun on a military plane, let alone absorbed the many technical details. In Great Britain, however, even the women members of light plane clubs were capable of acting as ferry pilots and are delivering advanced trainers from the factories to the training fields. How many women pilots in this country could fly the average advanced trainer of the N.A. type?

Our light plane pilots can become important factors in this business of national defense, but they should be taught more than figure-eights and three-point landings.

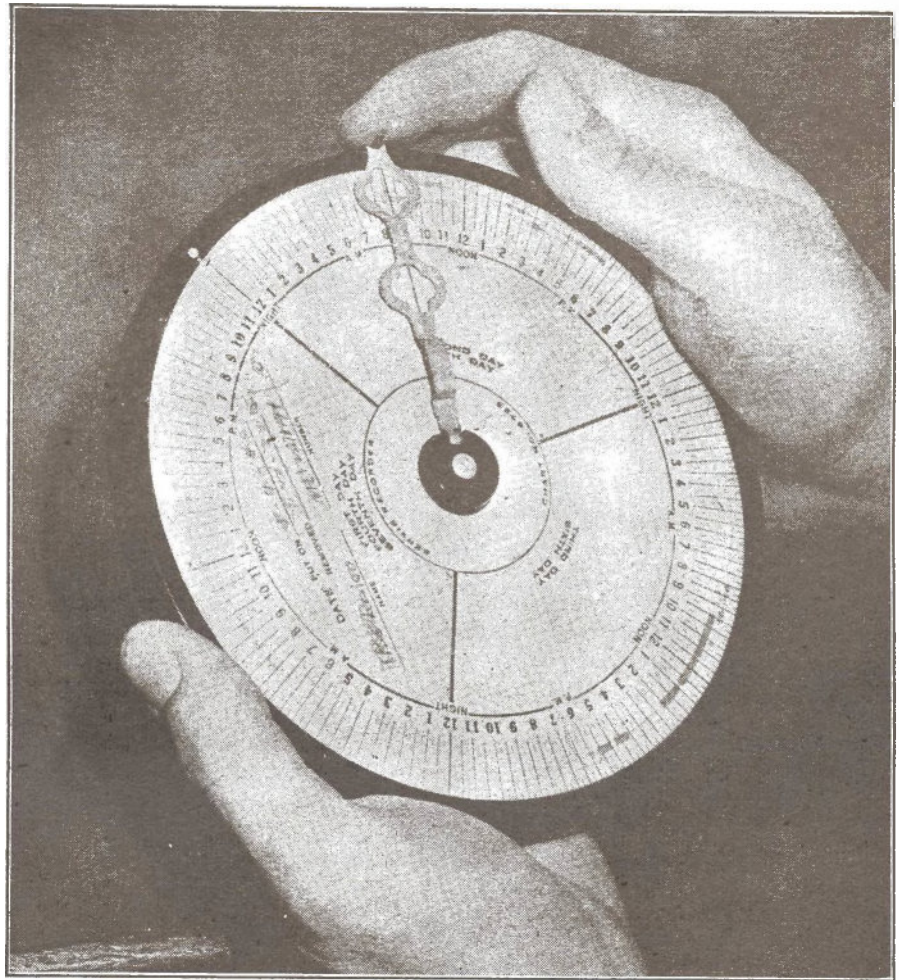

Now you can rent a plane for the week-end, bring it back when you're ready—and pay only for the actual flying time! This new system was started by Howard Ailor of Roosevelt Field and is called the Ailor-Fly-Yourself-Service. The gadget pictured here does all the timing.

YOU CAN'T GET PLANS!

WE ALSO wish to get some of our light plane fans out of a beautiful dream they have been slumbering on for years. It's about this business of getting blueprints from manufacturers and building your own light plane from them.

This department for years has been receiving requests for the addresses of certain firms and questions as to whether that company would give or sell sets of blueprints on their planes. The idea is, we presume, that the receiver would take the prints, nail them up on a barn wall somewhere, and gradually collect enough material to build a plane and fly it at his own convenience.

This might have been all very well back in the dizzy Twenties when the Heath and the Corbin Ace planes were produced mainly for the knock-down-kit market. But all that is over now. And while some of our readers may be terribly disappointed at it all, we must remind them that whatever they build today in the way of flying craft must pass Government license test.

But let us look at it from the manufacturers' angle:

The Piper or Taylorcraft companies spend approximately \$100,000 every time they produce a new type. Much of this goes into blueprints,

experimentation, stress analysis, and primary testing. The blueprints required even for an ordinary two-seat light plane make up a tremendous bundle of paper, and when you read—in fiction—of the blueprints of the latest bomber being stolen, you can figure that the thief in question probably used a ten-ton truck to cart them away.

Can anyone, then, with any reason at all, believe that a manufacturer would give away, or even sell, a set of these blueprints—even if you could afford to buy them?

"FULL LEFT AILERON"

CARE and thoughtfulness are two things we always stress in this department, regardless of what else we might say. And here is a letter that shows why we continually keep harping on those subjects. It carries a good lesson; one that should be learned by all who putter around with light buggies.

Light Plane Editor:

The date in my logbook is May 7, 1939, nearly two years ago. I was flying an Aeronca Continental-powered "50" in Gallup, N. M., for spins.

Since the airport is 6,500 feet above sea-level, it took me nearly forty-five minutes to reach a safe altitude of

(Continued on page 79)

SKY SABOTAGE

Somehow, a complete squadron of Army Air Corps Douglas bombers had been stolen! Where they were or who wanted them was a mystery as deep as the Griffon's guarded identity. But the scarlet-masked night flyer wanted one of those puzzles cleared up—and he stretched out and put his ear to the ground!

by Arch Whitehouse

Illustrated by Alden McWilliams

The battered Douglas screamed toward earth just as the figure broke free and pulled the chute's ripcord!

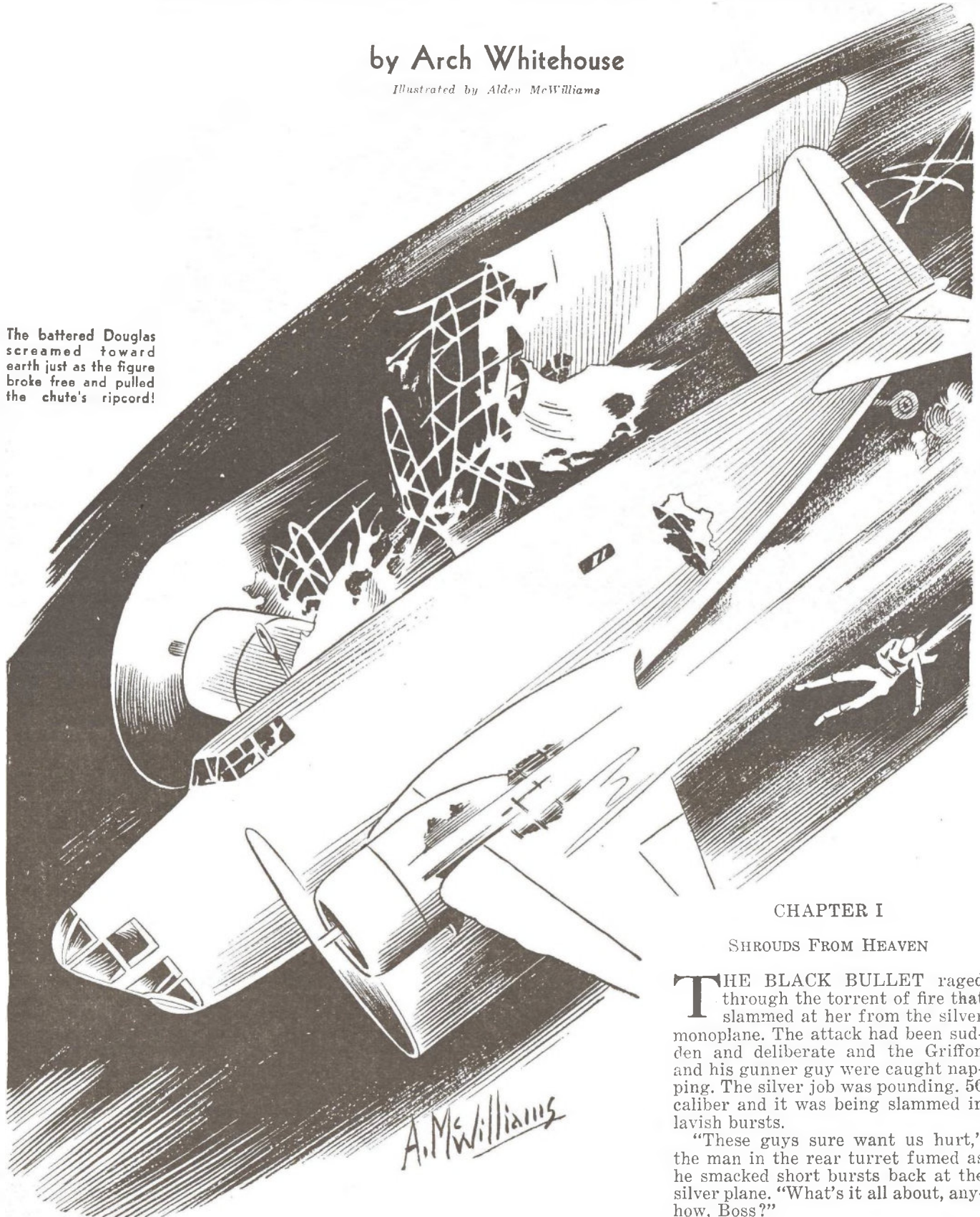

CHAPTER I

SHROUDS FROM HEAVEN

THE BLACK BULLET raged through the torrent of fire that slammed at her from the silver monoplane. The attack had been sudden and deliberate and the Griffon and his gunner guy were caught napping. The silver job was pounding. 50 caliber and it was being slammed in lavish bursts.

"These guys sure want us hurt," the man in the rear turret fumed as he smacked short bursts back at the silver plane. "What's it all about, anyhow, Boss?"

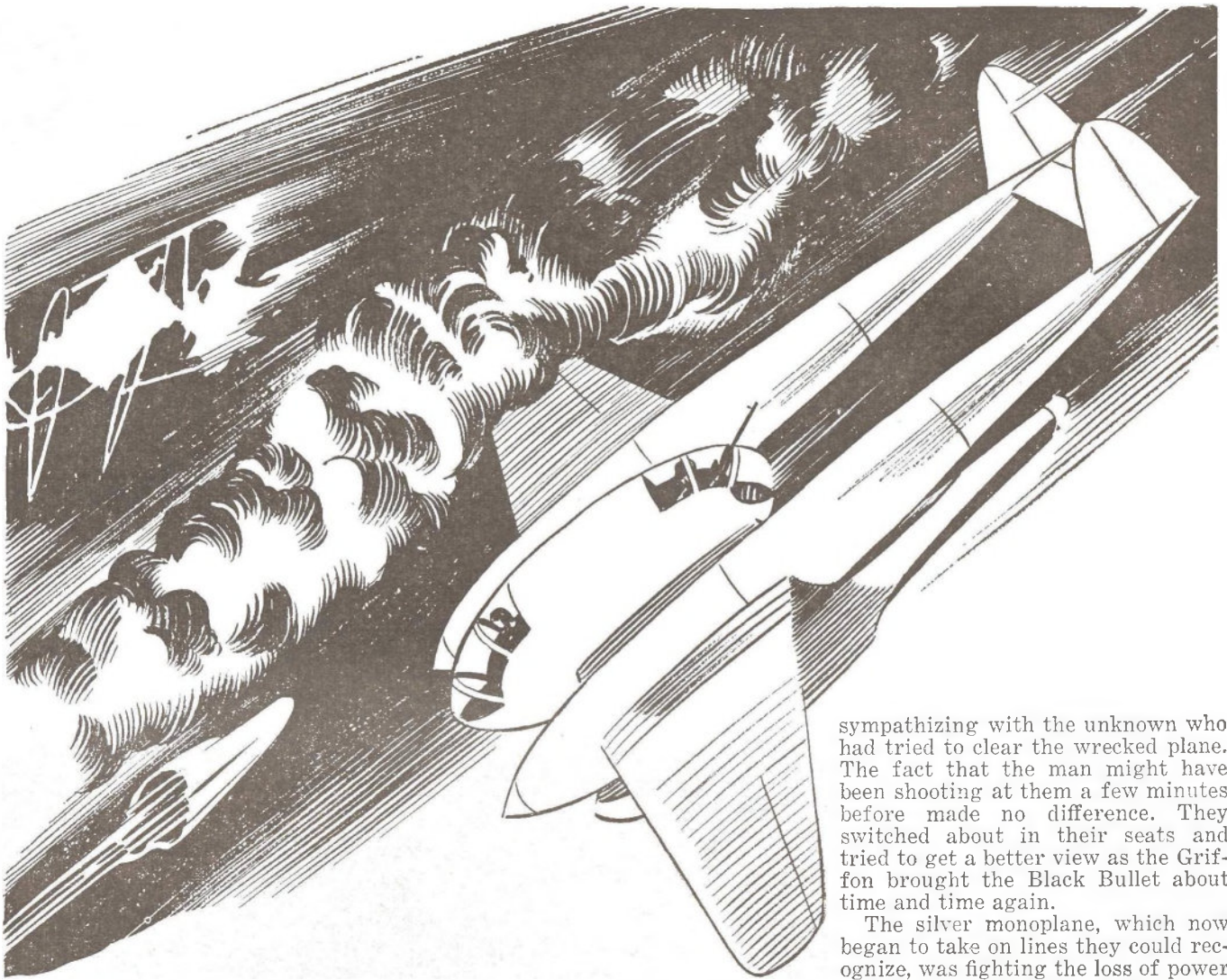

"Don't ask me," the Griffon called back. "You keep them off while I try to get a shot in with something that will make them squeal."

The crazy engagement was taking place at about 14,000 feet, twenty miles or so off the Long Island shore. If anything slipped up this time, there would be no gliding home with a tail wind. They'd wind up in the drink and get nailed cold by the Coast Guard. And regardless of the outcome of this battle, the Griffon wanted no part of the Government forces. That would kill his act completely, and they might find a few extra charges to slap on his record.

The gunner guy aft took a long deliberate aim and spanked off another chattering burst from his Brownings. The twin streaks forked out madly, crossed about 150 feet ahead, and then opened up again and bit deeply into a section of rounded fuselage. The enemy gunner let drive with a screaming packet in return and then folded up with a scream.

The Griffon whipped the Black Bullet over, dragged back on the control column, and then managed to get a short but effective burst into the monoplane which had a lot of features of the Douglas B-18. The thud of the heavy stuff rang out across the sky and the Bullet let her nose drop while the Griffon brought her around again

and allowed his gunner to spank off a few more.

"We got her, Boss!" the gunner guy grinned. "She's acting queer!"

The Griffon looked and fought to get his nose up again, but suddenly the silver monoplane above seemed to ignite and gush with flame. There was a dull choked boom and a jet of flame spat out from behind an engine. The gunner guy gave her another slamming and then held off and watched.

"Wait a minute. Don't shoot again," the Griffon ordered.

"What's wrong, Boss?"

"Give the mug a chance. He's trying to get out of that small window."

"No guy can get out of that space, Boss!"

"Well, someone's trying to. Look!"

They curled around and watched the hopeless effort which was brought out in cruel relief by the flame from the burning engine. They could see a figure struggling to get out. An arm appeared and then a leg. The glare increased and the arm and leg disappeared again.

"That bum's licked, Boss," the gunner guy observed as they circled closer to the winged parcel of doom. "He'll never get out of there. Why don't he go forward and try an emergency hatch somewhere?"

They waited anxiously, somehow

sympathizing with the unknown who had tried to clear the wrecked plane. The fact that the man might have been shooting at them a few minutes before made no difference. They switched about in their seats and tried to get a better view as the Griffon brought the Black Bullet about time and time again.

The silver monoplane, which now began to take on lines they could recognize, was fighting the loss of power and fast reaching the point where she would break up. They were certain now that it was a Douglas B-18 with something unusual in the way of gun turrets. The flame from the burning engine egg was getting more fierce and a pennion of scarlet and gold was licking back almost to the small opening where they had seen the pathetic figure attempting to get into the clear. It was apparent she wouldn't last long now.

Suddenly, the Griffon let out a low cry. They both started up into the glare of flame and illuminated dural above them.

"He's hacking his way out. Look!"

Flame illuminated the last phase of the mad goings on above them. They could see a gash slowly being hacked out of the gleaming side of the fuselage and a Vee-shaped notch gradually widened like something being produced with trick lights.

He's gonner get away with it!"

"He deserves to. We'll pick him up!"

THEY circled once more and came around just as the big Douglas began to flounder. They waited anxiously and then saw the figure hurl itself clear and topple away into the darkness, just as a wing tank blew up with a gangling roar. The figure disappeared into the darkness.

The Griffon drew the Black Bullet

away to clear any tumbling debris. A mad fluttering blanket of burning fuel slithered across the sky, and for an instant they saw a billowing canopy of white break out below and a figure swing from the shrouds.

The Griffon turned fast and stared anxiously at his gunner. "What did you see?" he demanded.

"I think I saw it, too, Boss—a woman!"

The Griffon wheeled the Black Bullet again and they drew in close in an effort to get somewhere near the drifting figure. The silver monoplane had broken up completely now and was throwing itself all over the sky in large chunks. There was still enough glare in the sky to keep track of the white carnation that was dropping slowly toward the sea.

They lowered the retractable pontoons to the Black Bullet and moved in closer to assure themselves from the dangling outline that the figure in the parachute harness was actually a woman. They could see the mane of light hair that billowed and flowed from her head. She appeared to be wearing light polo boots, riding breeches, and a tweed jacket.

A chunk of the burning bomber raced past her dangerously close and smashed itself with a roar into the sea. It floated there for a short time and provided a gleaming marker of flame by which the Griffin could set a position. The girl drew in the shrouds, fluttered clear of the wreckage, and then dropped gently into the water.

"I hope she can swim," the gunner said.

"She'd better! Quick, behind you!"

The next few minutes were madness souped up to the limit. The gunner guy suddenly swung around hard and jerked at his Brownings. They spat wickedly, and two streams of .30 caliber stuff fanged hard into the nose of another silver monoplane.

"Hold them off—somehow!"

"You going down after that girl?"

"Sure! We've got to find out who she is and what this is all about."

Another rattle of gunfire and the silver monoplane sheered off and gave a rear gunner a chance to splash some venom. The Black Bullet guy smacked a short burst at her and the silver monoplane nosed around hard and disappeared through a jagged column of smoke.

"We got one dame to worry about already," the gunner argued.

"We'll worry for weeks, wondering who this one was, if we don't get her now," the Griffon argued in reply. "Now shut up and try to act sane, for a change."

"Not me. I've seen too many sane people. I don't want to be like that. Sooner be crazy!"

The Griffon gave up and turned his attention to their landing.

The Black Bullet skittered across the rollers and thumped her step hard on a whitecap. The Griffon caught her nicely and held off long enough to make a reasonable landing. She dropped, threw out two arrow-headed sprays and settled down. Then the Griffon jiggled the throttle and brought her up close to the sodden parachute that lay across the water. The girl had managed to clear the tangle of shrouds and was swimming calmly with smooth overarm strokes. The Griffon eased up and brought the pontoons of the Black Bullet into position skillfully, and the girl was able to throw an arm over the rear portion and hang on.

Then the masked night flyer drew his hatch cover back and stared down. He leaned over and started to put out a hand to the girl who had climbed up on the pontoon. He grabbed, but gasped in utter astonishment: "Holy Christmas! Pebbles!" he ejaculated.

The girl simply nodded, hung on to the side of the hatch frame, and then bowed her head on her elbow.

"Golly," she finally managed to say. "Am I glad you turned up!"

The gunner was out of his seat and in semi-hysterical Celtic was gabbling about like a mothering duck. He had his heavy wind-breaker off and was wrapping it around the girl. He hoisted her up into the space between the two seats.

"How the devil?" the Griffon was saying.

"Don't ask me. It was crazy," she said, huddling down. "Get me somewhere where I can change and get warm."

She turned her head away and found herself facing the open neck of an O'Doul's Dew bottle.

"Drink ye this," Barney O'Dare ordered. The Mick was playing the part he really loved.

They packed her in closely and then shut the hatch tight. Kerry Keen slammed the sauce to the big Allisons and they were thumping away over the rollers again and holding for altitude.



THEY WASTED no time getting back to Graylands, although Keen used every precaution to make certain they were not followed or spotted. He shot north at first for Montauk, swung suddenly in the beam of the big light, and then nosed down and cut in the Skoda mufflers. The Black Bullet had disappeared in the darkness and silence, but was actually cutting south for Graylands.

Keen's mind was in a terrific turmoil as they zipped for his secret landing place. He was certain all this meant danger and trouble in large juicy chunks. He did not question the girl at all but tried to piece it all together as he put the Black Bullet

down, ran her out of the surf and up the sandy beach, and then past the boathouse to a point on the lawn which faced the big rockery.

The Mick climbed down, pressed a hidden switch, and two massive doors opened in the rockery, revealing a slanting ramp down into the cellar of the house. They quickly folded the wings back and Keen ran the Black Bullet inside while Barney O'Dare closed the doors again.

"Come on, Pebbles. A quick, hot bath for you and then we'll find out what this is all about."

The girl, stiff and weary, made her way up the stairs and hurried into a bathroom. Keen went to another room and found some dry clothing, warm stockings and sweaters Miss Colony kept there for use when she stayed out at the Long Island establishment. These he piled up outside the bathroom door and then went below to his study again.

The Mick was there, bottle and glasses ready, but his face was ashen and drawn.

"Thanks, Barney," said Keen. "I need this."

They poured drinks and mouthed a silent toast to their good fortune.

"And what does all this mean, Boss?"

"Trouble, I'm afraid."

"How did she get aboard that lugger?"

"I don't know. Not by desire, I'll bet."

"They're after us, Boss."

"I know it. We've got to be ready for anything. Make sure the Bullet is ready and have a car standing by. We may have to beat it at any minute."

The Mick padded off to prepare for the worst, and Keen tried to figure it all out. Why was the Black Bullet attacked in the first place? They had been out on a short run, mainly to keep their hands in. The plane had been overhauled in the past few weeks and the night had offered just the conditions they desired. What had started out to be a quiet little flip for test purposes had suddenly turned into a mad adventure, with a climax that had left both of them practically speechless. And why had Miss Colony been aboard that plane? How did she get...

The telephone bell jangled and interrupted Keen's thoughts.

Keen picked up the instrument and caught the voice of John Scott, head of the F.B.I. in New York city.

"Good evening, John," said Keen. "What's on your mind?"

"All the rot in the world," Scott said. "Why does everything happen to me?"

"You should come out to the country and live a quiet life."

"We're in trouble, Keen," Scott said, ignoring the quip. "I simply have to talk to someone about it. Why did they ever invent airplanes, anyhow?"

"Not having ever been very near one," lied Keen, "I wouldn't know."

There was a muddled silence from the other end and Keen smiled to himself. He knew he was suspected, but neither John Scott nor his side-kick, Drury Lang, could quite figure out how Keen, if he was the Griffon, could outwit them so often and so completely.

"Look, Keen," Scott began again. "Lang's missing!"

"Missing? Better put a dragnet through the nearby breweries."

"This isn't funny. I've got him missing and a whole squadron of Douglas bombers."

Keen whistled softly and then let Scott continue.

"We had a complete squadron of Douglas B-18's on the way out from the coast. They were supposed to have pulled in as new equipment at Mitchell Field. Not one arrived, but they left Chicago okay!"

"What does that have to do with Lang?"

"He went over there on a routine job, and then just seemed to disappear completely. We have no news of any sort on him in about sixty hours, and you know that's not like Lang."

"Well," laughed Keen, "I know nothing about it."

"I know," agreed Scott. "Very few know anything about it yet. I just called to find out if you had any ideas about it. A new viewpoint might help, you know."

CHAPTER II

RUMBLINGS IN THE GROUND

KEEN PONDERED on it a moment and then heard the door creak. It was Miss Colony coming in, swathed in a warm bathrobe, her hair tied up in a towel. She reached for the bottle and poured herself a drink as Keen smiled at her.

"Why doesn't anyone know anything about it?" he asked Scott.

"They're lining up the Air Corps for the Eastern Seaboard war games. We expect to have a lot of stuff here to carry out a City of New York defense problem and there has been a lot of hush-hush about it."

"Well, maybe the squadron of bombers received hush-hush orders and has landed somewhere else," Keen suggested.

"That's reasonable, but where could anyone hide a full squadron of bombers?"

"That's just it. Hiding a whole squadron may be easier than hiding one or two. You don't have to hide a squadron; people just take it for granted."

"You have something there," beamed Scott from the other end. "That's an angle I never figured on. With planes flying east from all over the country, a whole squadron could sit down somewhere and just be expected. You see what I mean by getting another viewpoint?"

"I get it. If you hear anything about old Lang, let me know, will you?"

"I'll let you know if I *don't*," Scott

How Boeing Builds Them

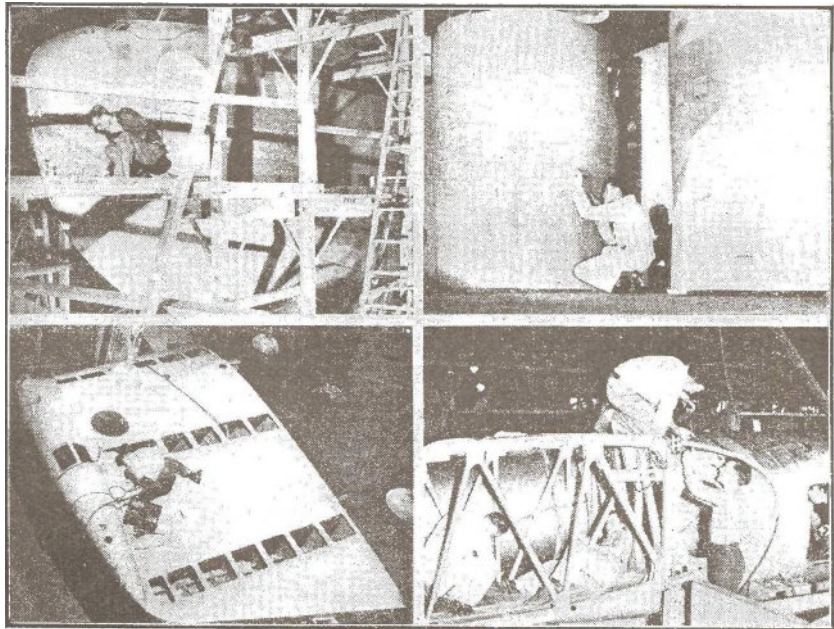

THESE photographs illustrate construction work on the six new giant Boeing Clippers which, according to Company publicity, will be delivered to Pan American Airways system before mid-year. And like the 314 flying boats already in service with PAA, these ships will be used for transoceanic passenger service.

Upper left: This is the bow of one of the 42-ton 314-A's, still encased in the scaffolding of the main hull jig. The scaffold members are numbered and named and the entire unit can be dismantled and easily set up elsewhere.

Upper right: No, these sections aren't part of a fuselage—they're merely assemblies for the engine nacelles! Four power plant streamlines are spaced along the 152-foot

wing of each plane. They house the four 1,600-h.p. Wright Cyclone engines.

Lower left: Technically known as a hydrostabilizer, this panel also is a sizable fuel tank. The new planes have a total gasoline capacity of 5,400 gallons, which is enough to fly non-stop from New York to Lisbon—with a good thousand miles to spare.

Lower right: Pan American wants its six new Clippers in a hurry and Boeing would like to clear its plants to concentrate on national defense production, so mechanics work elbow to elbow. Here on a wing-stub is a riveter, his bucker, and two men installing a wing fuel tank. The Clippers are being completed considerably ahead of schedule.

answered, hanging up.

"Why didn't you stay in Florida?" snapped Keen at the girl who was snuggling up on the couch in front of the fire. "See all the trouble you started?"

"I *did* stay in Florida," Miss Colony argued.

"Well, what the deuce were you doing aboard that bomber?"

"Hijacked. Hijacked out of the Tropical Country Club at Palm Beach. I was called to a phone in the hallway and then found myself with a blunt weapon in my ribs. They quietly walked me out to a car and drove me about ten miles, I'd figure. They had me blindfolded, and then stuck me aboard that Douglas and started asking questions about you."

"All right," said Keen, moving over. "Talk fast and tell me everything. There's a whole squadron of those babies missing. Also, old Lang

hasn't turned up in about 60 hours. Let's have it fast."

"The bomber was in an open field, some distance off a regular road. I could tell that from the bumps."

"When was this?"

"This afternoon. They went mad trying to get me to tell them who this chap the Griffon was and where he could be found. All this took place in the forward navigating compartment. I told them you were just a nut about guns and that sort of thing. Quite harmless, but often used by the police when they got stuck with a shell they didn't know what to do with."

"Thanks. That was nice of you," grinned Keen.

"But they were certain you were the Griffon."

"And you told them what?"

"That they were crazy; that you
(Continued on page 68)

Get That Aero Job

Our aviation plants are humming at top speed on huge contracts and there are numerous openings for skilled and semi-skilled men.

by George H. Tweney

Aeronautical Engineer



The U.S. Air Services offer about the best opportunities. Cadets are paid \$75 per month during the training period.

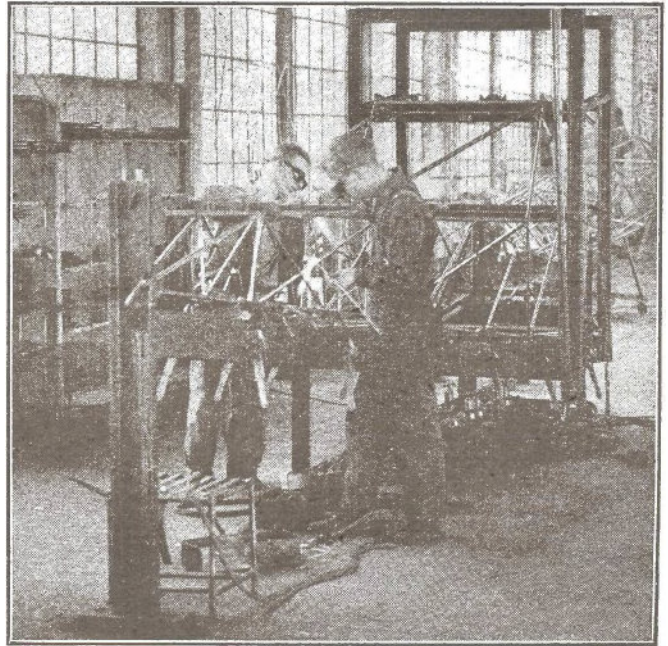

Welders are in great demand. This work is not very difficult, but it does require thorough schooling.

AVIATION has grown by leaps and bounds in the last few years, but all of that is really nothing more than a mere scratching of the surface. New plants virtually spring up before one's very eyes, and the game is calling to the youth of America to climb aboard the bandwagon. The prospects are bright, and now is the time to decide whether or not *you* are to share in this future.

But, you might ask, just what chance do I stand of getting into aviation? The answer is that your opportunities are practically unlimited, depending only on your own desires and initiative. Aviation is expanding rapidly in all branches, and you have practically your own choice as to the type of work you wish to do.

The manufacturers are today clamoring for help. A person skilled in almost any of the mechanical trades need only present himself at any of the larger aircraft plants, and he can be working within a few hours after filling out an application. In general, men who have had training in any of the aviation ground or trade

schools are preferred, although this is not absolutely necessary.

Wage scales among the manufacturers are fairly good, although in some phases they could perhaps stand a little improvement. Production and semi-skilled workers can start at an average of fifty cents with time-and-a-half for overtime.

Of course, specialists in many trades, such as machinists, tool and die makers, mechanics and engine installation men, and electrical men can demand much better wages than the average worker; and in some cases they may go as high as a dollar or a dollar ten an hour. This, of course, applies only to men who have had experience and can be trusted with detailed and precision jobs.

It is the general feeling among the industry that technical and semi-technical jobs offer the best opportunities and the best pay. A man interested in engineering can make no better choice than to study aeronautical engineering in some recognized university or college. A young engineer can start in the industry at a

salary ranging from \$125 to \$140 a month. And after two years, this may range as high as \$200 or \$215 for those men who have specialized in some particular branch of the science.

Requirements for this branch of the industry are very exacting, and only the best type of men can hope to reach any ultimate goal. However, this so-called "toughness" is encountered even before college days are completed, and usually the universities will graduate only those they feel are competent.

Stories of only eleven graduates in an original freshman class of one hundred students are common in most of the better universities. However, the student with a good scholastic record need have no fears about holding his own, even though the competition is keen.

TRANSPORTATION is growing so fast that the aero industry itself can hardly keep up with the developments. If you are interested in this type of employment, by all means

work towards an airline position.

The demand for personnel is not quite as urgent among the airlines as it is among the manufacturers, but a well-trained man or a man with experience can usually land a job.

There are two distinct types of work in the airlines, either Operations or Maintenance. A Maintenance candidate must have mechanical ability and must possess an Aircraft and Engine Mechanic's license. Ten months to a year in a good ground school can accomplish this, and then any of the larger airlines are open for your application. Transport Maintenance men usually start as Second Class Helpers, if they have had no previous experience, at an average salary of thirty-five to forty cents an hour. The next step upward is to that of First Class Helper, at a rate of fifty to fifty-five cents an hour. After that, Second Class Mechanics jump to seventy cents an hour, and a First Class Mechanic can earn up to a dollar an hour.

This type of work is very interesting and the working conditions are good. The constant rush of production as in a manufacturing plant is absent, but trip schedules must be met at certain times, which often involves long hours on the part of the Maintenance crew to get the ship on the line for service.

The Operations Department of any airline is a very intriguing place to work. Here you may be doing any type of work in a single day from dispatching to radio reception work and meteorology. You will be con-

stantly in contact with the traveling public and the work is very clean. This branch of the industry demands better men and pays poorer than probably anything else. Dispatchers are almost always required to be college men, and they very rarely start at a salary better than \$85 per month. However, this is but a stepping stone and proving ground for something better, and you may soon find yourself acting as Assistant Airport Manager or as a Traffic Representative. From this point on, the salaries improve considerably and in some cases even make up for the lowly beginning.

Meteorology and Airline Radio are closely related, and both offer interesting possibilities for the men who may be interested in this type of work. Remember, though, that college-trained men are the ones who are in demand, so if you are planning to enter this branch of the industry take a technical course specializing in these fields.

Little will be said about the flight positions that exist in the airlines, except that here lies the true "romance of aviation." Pilots and other flight personnel are selected types of individuals, and it takes long years of training and experience to get a job on one of our huge airliners. Most of the men who hold these positions today got their start as either Army or Navy pilots and they have many thousands of hours in the air.

All airlines are most particular about whom they hire, and a man must be physically and mentally per-

fect before he will even be considered. Pilots receive excellent salaries and wage scales vary anywhere from \$4,000 to \$15,000 a year, depending on the experience and responsibilities required. The actual working hours are short but you are away from home for a certain amount of the time, which may be a little disagreeable. However, if you like to fly, by all means start in early to acquire your experience and to build up flying hours. Also, seriously consider an Army, Navy, or Marine commission.

TALENTED young men with a technical turn of mind might relish the idea of getting into strictly research work. This demands an almost genius-type of ability in mathematics and science, and this is even more true of the aeronautical than of any of the other more basic sciences. The mathematics of airfoil design and air flow can become even more complicated than some of the higher hydraulics and electrical problems, and one can very quickly get himself into a practically impenetrable haze.

Probably the greatest opportunities for research positions are with the Civil Service Commission, which leads to either the National Advisory Committee for Aeronautics, the Material Division of the Air Corps, or the Naval Aircraft Factory. These groups are expanding rapidly, and this will be even more true when the new research center is completed at Sunnyvale, Calif. College men can secure appointments to these services

(Continued to page 80)

Engineers can always get a job in an aircraft plant. Salary at beginning is from \$125 to \$140 per month.

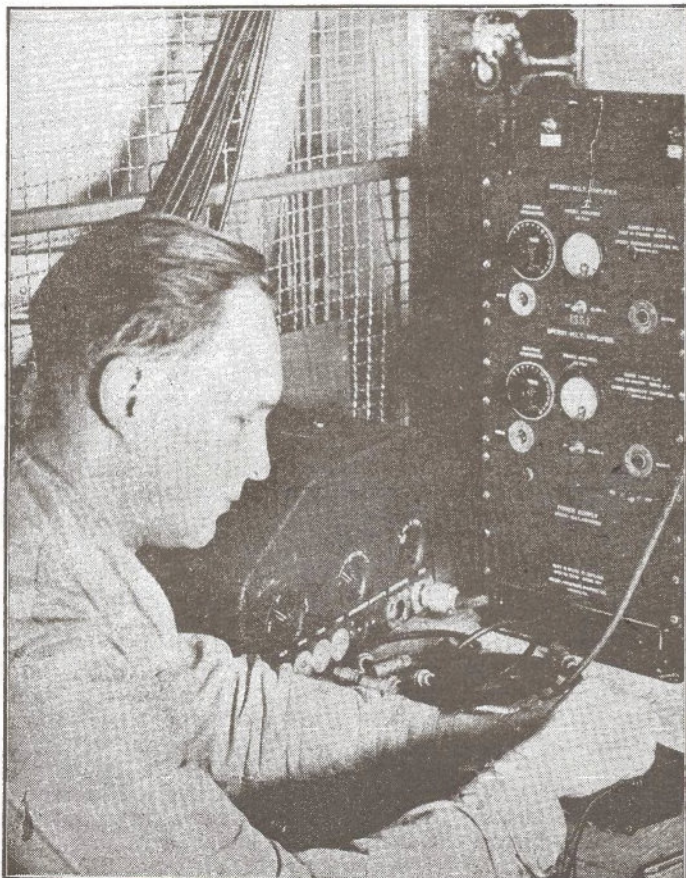

Mechanics have excellent prospects. Pay is from 85c to \$1 per hour, with time-and-a-half for overtime.

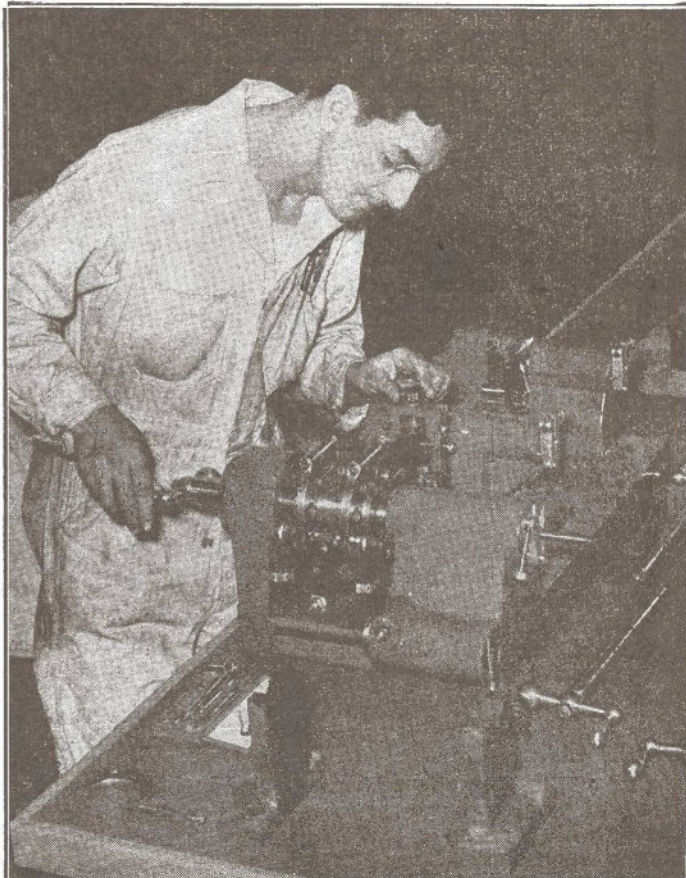

In the Slipstream

New Twists

Latest RAF weapon is an under-cowl gun which fires backwards. It's aimed via a series of mirrors. . . . Emergency bailing-out has been made easy on the new Airacobra by fitting of a special lever which pops the compartment doors off their hinges. . . . Binoculars enabling high-flying war pilots to see their targets in three-dimensional perspective have been patented by a Pennsylvanian. . . . According to a news story, the Zeppo parachute made in Greenville, Miss., will lower a man at the slow rate of "12½ feet a minute." You're right, somebody is screwy on that one. . . . A Clevelander has devised a paste-like substance which he declares will stop ice formation when applied to airplane wings. . . . Noiseless, smokeless, flashless A-A gunnery will be the next thing if the Rigby electric gun lives up to its inventor's promises. The bore of the weapon is strung with a series of electro-magnets designed to jerk the bullet through the barrel. . . . NACA studies indicate that a new type of cylinder cooling will now lead to 6,000-h.p. aircooled engines.

Bits About Flyers

Raymond Collishaw, famed World War Ace, is said to be commanding the RAF's desert sky warfare. . . . *Bernt Balchen* and *Clyde Pangborn* are busy ferrying Consolidated bombers from Bermuda to England. . . . *Charles Lindbergh* has resigned from the National Advisory Committee for Aeronautics. He's been criticized, yes. But if the aviation research facilities he urged some years ago had been established, our aeronautics would now be better off. . . . Movie dept.: They say *Laurence Olivier* is joining the RAF and that while still in this country he hired a bomber and chalked up 350 hours by way of preparation. . . . *Leslie Fenton*, former star and director, is now reported flying for King George. . . . *George Brent* is trying to build up air hours to keep his license—against the wishes of his studio. . . . We salute the memory of: *William Scott*, of the RAF, recently lost in action. He led the very first British air raid over Nazi Germany. . . . *Phil Leckrone*, Salem, Ill., member of the Eagle Squadron, who has been killed in a flying accident. . . . *Joseph F.* (only identification given) Czech Ace of the RAF, reported killed in action. He'd been credited with 27 Jerry planes.

On the Lighter Side

One of the Republic workers is so tired of having spy-guards juggle through his lunch box that he's getting a special Plexiglas box which

they can see through. . . . Aero subcontracting has gone so far that wine presses have recently been used to stamp out plane parts. . . . The Air Corps' new electric-wired underwear for aero flying is swell—just so you don't get a short circuit. . . . Bothered by light plane putt-putting, some gal has written the *N. Y. Times* that training planes should be made to "fly in long lines instead of circling." We can just imagine the instructors obliging with, "Bud, go up and do a figure 8 — but no turns or I'll bust you! . . . At Gotham's new Airlines Terminals (where porters are called Skycaps) the main wall comprises one-eighth of an acre of stainless steel colored with pure gold. Nope, aviation ain't what it used to be! . . . Meanwhile, our friends, the railway fans, are still at it. The Feb. cover of *Railroad Magazine* carries a heart-string-tweaking picture titled, "Grounded," which shows a skyliner down in a field and the disgusted passengers flagging a train. But the wing of the plane has such a goofy aspect ratio that it never could have gotten off the ground in the first place. So we don't blame the passengers for being disgusted.

About This and That

CPTP operators have now banded as the National Aviation Training Association. Bill Ong, of Kansas City, is president. . . . Ranked as a Naval Reserve Lieutenant Commander, Gene Tunney is now teaching athletics to Navy Sky trainees. . . . Bombay, India, is importing American sailplanes to groom British Empire flyers. . . . A couple of Bolos named Fomin and Boblishev claim a new open-gondola balloon altitude record of 36,300 feet. . . . At the time we write this, Jap air bombing has failed to put the kibosh on the celebrated Burma Road. . . . Mexico has begun its first naval-air base at La Paz, in lower California. . . . Our Army flyers are urged to learn Spanish. In line with the new Pan-Americanism, of course. . . . Thirty different kinds of iron and steel are used in a modern high-power aero engine. . . . Military job props are now painted dull black to prevent flashing, which is too easily seen by the enemy.

Prop Wash Patter

For firing without orders, British A-A Gunner A. E. Bennett was court-martialed the other day. But he wasn't punished because his shot blasted a Nazi out of the sky. "There he was buzzin' over," explained Bennett, "and I just couldn't let that chance go by" . . . Last reports (November) showed 114,745 Americans holding flying certificates — more than double the year before. . . . A

warning against aero racketeers has been issued by the NAA. The idea is that something so popular as our 1941 brand of aviation is quite sure to attract sharpers with schemes to get easy dough out of the public. . . . All private planes in Brazil were grounded on December 17 in protest against our Pan-American Aviation Day in honor of the Wright Brothers. Reason: The Brazilians contend that Santos Dumont (who hopped a job out of a Paris field in 1906) was really the first man to fly a heavier-than-air machine. They argue that no one knew of the Wrights' efforts until after the Dumont flight. . . . Because he made a bad error in flying, CPTP Student Perkins, of New York City, had to write an essay on the prevention of landing accidents. Anyhow, his essay turned out to be so good that the CAB is circulating it throughout the country. . . . Personnel of our Army Air Corps totalled 96,180 as of January 15. . . . More than 55 percent of the CPTP studes completing the secondary course have been accepted by the Army or Navy.

Here's a Break

—For those of you who are physically handicapped: Special flight tests for licenses have now been arranged. For full info, write the Certificate and Inspection Division, CAB, Washington, D. C., and ask for *Instruction No. 33*.

Wow!

Sidelights on that giant new Douglas B-19 bomber: There are nearly 3,000,000 rivets, 10 miles of electrical wiring, and 2 miles of control cables in the craft. And some 9,000 individual designing-and-building drawings were required—sufficient to cover 4 acres.

Nazi Air Fleet Roosts

Finally, we've nailed some info on the Nazi air force distribution. Air Fleet 1 is said to be in Eastern Germany; Fleet 2 in North France, Belgium, and the South Netherlands; Fleet 3 in Western France between Brest and Spain; Fleet 4 in Vienna; Fleet 5 in the North Netherlands, North Germany, Denmark, and Norway; and Fleet 6 in Rumania. Commanders of Fleets 2, 3, and 5—which fly against England—are, respectively, Field Marshal General Kesselring, Field Marshal General Sperrle, and Colonel General Stumpff. And how do you like that last name?

"You Figure It Out" Dept.

An Aero Chamber release says combat planes now being delivered to our services "are provided with fire power unsurpassed in Europe." But Bell Aircraft says the Army's now taking Airacobras without 37-mm. cannon because of a shortage of these guns. . . . From England comes a report of a sham battle between a Curtiss Tomahawk and a Hurricane. The RAF pilots partaking said the Curtiss proved superior in speed and
(Continued on page 65)

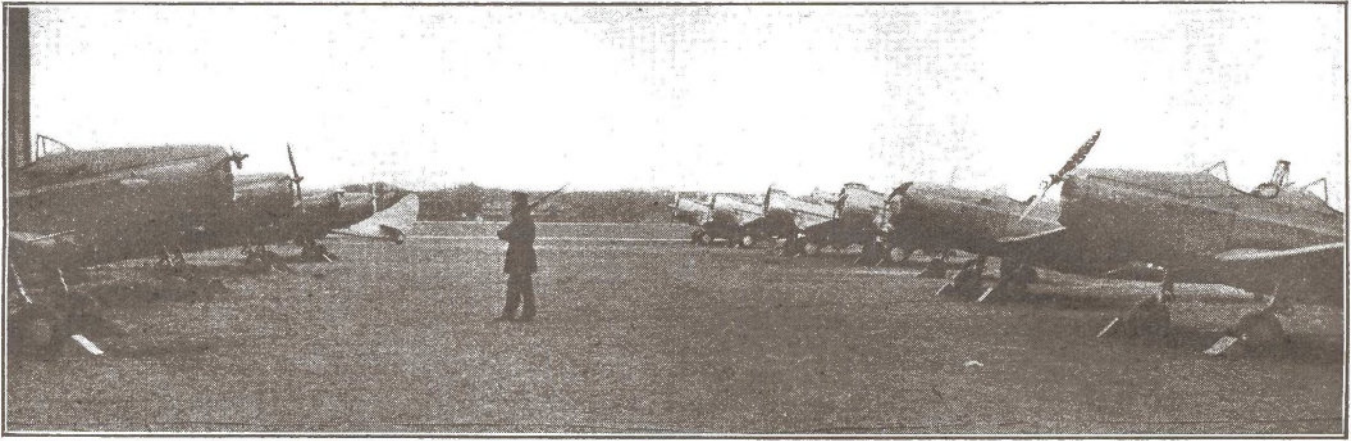

At the Toronto training camp, a lone Norwegian sentry guards the American-built Fairchild trainers and Douglas 8A-5 attack bombers.

NORSE AIR FORCE TRAINS IN CANADA

In "Little Norway" a new air force is being formed to combat Hitler's legions.

by James Montagnes

FAR FROM their native land, Norwegian airmen are building a new air force in Canada. Uniforms of naval and army pilots as well as Norse sailors are no longer strange sights on the streets of Toronto, where hundreds of Norsemen have started training new units of the Royal Norwegian Army Air Force and Royal Norwegian Naval Air Force.

About a thousand men are expected to be in training during the Winter and Spring in the camp which has been built near Toronto's Island airport. They have come from England after escaping from Norway. Some had their small ships sunk under them, others swam to Sweden after escaping from Norway. One group even stole a German plane, painted out the German markings, and made Great Britain.

The Scandinavians are training in planes their government ordered from the United States prior to the capture of Norway by Germany. These machines being delivered now include trainers as well as fast modern fighters, bombers, and seaplane patrol bombers. In all, about 100 aircraft are being and have already been delivered from United States' factories. It is not known what fighters have been contracted for, but they have Fairchild trainers, Douglas attack bombers, and Northrop seaplane patrol bombers. (A photograph of the Northrop, along with descriptive copy, was presented in the April issue of FLYING ACES.)

Norwegians formerly used British, German, and Italian airplanes. They are learning in Canada how to handle American-built machines and are training a ground force thoroughly acquainted with servicing American-made engines, airplanes, and accessories. They also train their own radio operators, gunners, observers, and navigators, basing the instruction on that of their allied air forces in Canada and Great Britain.

Heading all Norwegian fighting forces in Canada, and acting as liaison officer between the Norwegian government in exile at London and Ottawa, is General William Steffens, who was in charge of Norwegian west coast defense. In charge of the naval air force is Commander H. Riiser-Larsen, of North Polar fame, who went to the rescue of Amundsen and Nobile in 1928. Heading the army air force is Major Bjarne Oen who had his ship bombed from under him while escaping from Norway.

Eventually, when fully trained, the Norse airmen will take their place on the war front along with Britain's airmen.

THE END

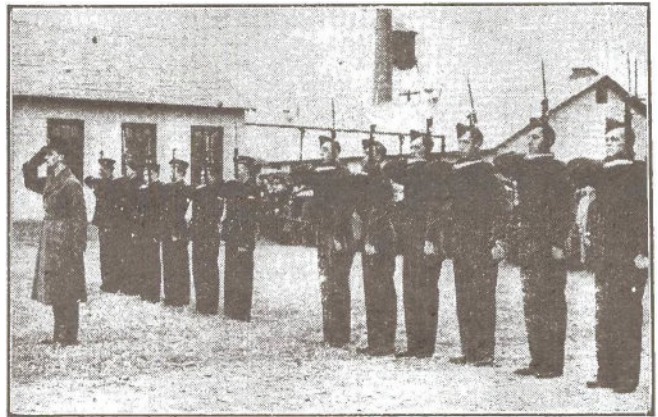

Norse naval uniforms have not been changed, but army uniforms are based on Royal Canadian Air Force tunics for officers and men. All Norwegians in training carry shoulder badges clearly marked "Norway."

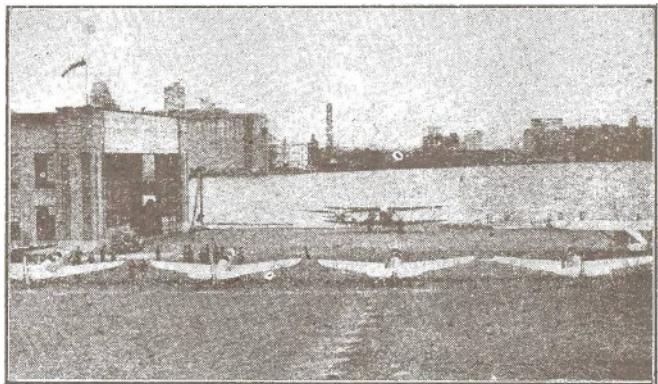

From their Toronto air base, both land and seaplane flying may be carried out. Below: Officers and men of the Royal Norwegian Army Air Force examine one of their Douglas machines upon its arrival.

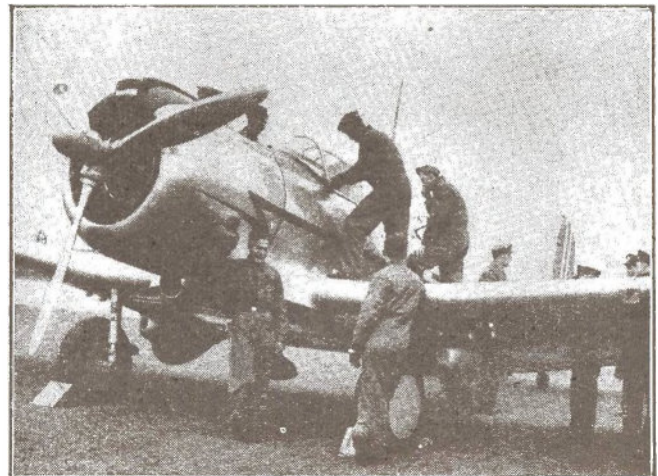

DAWN PETROL

OIL'S WELL THAT ENDS WELL!

by Joe Archibald

A GROUP of Allied officers were relaxing in a cafe in Bar-Le-Duc, France. They were there to forget the pyrotechnics furnished by the dynasties of destruction of half a dozen countries and to sooth their jumbled nerves with giggle water. Lieutenant Phineas Pinkham, of the Ninth American Pursuit Squadron, happened to be one of the customers of the Frog hot spot and he pricked up his big ears when he heard a Britisher lambaste a harried waitress regarding the omelet she had served him.

"The bes' in all France, M'sieu. Bah, vous do not know ze good *ouefs* when you eat heem!" the Frenchy protested.

"He is right," Phineas piped up. "I could saute an overshoe and paint it yeller and it would taste better. Bring me ze oofs and somebody give me a hat and I will cook up a better omelet in it without a fire!"

"Haw! Priceless!" ejaculated the red tab, taking a pull at his brandy.

"I am not kiddin'. Anybody who says I can't do it will get ten francs!"

Now there was another American in the cafe and he had a yen for picking up easy money. He was a Captain in the artillery and he needed ten francs.

"I'll take that bet, you big-mouthed sky buzzard," the Captain said. "Bring the garcong the offs." He picked up an infantry officer's cap and tossed it to Phineas.

Phineas was confident. He had pulled this trick on many occasions and it was one of the best in his repertoire. Simple enough if you knew how to do it, if your hands and eyes were up to snuff and had not been shaken by vin blanc. The Boonetown jokesmith carried a rubber omelet and two eggs, the insides of which had been drained out and the holes in them stopped up with wax. All he had to do was switch the eggs. But let Phineas show you.

Major Rufus Garrity's problem received the eggs with thanks and put them in the spacious pocket of his trench coat while he arranged the hat to suit him. He pulled out one of the good eggs and dropped it deliberately to show the gallery that the eggs were bona fide products of a real hen. He asked for another egg.

"Little nervous is all," Phineas chirped.

Another egg forthcoming, Phineas went to work. He drew a bogus egg from his pocket and broke it into the hat, threw the shells away. "One," he said. "Now for number two."

Phineas had one snort too many. He got mixed up on the second egg. When he broke it, the albumen and the yoke that dropped into the officer's hat was not kidding.

"Why—er—I never missed up on this before. I—er—" Phineas pivoted slightly, measured the distance to an exit. But he had one of his own countrymen to contend with. A big brass hat, bareheaded, stepped forward

and picked up the hat. He let out a leonine roar when he saw his initials in the hat and some of the egg yolk had smeared them prettily.

"Pay me ten francs," the Yank officer howled.

"An' I take a five pound note, blast your eyes!" the red tab yowled.

"M-maybe you think I run a foreign exchange store, huh?" Phineas protested. "Listen, can't you bums take a joke? I ain't got ten francs, and if I had a pound I'd buy a limousine. Look, fellers. Let's talk it over." Then he started running.

Phineas found the Yank officer in his way and he had to go through him. The mademoiselle and the little Frog manager of the cafe ran into the street, screaming for gendarmes. It was not quite dusk and Phineas had to forget the protection of darkness. He had to take the bull by the horns when it jumped in front of him, and there it was in the form of a nice new motorcycle. Lieutenant Pinkham usurped the mechanical bug and got its power plant stuttering. He went down the street in high and drove the populace to cover as if they had been startled pullets on a feeding ground.

THINGS might have turned out better for Phineas if he had headed southwest toward the Canal des Usines, but he pointed his ground looper toward the northeast where the canal strings along between the Marne and the Rhine. The Boonetown miracle man was four miles out of Bar-Le-Duc when the M.P.'s there finally organized a skeleton posse. It looked as if Phineas was in the clear, and then he swung around a bend in the narrow highway and met a four-wheeled jalopy that was not crawling any slower than he was. Something had to happen that was not good.

Brakes squealed and a Yank swore outrageously as he tried to skid the auto to safety. The jalopy hopped a fence, knifed between two trees, then slid into the canal. Phineas' means of locomotion fared little better. Its front wheel kissed the back of the jalopy and went out of line and Phineas went over the handle-bars, pancaked, and kept sliding. He made a big splash.

Phineas wondered if he had ridden that motorcycle all the way to the Channel as it did not seem possible a canal could be so deep. He lived fifteen years of his past life over again before he got his head above water. He crawled out of the canal, got into the shelter of an old shed, and draped himself over a barrel. Water drained out of his fuselage. He saw a frog hop into a clump of tall weeds and wondered if he had given that up too. Then he heard voices.

"Never mind that crazy louse," a man said. "He was drowned awright. I hope. Everybody here? Where's the aviator?"

Phineas had to get out of there toot-sweet. He lifted a haymaker to the brass hat's lullaby button and sent him reeling away!



The loaded stogie went up with a bang, and still more hunks of fabric stripped from the Gotha as its bombs were sent on their way.

"Here I am," a choking voice answered. "After what I went through in that D.H. gettin' them plates, they're in the canal. We'd have to git a navy diver here to find 'em. If I could get my hands on that crumb who rode that two-wheeled wagon, I'd take the meat off his bones in chunks an' then make a cannibal out of him. We manage to make a dead-stick landin' an' my gunner is out like a light from batting his dome against the Lewis. Four Fokkers chased us all the way from Germany an' now what have we got? It's safer in an airplane. Let me sit down."

Phineas Pinkham crawled around the corner of the shed and let the weeds hide him. He could see three very wet patriots huddled together and taking inventories of their respective anatomies. The flyer from Boonetown wished he had drowned when the import of what he had done sifted into his mental assembly.

"I will have to think fast to crawl out of this one," Phineas gulped. "They could shoot me for this. Them D.H. guys have been tryin' to get pictures of Kraut concentration near Diedenhofen for weeks and it looks like one camera clicker got them and there he is. Oh, what have I done? I will never do no more tricks. Well, I had better think up a swell story as they have got to prove it is a lie."

Phineas Pinkham waited for darkness to rule the land. Lady Luck smiled on him and she brought a night soaked with fog. Under cover of the gray blanket, Phineas managed to enter Bar-Le-Duc and sneak his way into a flat where his light of love, Babette, maintained her household.

"*Vous* are a fright," Babette said. "Eet has not been raining, *non? Mais vous* look—"

"Look, cherrie," Phineas said. "I am a desperate man. I go dans le closet there an' take off ze uniform, comprenny? *Vous* will press ze suit. Catch on pas?"

"*Oui*. What ees eet you get into zees time?"

"Never mind," Phineas said. "I was not canoein' on the Meuse. I have an hour to get back to the drome, so veet!"

Phineas arrived at the drome of the Ninth Pursuit Squadron at midnight. Major Rufus Garrity was sitting on the steps of the Frog farmhouse watching smoke curl out of two bomb craters out on the tarmac.

"The Krauts was here, huh?" Phineas grinned. "Was I lucky to be in town? Well, you should go inside and not catch cold—"

"Don't change the subject, you goggle-eyed mushhead. What happened in Bar-Le-Duc?"

"Oh, that? Did they make a fuss? Look, I was kiddin' with some officers and they couldn't get into the spirit of the thing. They were goin' to beat me up and I started running. I turned

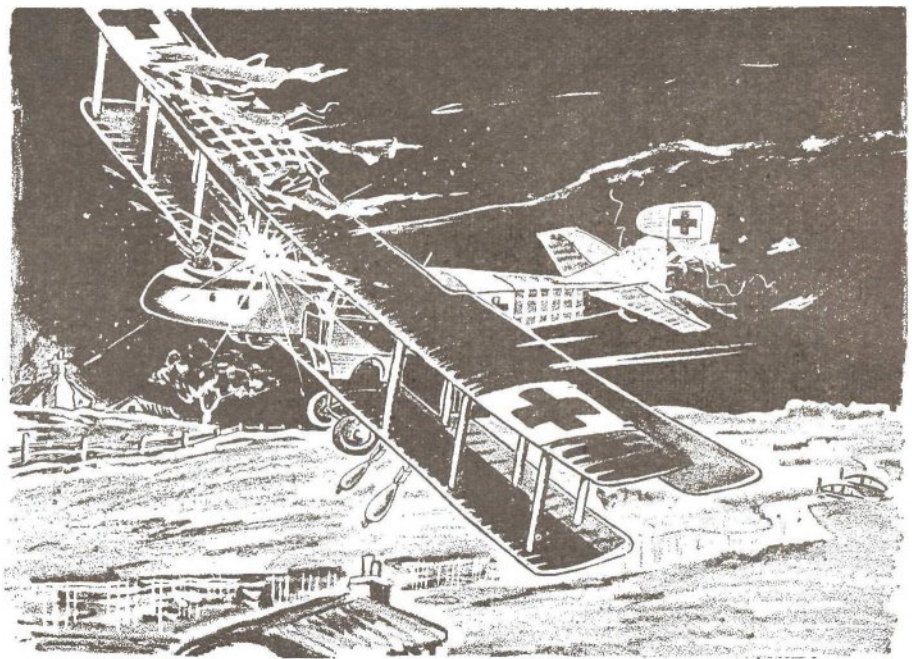

a corner and shook them off."

"What happened after you turned the corner?" Garrity roared as he got to his feet. He had a good-sized piece of a prop in his hand.

"Why, I ducked into a cellar and hid. When it was dark, I went out and called to see my girl," Phineas alibied.

"You didn't steal a motorcycle and then run it into a U.S. car carrying camera plates? You didn't fall into a canal?"

"Do I look like I've been swimmin'?" Phineas wanted to know. "Let us go in there where there is more light if you think—"

"Yes, let's," Garrity snapped and walked into the farmhouse. Captain Howell and Bump Gillis and eight other pilots were there, getting their nerves ironed out before they crawled back to their Nissans. Phineas gave them a flippant greeting for he felt as secure as a flea living on a tiger. Hadn't Babette even thought to rub his boots with tallow?

"Well, I bet you won't try that trick no more, Pinkham," Garrity grinned.

"Haw-w-w-w-w-w! You said somethin' then. I sure won't."

"No," Garrity yelled. "Because you haven't got another rubber omelet to your name. A guy found one on the ground near the wrecked motorcycle. He also picked up a couple of rubber cigars, a hand-shaking buzzer, and a bottle of flukey liver pills. You are under arrest! Go to your hut and stay there until the D.A. of the A.E.F. can get you a trial!"

"Wha-a-a-a?" Phineas yelped. "Why—I guess nobody is ever per-

fect. How did I know that jalopy was comin'?"

"Better put him under guard and find a mob-proof klink," Howell said sourly. "If D.H. pilots ever get their hands on him, wow! All they been through, all they've got to go through to get the pictures again! Phineas, you will never know another minute of security as long as you live. You will be haunted by the D.H. guys who might go West when they start out for them pictures again. It has been a long time comin' to you. This time you are cooked for keeps."

"If any of you bums was pals of mine, you would slip me a gun when nobody is lookin'," Phineas gulped. He strode to the Nissan with Bump Gillis and Bump said to him, "Remember, you are a prisoner and are on your honor, if any. I have a right to shoot you if you try and escape durin' the night. I hope you will try."

"Even you are against me," Phineas moaned. "What have I got to live for now?"

"Why did you ever have to?" Bump quipped. "Look, you have just about helped Germany win. They have found a way to make synthetic gasoline as the real stuff was petering out and they are concentrating it, storing most of it at a certain spot where it will be easy to ship to air-dromes. Well, the D.H. boys had the pictures of that place as one was color-blind and could see through camouflage. Maybe you will be executed."

"Leave me alone," Phineas sighed. "Isn't my cup of woe overflowin' now? You would feed salt fish to a guy you found dyin' on a desert. Well, I will take it like a man!"

When the Pride of the Ninth threw the oil at those Allied red tabs, they didn't know they were being gassed. But when Phineas tried to brew a Spanish omelet in a brass hat's favorite topper, he learned that safe set-down spots were—fuel and far between!

DAWN PATROL. One pilot only came out of the Pinkham-Gillis household. He did not bother to stop in the mess for coffee. He was a little late for the hop-off and he came running out of the hut with a knitted contraption over the lower part of his face. Bump's mother had sent it to her son not many weeks back.

"Sorry to disturb you, Vanderfeller," Captain Howell roared at the pilot as he climbed into a Spad. "We will stop at Nancy for crullers, huh?"

The props were turning and mechs and armorers were babbling so one voice was as good as another.

"I'm here, ain't I?" the pilot growled at his flight leader. "It is no skin off your stomach I didn't drink that varnish the U.S. calls coffee."

Captain Howell was needled by a strange feeling as he led his bunch upstairs. If he had been a woman he would have known it was intuition that was bothering him. He felt a presence that should not have been with him. The radiations of a certain personality were making him shiver. He suddenly smelled a rodent and twisted in his seat. Off to the right and not far behind him rocked Bump Gillis' Spad, but the pilot's face had a set of teeth that could furnish keys for a pair of Steinways. The pilot had removed his face warmer.

"That double-crosser!" Howell yelled and shook a fist at Phineas.

"They even condemn a guy for wanting to go out and atone for his crime," Phineas said as he lolled in his office. "Well I give my word but I didn't say positively. Haw-w-w-w-w-w-w!"

An orderly back on the field untied Bump Gillis and took the gag out of his mouth. Bump sought out Major Garrity and told of Phineas Pinkham's unprovoked assault upon his person.

"This is where I wash my hands off him. He might have had a chance in a court martial because I was beginning to feel sorry for him," the C.O. trumpeted. "I was even going to go to bat for him. But he is not to be trusted, Gillis."

"It amazes me," Bump spat. "I would never believe it!"

"He won't dare to come back," Garrity howled. "He will get killed this time. Ha-a-ah! And the U.S. government won't pay out ten thousand, either. Suicide don't count. Ha-a-a-a-ah!"

"Take it easy," Bump cautioned his superior. "You are not quite yourself an'—"

"I'd give ten thousand if I was sure I wasn't. Why did I ever join the Army?" the C.O. said, stamping around the Operations office as if the floor had caught fire. "We've got a swell Navy an'—Gillis, get out of here, you lop-eared bum!"

THE KAISER'S aerial artists were very much abroad this day. Twelve crates of a certain pesky von's circus started to roar down the Midway and the barkers were the Spandau guns mounted on their flying circus wagons. Captain Howell tried to get the sun behind him when the side-show started but a Fokker D-7 blocked his way and drove Krupp gravel through his top wing. But Phineas was higher up and he winged over and came down to start the scrap in the main tent. And when he poked the Jerry leader with two quick bursts, the ring master yelled a "Hey rube!" alarm and cried for his plug-uglies to take up where he was leaving off.

"A" Flight, Ninth Pursuit Squadron, had never seen Phineas in finer fettle. The Boonetown pilot, with nothing to lose but his future, turned in an exhibition of combat flying that never was taught at Issoudon.



"You stay wit us, ja," ordered the Heinie. "Kaput we will be if you try to egscap. Mach schnell!"

No Spad had ever been built to take what Phineas made Bump's crate take, yet the machine stayed together and flew with such abandon that addled Krauts were fooled into thinking that more Allied jobs had crashed the gate.

"Oh, so you got back in again, huh?" Phineas yelled as he saw the Kraut leader's black and green Fokker riding a Spad's tail. "Your seconds are no good as they should have never sent you out for another round." Phineas came up under the Boche Staffel leader and peppered his blind spot until it looked like a baker's sieve.

"Dusted his rompers with them tracers," Phineas said. "Haw-w-w-w-w-w-w!" He gave chase to the ring master, warming up his Vickers on the Fokker D-7's tail feathers. "I'll cut him down gradual until he is flyin' just with the wings and an engine. I've always tried to figure out

a crate without so much fuselage. I will see if one will work or why it won't."

Phineas found out that the Fokker could not stay upstairs with its tail assembly wiped off, to say nothing of the way its top wing was doing a strip act. The Boonetown trickster worried the von down to a thousand feet, then looked around to see where Howell and his mates were. The sky was devoid of Allied planes. There were twenty Jerries up there and they were all coming down to attend to one Yank. The D-7's were out. Those diving Dutchmen were sitting in Halbs.

Phineas kept going down to the carpet and he landed Bump's Spad on a stretch of pasture land that had a slope to it. The pilot from Boonetown crabbed downhill and ended up in a bosky dell, the fuselage of the Yank bus sandwiched between two trees. Phineas shook the cotton from

his brain and wormed himself out of the pit. He fell to a bed of soft pine needles just as Spandau lead spattered the real estate. The roar of props overhead nearly split Phineas' ear-drums and he wriggled into kind of cave that Nature had excavated in the side of a grassy bank. A bear chased him out and over a half mile of Boche territory before Phineas' breath gave out.

"That was runnin'," Phineas opined. "I passed a rabbit on the way. That bear saved me from bein' captured right away, I bet."

Two hundred yards away was a stretch of forest and Phineas reached it without falling over any of Hindenburg's patrols. He played Rip Van Winkle there until night came on once more, and then he emerged from the forest sore of foot and empty of stomach. He suddenly spotted a light and meandered toward it, caring little

whether it was occupied by Jerries or gorillas. It was an isolated, abandoned Alsatian farmhouse. Krauts had taken it over and Phineas could hear their gibberish coming out of a half-opened window. He got close to the window and peeked in.

Four squareheads were huddled around a table. One of them wore an officer's hat and the uniform of an ordinary Boche non-com. He had upper lip shrubbery that was very luxuriant and a pair of eyes that could haunt a house.

"On der map, *dumkopfs*, you see where ist going to be der fuel supply, *nein*? Easy to supply der tanks undt planes from such *ein* base, yah?"

"*Donnervetter!* Almost I think you belief it," another Heinie said. "Budt we must gedt back to der others. Two days now we forage for food undt ve eat all we find. *Der Herr*

(Continued on page 75)

WHETHER YOU handle the stick of a tiny sport job or sit behind the controls of a transcontinental airliner, every part of your ship was first born in the mind of some engineer-designer whose name you will probably never even hear.

It never occurred to the writer just how important these designers were until I happened to get myself into a technical chat with an engineer. He told me some interesting facts about the planning and building of the original Curtiss Hawk pursuit, powered with the D-12 Conqueror engine, and I recall him saying how the ship was calculated to hit a certain speed. To show you how closely these boys can figure, the plane was one mile per hour faster than they had expected.

Building speed into an aircraft is not the only job of the designer. He must arrange seating and baggage accommodations on airliners, the pilot's office, engine installation, and fuel systems. The windshields on

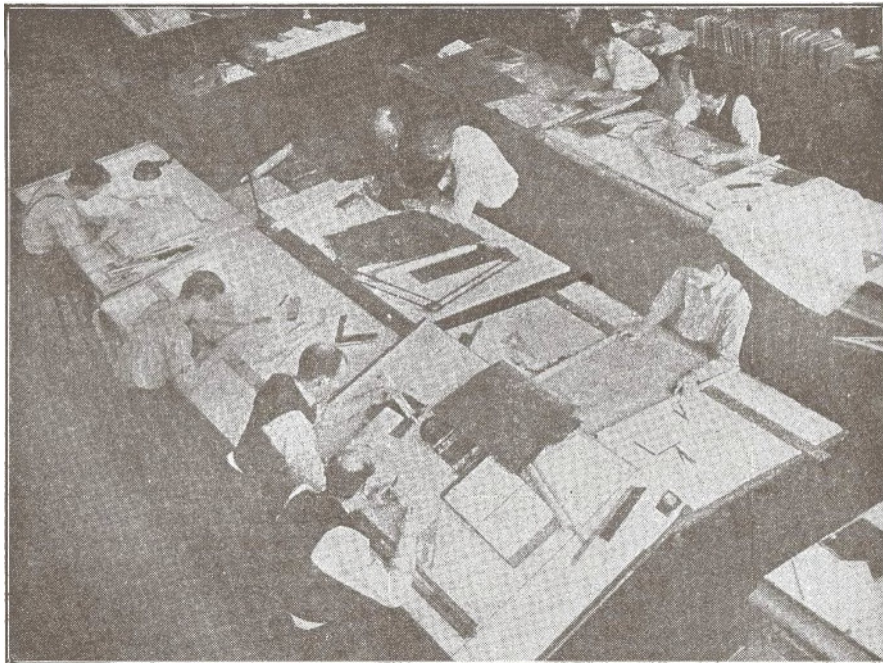

Just a few of the engineers and draftsmen who work for Curtiss-Wright.

DESIGN FOR FLYING

military jobs must withstand the power-dive, racks on Navy dive-bombers must be calculated for stress and practicability.

But don't think the designer's work stops there. It steps to the other extreme, and you learn that these engineers must tackle the seemingly unimportant tasks as well. They must tell the shop to countersink this hole, to overlap with the wing sheet metal at this-and-this spot, to use a 1/16" washer here and a lock washer there.

The ship is the thing, and aircraft designers are more in demand today than ever before. Not a single step can be taken in the manufacturing of modern aircraft until the designer is consulted. About the only other important individual is the backer, the man who is going to put up the money for the machinery, buildings, and personnel. Then, lo!—"Get me a couple of good engineers and designers."

SUPPOSE the company is going to turn out heavy bombers for the Air Corps. Well, the designer gives general specifications which should enable the machine to lift a specified load to a specified altitude at a specified speed. In level flight the ship must attain, let's say, 220 at cruising and 270 at wide open. Throughout the construction, the designer is consulted; you find him working in close relation with stress analysts, production foremen, draftsmen, and always you will find him keeping in close touch with the Army officers to learn how they are taking to suggested changes. From generalities to the most minute details, the designer is always around, since no

Most pilots don't realize how important engineers and designers are. They usually just take airplanes for granted and never think of the hours of toil and sweat that went into their making.

by Charles Yerchow

plane is ever built the way she is put on the blueprint. So many changes take place in the minds of those who have a say-so in the ship's building that this system just can't be eliminated. Pity the designer!

Around 1931 there was the interesting incident of the wealthy sportsman who hired a full staff and factory to build him a long-range cabin job, but he made the mistake of hiring, in addition to two American designers, one Frenchman and one Italian. Then, right from the start, there was friction in the truest sense of that word. The designers had their own pet theories as to how far a ship will fly with what kind of airfoil. They say the wings of that plane looked very uneven and everyone who saw the ship thought a couple of plumbers had built it.

ONE GROUP of engineers specializes in propeller design, and that reminds me of a fellow who planned his own prop, built it, stuck it on the front end of his OX-5. Then he toured Long Island in search of a backer. Mind you, he toured Long Island in an auto, not in the ship with the special prop. He was neither an engineer on props nor a very intelligent fellow, for even I could see that the blades of his invention couldn't hold together once the old OX kicked over.

But he did manage to round up some interested persons, among them the mayor and his wife from some nearby township. What's most important, though, he had a full-fledged engineer-designer on hand to witness the revolutionary development of his propeller. This designer took one short look at the wooden blades with copper tips and said, "I have to run home; remembered I left the gas on under the coffee."

You guessed it. That prop didn't hold together even for five revolutions. It disintegrated eagerly.

These cases, of course, are extremes, but they did occur. Regular designers, working for established aircraft manufacturers, receive their instructions on a generally pre-set idea. The factory then swings into production, keeping to the main purpose, and strives to build certain characteristics into a ship.

It is agreed that Uncle Sam has about the best plane designers in the world. American-built bombers and pursuits are being used by many foreign governments. American-built commercial planes, also, are found all over the world. Our sport planes, too, are the best and the most popular. All thanks due to the knowledge and ability of our engineer-designers.

THE END

Flying Aces Club News

News? That's one thing we've really got this month for you FAC's. But what's it all about? Well, you'll just have to dig in and let Clint tell you himself!

by *Clint Randall*

National Adjutant, Flying Aces Club

GREETINGS, CLUBSTERS! Zero temperatures around this part of the country during the past month must have been the reason for piles of mail coming into the NA's office daily. There's nothing like cold weather to keep a fellow at home to do the things he otherwise never seems to have time for. So when hundreds of Clubsters sit down with the same idea of writing letters—well, they just do and then your NA's got a hefty job to tackle. And the first missive we received this month came from Ross Smyth, 31 Wilfried Ave., of Toronto, Canada. Says Ross:

"The reason you haven't been receiving Club reports from us lately is because most of our members have found jobs in commercial aviation. However, we plan to get underway again in the Fall with renewed vigor.

"Clint, aviation has become more than a hobby with me—it is now my career. And to think it all started because I happened to pick up a copy of the June 1936 issue of FLYING ACES!

"Since last November I have been employed by Trans-Canada Air Lines, where my position is that of a dispatch clerk. Chief duties consist of supervising the distributional loading of all cargo, which includes handling the libroscope instrument. This gadget computes the gross weight and

center of gravity of the loaded aircraft. Among my duties are other little important details which must be attended to, all of which go to make the work very interesting. . . . And while I'm at it, Clint, I'd like to ask that members engaged in airline work—especially dispatch—correspond with me."

Good work, Ross! Nice to hear from you again. And here's a surprise: The points for this letter, added to your other Escadrille credits, brings your total up to the mark that merits you the Medal of Honor! You certainly deserve it for all the promotion work you've done in aviation; the Headquarters' Staff has unanimously agreed on that, too. Keep up the fine work, old fellow.

And now, while we're on the subject of medals, we come to this trip's special contest DSM winner. Our Master Model Builder of the Month is named Julia Morley and she lives in Lansing, Mich. Yes, Clint said "Julia" and "she"! This is the first time in the history of our contest that we've awarded the coveted Distinguished Service Medal to a lass, and we're all tickled pink about it. The DSM contest, you know, is open to all FAC's regardless of the color of their fingernails. And if the nimble, tinted fingers of Julia can turn out such swell work, then you male modelers better watch out! (This ought to encourage you other girls.)

Julia is a persistent girl and won't take no for an answer. Quite some time ago she mailed us pictures of her "Scotch Monoped" and asked that it be considered in the DSM contest. One look at the shots convinced the judges that, as far as

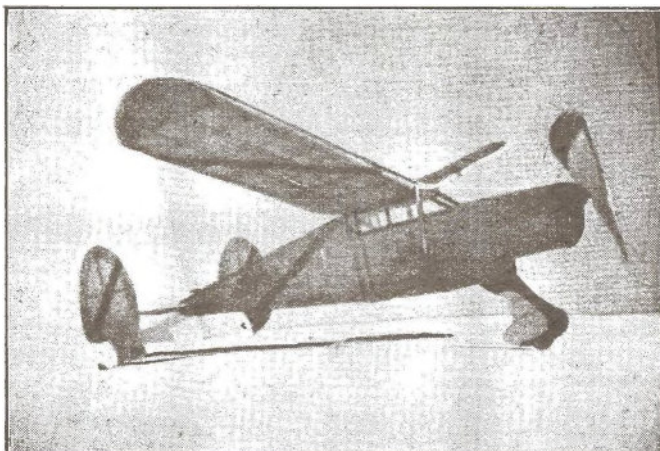

Winner of the Distinguished Service Medal this trip is Julia Morley, of Lansing, Mich. Her "Scotch Monoped" (December 1939 F.A.) was judged the best contribution of the month.



Meet young Paul McDermott, of Flushing, N. Y. He's the C.O. of a recently organized Flight.

photography was concerned, Julia was a sure bet for last prize—and so we sent her snaps back and suggested that she try again.

A few weeks later, sure enough, along came another group of photos. Those shots stood up under the eliminations, smashed through the semi-finals, and came out—the winner! So congratulations, Julia! GHQ knows you'll be as happy in receiving the DSM as we are in announcing you the lucky recipient. And as a favor, how's about sending us a snap of yourself wearing the medal? And for the rest of you Clubsters who haven't as yet entered our contest—we repeat still once again—all you've gotta do is—mail us a photo of a model built from F.A. plans. And if your picture proves you to be the top-notch builder of the month, we'll send you the handsome Distinguished Service Medal as your award. This is the last time we're going to give these directions, so you'd better remember them. Address all letters to Clint Randall, DSM Contest, FLYING ACES, 67 West 44th St., New York, N. Y.

We can't undertake to return photos submitted, and the decision of the judges—Wing Commander Dave Cooke, Model Editor Jesse Davidson, and National Adjutant Clint Randall—will be final. The picture of each month's winning craft will appear in our Club pages. Only FLYING ACES CLUB members will be allowed to participate.

HANDSOME Paul McDermott, of Flushing, N. Y., has recently organized an F.A. Flight. The group's "Club room" is temporarily located in the front porch of Paul's home. It is decorated with solid and flying models as well as pictures to give a real aviation atmosphere. As soon as the membership is increased, larger quarters will be established. Any fellows living within Paul's neighborhood are invited to join the Flight. Address letters to 57-17 134th St., Flushing. Here's a letter from Gerald Paul,



Attention Albert Einstein: Whether Gerald Paul is bending his knees in thanksgiving or trying to stop 'em from shaking—your guess is as good as ours. But here he is after his first lesson on the theory of space.

of Memphis, Tenn., who frankly states that in reading *FLYING ACES* for the past several years, he never bothered to see what the Club News was all about until he saw a photo of Don Marshall in the December, 1940 issue. Jerry says:

"I want to tell you that Don is not only the world's champ chute jumper but also the best instructor in the business and one swell guy. You see, Don instructed me on my first leap into space and I'll never forget it.

"It all happened back in my home town of Kennett, Mo., in the Fall of 1937, while I was taking flying lessons. I told the fellows at the airport that if I ever had the chance to jump, I'd jump at the chance. They laughed. Then, a couple of weeks later, Don flew into Kennett with a barnstorming outfit and heard that I wanted to hit the silk.

"Well, he sent for me and I had to stand pat on my claim. He instructed me in every way just what I was to do in the air. First, he sat me on top of an automobile and announced to the crowd that I was going to jump. Was I scared! Facing a crowd is no fun, let me tell you. So when he told me it was time to go up, I was darn glad. I climbed into the cockpit of a J-5 Eaglerock and Don handed me a horse shoe and wished me luck.

"We climbed to 2,000 feet and leveled off, and I was motioned to climb out on the wing. The pilot told me he would signal me when to 'meet the people.' The few moments I hung onto the side of the cockpit seemed like hours, and the ground looked like a hundred miles away. It's a lot different when you're in the cockpit and flying your own ship. But when you're out on a limb and some one else holds the stick, oh boy!

"Suddenly, the pilot yelled, and I let go and toppled over head first. Clint, there just aren't words to explain the feeling of falling through space, so I won't try.

"In a few seconds I felt a gentle shaking of my shoulders as the chute streamed out, followed by a loud bang! That is the greatest thrill in the world. Everything is suddenly quiet and peaceful save for a gentle slap of the chute in the wind. It doesn't seem as if you're moving—just floating. Then you realize the ground is getting nearer and it's coming up fast.

"I remembered Don's instructions and relaxed. I hit in a sitting down position and then tumbled over backwards. I jumped up, yelling and dancing. Wow! I had done it! Since then I've had many thrills. But thanks to Don Marshall for the greatest thrill of a lifetime."

Whew! You might have made that jump, Jerry, but your graphic illustration of the experience had us riding that silk down with you!

WE HAVE some new additions to the roster of Honorary Club Members who are as follows: Governor Herbert R. O'Connor of Maryland, Mayor Howard W. Jackson of Baltimore, and Commissioner of Motor Vehicles W. Lee Elgin. These men were signed up as H.M.'s through the efforts of Col. Robert G. Cooper, of the Maryland Squadron, No. 1, with headquarters at Baltimore. Col. Cooper states that he would like to have all young men in that city who would like to join his Squadron to contact him at 2241 Kirk Ave.

Another Honorary Member is Jack Frye, President of TWA, who was signed up through the efforts of Kathleen McGee, of Dayton, Ohio. Kathleen is all wrapped up in aviation and her deeds are noteworthy. In her letter to the NA she told how her interest led her to take a course in aeronautics, and how, not so long ago, she was presented with a Sperry compass which she can now disassemble and explain clearly its mechanisms and the part they play in relation to the airplane.

Some time ago she presented the children of the Whitmore Home, of the Miami Valley Hospital, with twenty-five dollars worth of model kits and supplies.

Most of the boys she spoke with have plenty of faith that they will soon be able to walk and follow their desire to

It's a far cry from the days when Glenn L. Martin built and flew the kind of ship which he fondly recalls by examining its scale prototype. This recent photo was sent to us when Mr. Martin accepted an Honorary Membership to the Flying Aces Club.

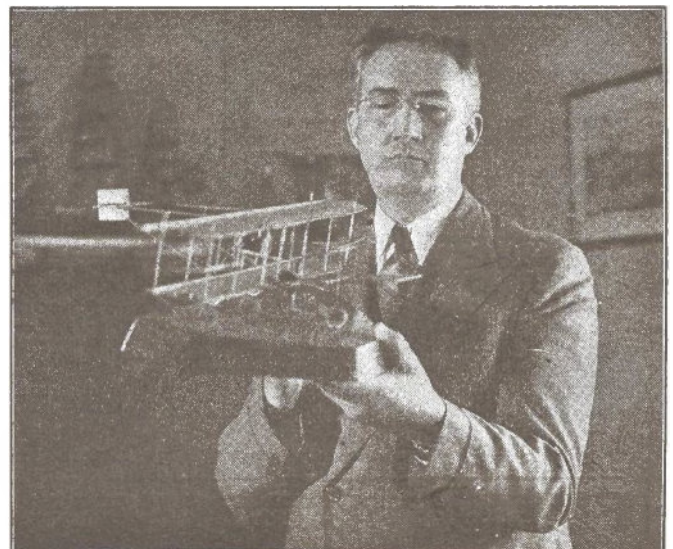

become pilots. Also, Kathleen has presented many of her model planes to a professor of chemistry who is using them for display purposes. Her proudest moment, though, was when she received an RAF brooch from Lancashire, England.

Clint wishes to commend both Kathleen McGee and Bob Cooper for the fine work they've been doing. But this is more than just a "congratulations," for we're awarding Kathleen a DSM for her outstanding services. And Bob, you keep going as you are, and soon a swell medal will be in the mail for you.

HERE'S A NOTE from Private H. J. Backowski, who says: "Clint, I'd like very much to correspond with a young fellow about 18 to 19 who knows his stuff about real planes as well as models. I'm attached to the 5th School Squadron, BKS 434, Chanute Field, Rantoul, Ill., and can surely tell him of the many interesting things that go on around here."

Personal to Charlie Ogg: If you have already won the DSM you cannot compete for another medal. However, if your photo is judged best, you will receive a citation to add to your medal's ribbon.

This citation is known as a "bar" and is the shape of a propeller. It means simply that instead of weighing one's chest down with the same type medal, the bar denotes that the wearer has been awarded another recognition.

Latest members to be enrolled in the Escadrille at the time of closing this issue are: Cleave McWillis, Puyallup, Wash.; Harry Reheard, Florin, Pa.; Eddie Lastowski, Newburgh, N. Y.; John Killian, Perryville, Mo.; Fred Staudaker, Bozeman, Mont.; Eugene Sobolewski, Freeport, Pa.; Robert Hid, Willmar, Minn.; Stanley Buettner, Alameda, Calif.; Buddy Cook, Los Angeles, Calif.; Everett Weniger, Kevin, Mont.; and Jay Macy, New York City.

That's all, Clubsters. More next month.

THE END

JOIN THE FLYING ACES CLUB

Honorary Members

President and Mrs. Franklin D. Roosevelt	ex-Vice Pres. John Nance Garner
Casey Jones	Rear-Admiral Byrd
Wallace Beery	Col. Eddie Rickenbacker
Al Williams	Colonel W. A. Bishop
Col. Scaroni	Major G. A. Vaughn, Jr.
Major von Schleich	Willy Coppens
Lieut.-Col. Pinsard	Glenn L. Martin
G. M. Bellanca	Walter H. Beech
Capt. B. Sergievsky	Zack Mosley
John K. Northrop	Dwane L. Wallace
Colonel Roscoe Turner	Josef Veltjens
Charles W. A. Scott	Col. A. P. de Seversky
Richard C. DuPont	Donald W. Douglas
Mal. A. W. Stevens	Major C. C. Moseley
Capt. O. A. Anderson	Clarence D. Chamberlin
Major Fred Lord	Mrs. Charles S. Baylus
	Lieut.-Col. Theodore Roosevelt

Do Your Full Share to Advance Aviation

To advance the cause of aviation, over 50,000 men and women, boys and girls, have banded together to form the FLYING ACES CLUB.

It is the easiest club in the world to join. Just clip the membership coupon, fill out, and mail it to GHQ with a stamped, self-addressed envelope. Your official card will then be forwarded to you. After joining, you can quickly win promotion and the right to wear the various insignia of the Club.

In the FLYING ACES CLUB there are two kinds of local organizations, known respectively as Squadrons and Flights. A Squadron must have eighteen members, including its leader. A Flight must have a total of six. You can start either of these groups in your own community by enrolling your friends in the Club, then applying for an official charter as detailed in the column at the left. *Each member must hold an F.A.C. card.*

Meetings and activities are conducted among the squadrons and flights according to the wishes of the members. GHQ has established no rulings in this respect, nor are there any dues or red tape whatsoever. The entire idea of the Club is a common meeting ground in an international organization for the lovers of aviation in its various phases. Many local Squadrons and Flights hold regular contests and public events. Many hold weekly meetings for model building, and instruction, and even regular flight training.

Awards and the Aces Escadrille

After the membership card, and Cadet and Pilot's wings, comes the Ace's Star. This is awarded for enrolling five new members, using, of course, a separate coupon for each. As an Ace, you are then eligible for membership in the FLYING ACES ESCADRILLE. Then you may win truly handsome awards. Among these are the Distinguished Service Medal and the Medal of Honor, two of the finest decorations that have ever been designed.

Any member who has reached the rank of Ace is eligible for membership in the FLYING ACES ESCADRILLE, an advanced organization which replaces the old G-2 unit and opens the way for participation in a definite program contributing to the forward movement of aviation.

To enroll, an Ace must apply direct to Escadrille Headquarters, giving his name, age, address, rank, and highest award already won in the Club, and enclosing a stamped, addressed return envelope. If he is approved for membership his instructions will be forwarded. Membership in the Escadrille is limited to American and Canadian members only, at present.

Keepers of the Log

In order to keep in touch with GHQ, every squadron should appoint a member with a facility for writing as Keeper of the Log. It shall be the duty of the Keeper of the Log to send in regular reports of interesting doings of his squadron. His is an important job, because it is only by means of interesting squadron reports that life can be given to the Flying Aces Club News.

Photographs, too, are an important consideration for the Keeper of the Log. Either the Keeper himself, or any other member with a camera, should keep a photographic record of the squadron's activities, for reference purposes, to show prospective new members, and to allow a selection of pictures to be sent to GHQ for reproduction in our monthly Club News pages.

The cost of film, prints, etc., would be a legitimate charge against the squadron's own treasury or could be covered by members' contributions. A number of flights and squadrons, incidentally, send us prints which have been taken, and completely developed and printed by foto-fan members of the outfit.

Correspondence

In all correspondence with GHQ where a reply is desired, enclose a stamped, self-addressed return envelope with your letter. GHQ receives thousands of letters weekly, and cannot undertake to answer those who do not heed this rule.

Official Supplies

Due to popular request, we have ordered a new supply of F.A.C. paper pennants. These attractive stickers, which have glue on the back so that they may be stuck onto car windows, etc., sell at 6 for 10c, or 20 for 25c.

We also have a new supply of well embroidered wing insignia that'll look top-notch on your sweater. They're made of the official Flying Aces Club colors, blue and gold, and are available at 25c each. Order now before the supply is exhausted.

Overseas prices: Pennants, 20 for 2/-; wing insignia, 1/6.)

Official Charters

F.A.C. Flights and Squadrons are recognized at GHQ only after they have received their official charters. These illustrated documents, printed on fine paper and portraying various features in the field of aviation, are excellent for framing and display. Their inspirational text is in keeping with the high ideals and aims of our Club. Each charter application must include a full list of proposed group members and their addresses. Each of these members must hold his regular F.A.C. card, obtained by clipping and sending in the membership coupon printed on this page. If applications are approved, Flight Charters are issued for 25c, and Squadron Charters for 50c. Send the correct fee with your application: It will be returned if the Charter is not granted.

WIN YOUR WINGS

Save This Whole Coupon for CADET OR PILOT insignia of the F.A.C.

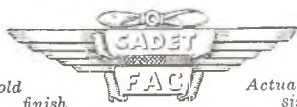

Gold finish Actual size

All members with Official Membership Cards are eligible for Cadet Wings. This coupon, with two others and 10c, entitles members to Cadet Wings. Do not send this coupon alone. Save it until you have three. Then send them in all together with a self-addressed envelope and 10c to cover cost of wrapping and mailing.



Silver finish Actual size

All enrolled members who have won their Cadet Wings are eligible for Pilot's Wings. This coupon, with four others and 10c, entitles Cadets to Pilot's Wings. Do not send this coupon alone. Save it until you have five. Then send them all together with a self-addressed envelope and 10c to cover cost of mailing.

Send the Whole Coupon

regardless of which kind of wings you wish. Separate sets of coupons are needed for each insignia. Canadians send 15c, or three International Reply Coupons. Overseas readers send 1/-, or five Reply Coupons secured at the Post Office. Only one pair of either kind of wings to a member. If yours are lost, send 25c for new ones (2/-overseas). [51]

For a Limited Time



Beautiful STERLING SILVER

F. A. C. Ring

ONLY 50c

We have on hand not more than one hundred official F.A.C. rings which are being sold, while they last, for 50 cents apiece. This beautiful STERLING silver ring is self-adjustable to assure a perfect fit. Formerly offered at \$1 apiece, the rings will be shipped post-paid anywhere in the U. S. and possessions to those whose requests arrive first. Take advantage of this excellent offer now. As a loyal Clubster you'll be proud to own one!

May Membership Application

I, the undersigned, hereby make application for membership in the Flying Aces Club. I agree to live up to its rules and regulations; to foster the growth and development of aviation; and cooperate with all other members in the work of spreading aviation information, building up confidence in flying for national defence and transportation. I will aim to build up the Club and its membership, and do my best to win the honors that the Flying Aces Club offers.

My name is
Age [51]
Street
City State

Do you build airplane models?.....
Mail this application, enclosing a self-addressed, stamped envelope. Canadian and overseas readers send the application, self-addressed envelope, and an International Reply Coupon worth 5c, secured at the Post Office.

FLYING ACES CLUB, 67 W. 44th St., New York

All Questions Answered

This section of FLYING ACES is at your service. So if you have an aero query, fire away and we'll answer it here. All questions will be considered in the order they are received. For a personal reply, send stamped, self-addressed envelope.

Earl E. Tanguay, Neenah, Wis.:—Amelia Earhart was the first woman to make a solo flight across the Atlantic.

Edward Dixon, Ridgewood, N.Y.:—The Armstrong-Whitworth Siskin is very obsolete and I doubt whether you could find one in Canada today. Yes, mufflers usually cause a certain amount of back-pressure and lower the produced horse power. The Grumman F3F-2, with a Cyclone engine, is said to do 270 m.p.h. The F2F-1, with the Twin-Wasp, Jr., will do 237 at 7,500 feet.

Edward A. Hood, Brooklyn, N.Y.:—We cannot send out photographs to our readers. In most cases—and definitely in the ones you mentioned, since they are so scarce—we must keep the original shots for our files. Sorry we can't help you on this.

Bob Wittig, Paterson, N.J.:—I'm afraid we'll have to disagree with you on that dead-stick landing idea. You can't say definitely that the prop always continues to turn. Remember, "dead-stick" means that the airscrew has no power behind it. And if the forward speed isn't enough to overcome the engine compression, then the prop will not revolve. Our editor, David C. Cooke, by the way, previewed "Young America Flies."

Paul Ode, White Bear, Minn.:—You asked if we ever published plans for the Moraine-Saulnier 406, the Focke-Wulf 198, the Defiant, the Messerschmitt Me.109, and the Spitfire. We have not presented the M-S 406, but we did show the 405C1 in the March 1940 issue. The Defiant and Messerschmitt were not used; see the April 1937 issue for the Spitfire. We intend to publish those other plans in the near future.

Jack Clowes, Great Neck, N.Y.:—We cannot supply you with the original drawings of "They Had What It Takes," since they are kept in our files.

Ernest Soehren, Jersey City, N. J.:—Sorry, but the information you request is still secret. However, if you write directly to Martin, perhaps they will help you.

Sam Gurmusa, Ambridge, Pa.:—Thanks for your comments on the mag. We're doing everything we can, you may be sure, to make it better than ever before. As to that question

on the Nieuport, both engines were used at various times. The Le Rhone, however, was installed almost universally in the later models.

J. Bailey, Providence, R. I.:—A good background for any prospective aero vocation would include mathematics and all the science you can get. This applies not only to pilots but mechanics as well. We're glad to see that you're interested in the mechanical side, too, for entirely too many young fellows want to be nothing but pilots—and they come a dime-a-dozen.

Kendall Shaner, Barlington, N. D.:—Yes, some military-type airplanes may be bought commercially. The Ryan trainers, the Fairchild trainers, the Curtiss 21 interceptor, and many others may be easily purchased—if you've got the money. Figures on the Ryan PT-20 are: top speed, 150 m.p.h.; cruising speed, 127 m.p.h.; landing speed, 42 m.p.h.; initial rate of climb, 1,200 feet per minute; absolute ceiling, 21,200 feet. The ship is powered by a Menasco engine of 125 h.p.

Jackie Flood, Brooklyn, N. Y.:—Ray Collishaw is officially credited with 68 victories, and Major John T. Hawker had 27. I don't know if this is the Hawker to which you refer, however, since you didn't give the first name. The Fairey Battle is powered with a Rolls-Royce Merlin liquid-cooled engine of 1,030 h.p. and has a top speed of 257 m.p.h. No, the Airacobra cannot do 600 m.p.h.—unless while diving.

Samuel Schwartz, Champaign, Ill.:—Your particular list of questions would require considerable time and space to answer. We feel that in our Light Plane Tarmac department we have given plenty of detailed reports on the various types of light planes. To transform, as you put it, any modern sport or commercial plane into a military job simply cannot be done if any degree of flight efficiency is expected.

Max Nelson, Carrier, Okla.:—The "G" in dive-speed terms refers to Gravity. In other words a 9-G pull-out exerts nine times the strain of ordinary gravity on a plane. The difference in painted engine cowlings you refer to is because Navy squadrons are divided into different elements and the colors on the cowlings identify the various planes in each element. The plane Wiley Post was

flying was of no particular type. I believe it had the fuselage of one of the Northrop ships and the wings of another.

Morton Karp, New York City:—Sorry, but we cannot make suggestions about flying or vocational schools. If a school has a Government certificate, that should be enough. You had better look over the list in FLYING ACES or other magazines that carry flying school advertising.

Richard Yates, Klameth Falls, Ore.:—We carried full details on the Airacobra and the Airabonita some months ago. The Airabonita is a naval carrier version of the Airacobra. It is stressed for deck landings and carries considerable naval equipment. It also has a normal two-wheel undercarriage. Otherwise, it is practically the same plane.

Jerry Staffney, Pittsburgh, Pa.:—Our model editor states that the planes you asked about are in the Class "C" division.

Leon Kershaw, Duluth, Minn.:—I do not believe you could obtain and fly a plane that was armed, even though you were carrying a valuable payroll. You might get such a permit in Mexico, Alaska, or Canada under unusual conditions. I do not know whether you could buy old World War planes and I do not believe you could get a license to fly one.

Robert Quick, West Camp, N. Y.:—You can buy Jane's *All the World's Aircraft* at any good bookstore.

Robert Quick, West Camp, N. Y.:—Your drawings and ideas are okay with me, but of course anything as unusual as that requires more detail and construction facts before one could say whether it would fly or not. Still, keep up the good work. You may hit on something later on.

Bob Mantell, Washington, D. C.:—I was on dozens of World War aerodromes and no two were alike. They put up the hangars where they could and made the best of whatever landing ground they could get. They usually consisted of three Bessemer huts, a few wooden huts, an Orderly Room, Men's and Officers' Mess, Armorer's shed, cookhouse, gun test pit, petrol dump, and bomb store.

THE END

With the Model Builders



Before enlisting in the army, James Bauer, of New York City, gives his kid sister Helen a couple of pointers on building solid scales. The ship they're holding is a quarter-inch scale Boeing F4B-4.

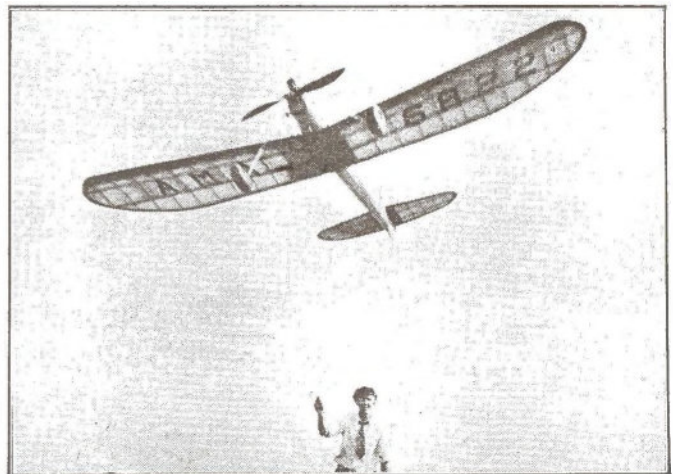

Gliding nose high near the ground is most always fatal to a gas job, but Walter Stobie's none too gentle heave gives the ship plenty forward speed to come out of it. Not a bad looker, is it?



Morris Mountjoy, of Hyattsville, Md., fastens the lock pins to hold the wings of his Brown-powered Waco. Wing panels are designed to shear off upon impact without injuring rest of the structure.



The fact that this S.E.5 is so small isn't at all amazing. Human hair is used for guy wires!

Who said models have no personality? Sal Taibi is a big husky fellow. Look at his gassy. And gaunt Hank Struck strikes a pose quite similar to the design of his ship. Just a couple of champs.



Here's an interesting looking job. It was designed by the Thelphsen brothers, of Loch Raven, Md., and was first flown at a city meet. The ship is Brown-powered, fast, and an extremely stable flyer.



Spitfire - 2

CHARACTERISTICS	
... MAIN DATA ...	
WING AREA	242 SQ. FT.
FUEL	85 (IMP) GAL.
OIL	5.5 (IMP) GAL.
TOP SPEED	397 MPH AT 18,500
... ENGINE DATA ...	
TYPE	ROLLS ROYCE MERLIN
MAX. ENG. LENGTH	73.53"
H.P.	1250 H.P. ON 100 OCTANE
No. of CYL.	12

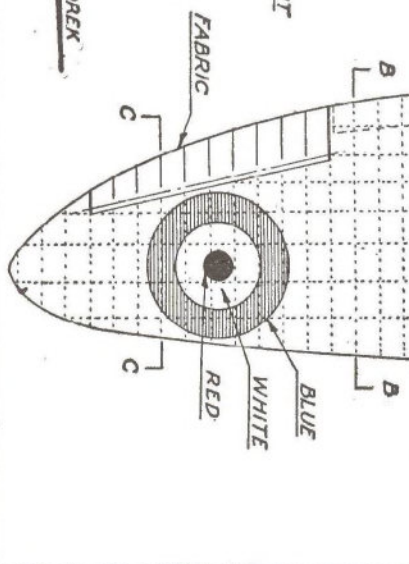
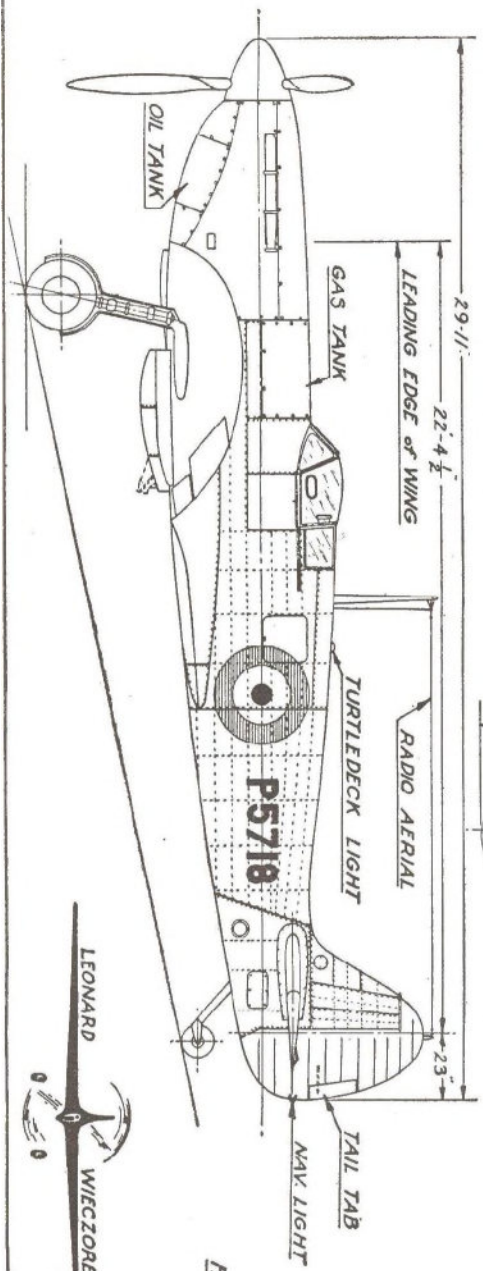
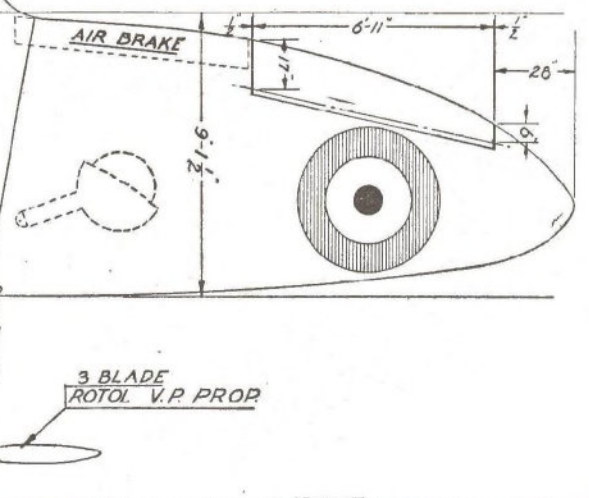
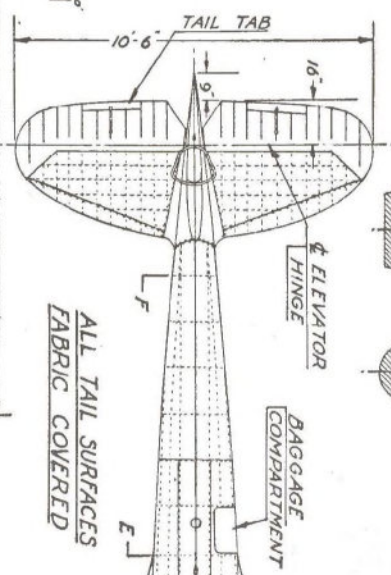
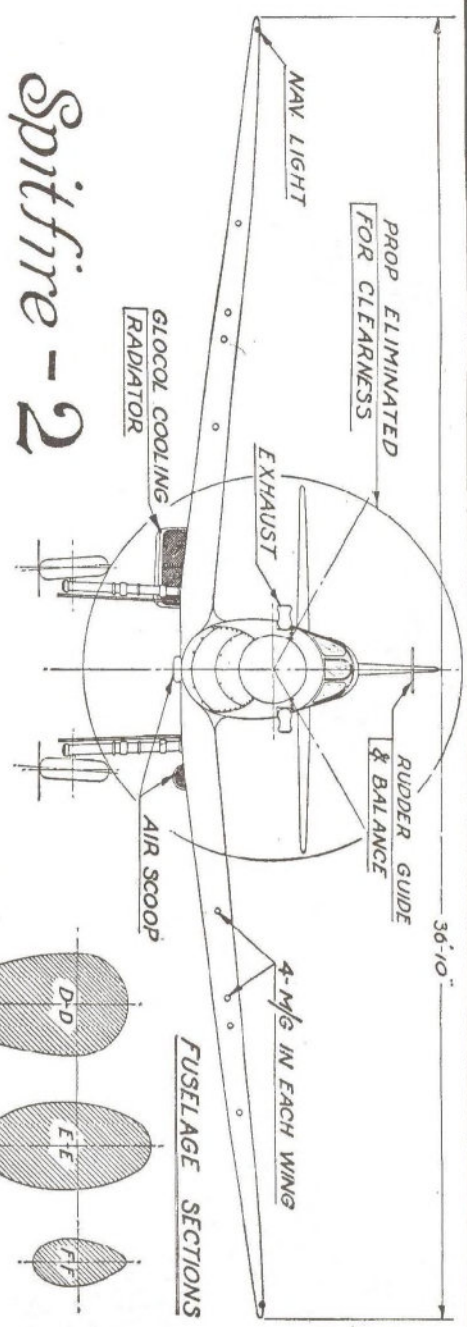
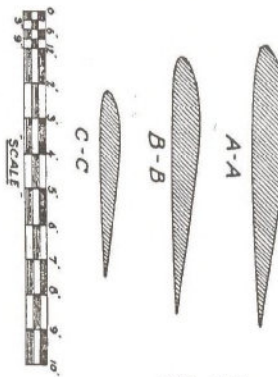

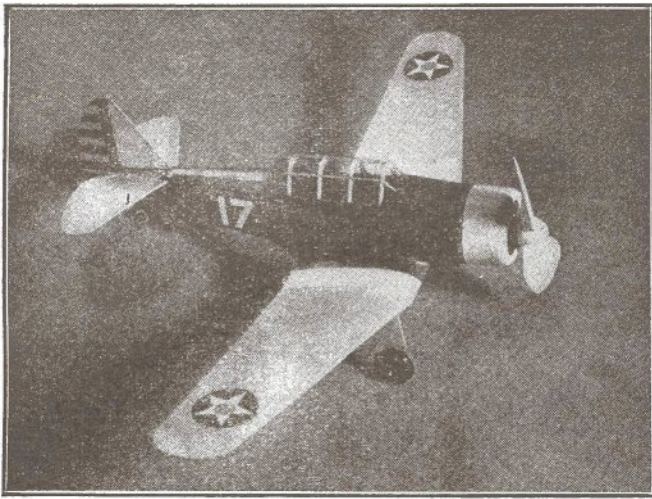

A perfect example of craftsmanship. It flies as well as it looks.

ARMY BC-1

Follow these plans and instructions for building one of the most realistic scale models ever designed to fly.

by Milton Kahn

DEVOTEES of flying scale jobs haven't a very wide selection these days since most of our planes are either mid-wingers or low-wingers. On top of that, the majority are military types.

Some sort of a bugaboo still exists, however, that low-wing flying scales are not so hot, and as a result are more or less treated like a stepchild. Nonsense! That's all this author has been building and flying for the last three years, and he can report nothing but excellent flights with swell flying characteristics to boot—including this month's job.

The North American trainer in Air Corps circles is known as the BC-1 basic combat. The manufacturer's designation is NA-16-3. This two-place ship is widely used in preparing Flying Cadets to eventually handle swift, single-seat fighters. This "prep school" ship is a tricky job, and has to be flown every minute. The BC-1 is powered with a 550-h.p. Pratt & Whitney Wasp engine and cruises at 195 m.p.h. It has a maximum speed of 210 and a rate of climb of 1500 feet per minute. Landing speed with flaps is 67 m.p.h. and cruising range is 900 miles. Structure is all-metal throughout and tail surfaces are stressed-skin covered while moving parts are fabric faced.

FUSELAGE CONSTRUCTION

EASIEST WAY to start things right is to remove Plates 1 and 2 from the magazine and pin down to a flat surface. Over these pages, spread a convenient sized sheet of wax paper. The necessity of this will be obvious. Your first step is to cut to correct size the four longerons and pin them into position on the side view. The longerons are identified by the dotted longitudinal lines.

Cement the uprights (also called compression members) in position. After one frame is completed, lay down the second side and in due time remove so that both sides can be attached by cross braces. The cross members are cemented at right angles to each upright. An illustration is best given on Plate 1 showing a front

view of the frame with formers around it.

Crack the frame slightly at the point where former F-3 is to be mounted. Taper the nose so that F-1 can be cemented as shown in the top view. The remaining three formers (also parts of F-1) required to round off the nose is shown in full size front view on Plate 1. The side formers are notched for a single side stringer, top and bottom formers, for three stringers.

Formers, F-4 to -7 inclusive, are cemented as shown, while on the bottom, formers F-8 and 9 (formers and wing spars combined) to F-13 are cemented in position. Later, F-2 formers are attached on each side of the body. After this is secured, fit in the 1/16" by 3/32" stringer as shown and taper as noted on Plate 2. Up front, this stringer is cracked slightly and cemented at the angle shown between the nose bulkhead and F-2.

Wing fillet parts WF-1, of which two are required, are cut to shape and attached after the leading edges of the stub wing are cemented into position. Rear wing fillet WF-2 is likewise attached when ready.

The cockpit hatch is strengthened by cementing in the stringers where required. The curved rear part of the stringers are cut to the necessary shape from 1/16" sheet. Stringers required for the top and bottom formers are attached next. Omit the center stringer for the bottom formers until the entire wing has been built and cemented in position. Study your plans so that this is made entirely clear to you before covering the model.

WING AND TAIL BEFORE MAKING right and left wing panels,

the center section or stub wing, must be built into the fuselage. Since formers F-8 and -9 are already cemented in place, attach wing ribs R-1 and 2 into the notches provided for them. Next fit into their leading edge slots, the leading spar. The trailing edge spar is tapered as required and also glued. Curved sections forming fillets WF-1 and -2 are next to be cemented.

Wing construction is conventional and simple. Shape the designated ribs and cut the notches out carefully. Pin down the wing spars directly over the wax paper covered plans and cement each rib as noted. Add the leading edge spar, followed by the trailing spar which should be tapered to conform correctly. The tips are added on last. Cement all joints well and later sand down the rough spots. The second half of the wing may be made by reversing the plan. Beforehand, however, go over the outlines with a pencil so that the impression shows clearly through the reverse side.

Ribs, spars, and leading edge of both the rudder and elevator are cut to correct lengths from 1/16" sq. hard balsa. The curved edges are trimmed to shape from 1/16" sheet. Apply cement liberally on all the connecting parts.

The rear hook is shaped from No.

Sturdy construction throughout enables the craft to stand up well.

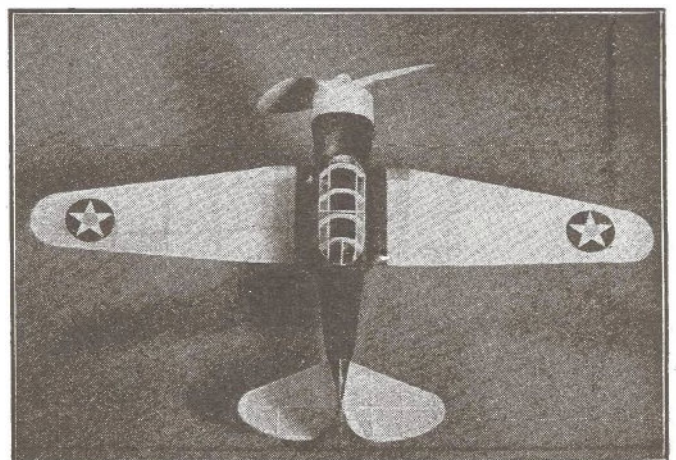

12 piano wire, inserted into the tail post as shown, and bent to shape and cemented. The tail wheel fork is made likewise and cemented securely. At this time, metal fittings for the landing gear and prop shaft may be shaped from wire of the same gauge.

COWLING AND LANDING GEAR

THE FRONT edge of the cowling is sanded to shape from a disc of required proportions. Use a compass to obtain the correct diameter and trim with a sharp razor. Make an opening in dead center for the removable nose plug. A slight recess is sanded in about 1/16" deep as indicated by the dotted lines in the side view of the cowling.

To attach the frontispiece of the cowling, first lay it flat on its face. Then cement four pieces of balsa each measuring 1/8" by 1/8" by 11/16" upright at quarterly intervals. After they have hardened in this position, take the whole unit, and cement it flush against the open-faced nose. When this dries, the cowling sides are covered with 1/32" sheet. However, first round off the 1/8" square mounts with sanding. Use model-making pins to aid in holding the sheet covering until the cement hardens sufficiently to warrant their removal.

The landing gear legs are made from hard balsa dowels a single length and then sanded and cut to shape. The front view plan of this unit is shown on Plate 1. After the leg is shaped, take a perfectly straight length of wire and carefully insert it through dead center of the strut all the way down until enough of it comes through the bottom to be bent outward for the axle. Apply a dab of cement on top and bottom ends.

The outer flaps are cut to the required pattern from 1/6" sheet. This is shown in full size on Plate 1. Flatten the outside of the upper part of the landing strut slightly so that when the flap is cemented it may adhere more easily.

When both landing gear legs are ready, attach them with a liberal amount of cement as indicated by the positions shown in top and side views.

PROPELLER AND COVERING

CARVE THE propeller from a hard balsa block measuring 1" by 1-1/2" by 7". By using slightly larger wheels the diameter may be increased. Enlarge the pattern shown on Plate 3 in order to obtain the full size blade. The spinner cap is carved integral with the prop. Cup the inner sides of the blades for greater efficiency. Insert the wire shaft as required, slip through the nose plug and bend to

shape. Balance the blades perfectly.

Covering the ship must be done in an expert manner in order to bring out the best looks for this craft.

Start with the tail parts. Use yellow Japanese tissue as in this case it is the standard color for a military plane. Apply the dope lightly along the leading edge of the elevator from one end to the other. Lay on the paper and smooth out the wrinkles. When the liquid dries, apply the dope more generously to the ribs, center spar and trailing edge. Fold the paper over these parts and pull tightly.

The outer edges are then trimmed leaving a 1/8" margin. This is doped and folded in all around the edges. The uncovered side is treated likewise and trimmed. The rudder is

be doped with banana liquid as they will warp completely out of shape.

The wing panels are also covered with yellow tissue. First cut out a pattern of the outlines, leaving a quarter inch margin all around. Apply the dope over the front edges of the ribs and flatten the paper to them. As soon as the liquid dries, extend applications of dope down to the trailing edges and smooth the paper right over it. Then the leading and trailing edges are tacked down and the tips trimmed. The top part of the wing is covered in the same manner.

When both panels are completed, shrink the tissue by water spraying both sides of each wing. After that, apply at least two coats of dope. Regulation colored stars are attached to

the top and bottom surfaces as shown in the wing plan view on Plate 3. The letters spelling out U. S. ARMY should be trimmed out of black paper and mounted in the correct manner. The flight photograph illustrates this best.

Before covering the fuselage, install the rubber power and hook on the washers and propeller.

The fuselage is covered in sections. First the sides, then the rounded top, and lastly the bottom. Blue paper is used throughout for the body, including the fillet section extending from the side of the body

out to the first rib of the stub wing. The space between that rib and the outer rib of the stub is covered with yellow paper. The cowling may be covered with blue paper if desired. It may, however, require more than one covering in order to darken the lighter colored sheet balsa.

The cockpit hatch is covered with either isinglass or thin sheet celluloid. Trim the rudder with regulation red, white, and blue stripes. A sheet of such tri-colors may be purchased at any model supply shop.

ASSEMBLY AND FLYING

AT TACH THE wing panels to the stubs with plenty of cement. Place object at the extreme tips of the wings so that the dihedral angle measuring 1-1/4" will be obtained. Insert small model-making pins between the first wing rib and the stub wing rib to aid in holding this angle. Later remove the pins and fill up the holes with small dabs of cement.

The stabilizer is slipped into position and cemented fast. The rudder is mounted next. Be sure that these surfaces line up at right angles to one another.

As the ship stands, it is a bit tail heavy and therefore requires additional weight to the nose. This can

(Continued on page 80)

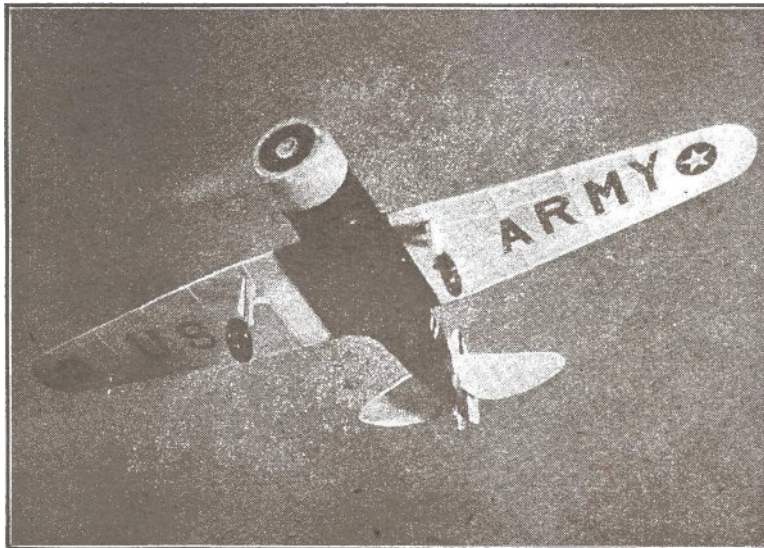

Graceful lines and beauty of flight are captured by this excellent take-off shot.

covered with yellow tissue and after this is completed, both surfaces are sprayed lightly with water and set aside to dry. These surfaces must not

BILL OF MATERIALS

(All wood medium balsa)

- Ten pieces 1/16" sq. for longerons, cross braces, stringers, etc.
- Two pieces 1/16" by 1/8" by 8" for front wing spar
- Two pieces 1/16" by 1/16" by 8" for rear wing spar
- Two pieces 1/16" by 1/8" by 12" for the leading edge and wing tips
- Two pieces 1/16" by 1/8" by 12" for the trailing edge
- One piece 1/4" by 14" by 2" for the cowling nose piece
- One piece 1/6" by 3" by 36" for ribs, bulkheads, tail parts, etc.
- One piece 1/32" by 3" by 6" for motor cowling cover
- One piece 1/4" by 1/4" by 6" for landing gear strut
- One pair of rubber or celluloid wheels 1 1/8" diameter
- One nose plug to fit
- One piece of piano wire No. 12, eight inches long
- One piece 1" by 1 1/2" by 7" for propeller
- Paper—yellow for wings and tail, blue for fuselage, tail wheel, washers, cement, dope, isinglass or celluloid, sandpaper, razor, knife, and four feet of 1/8" flat rubber

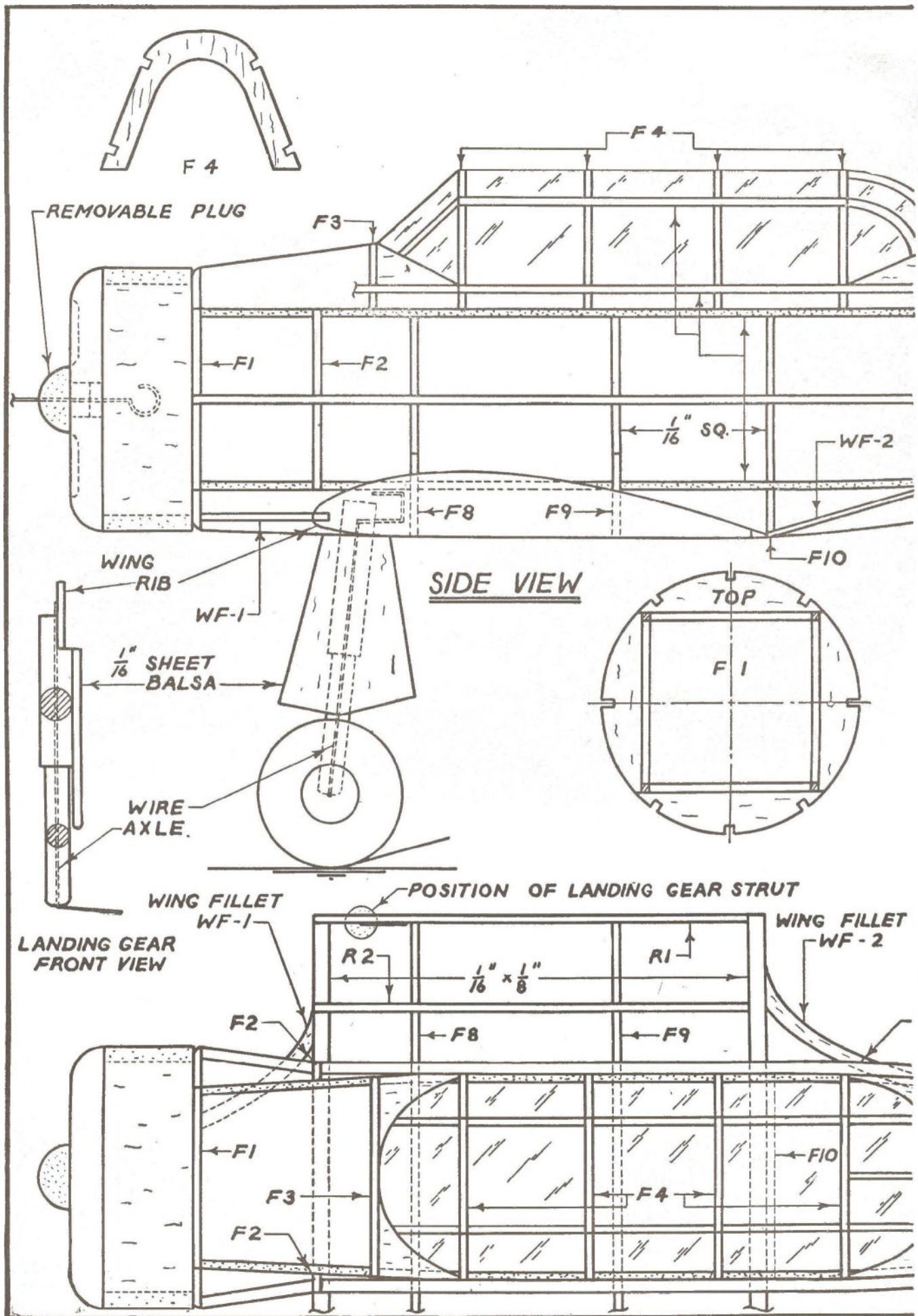

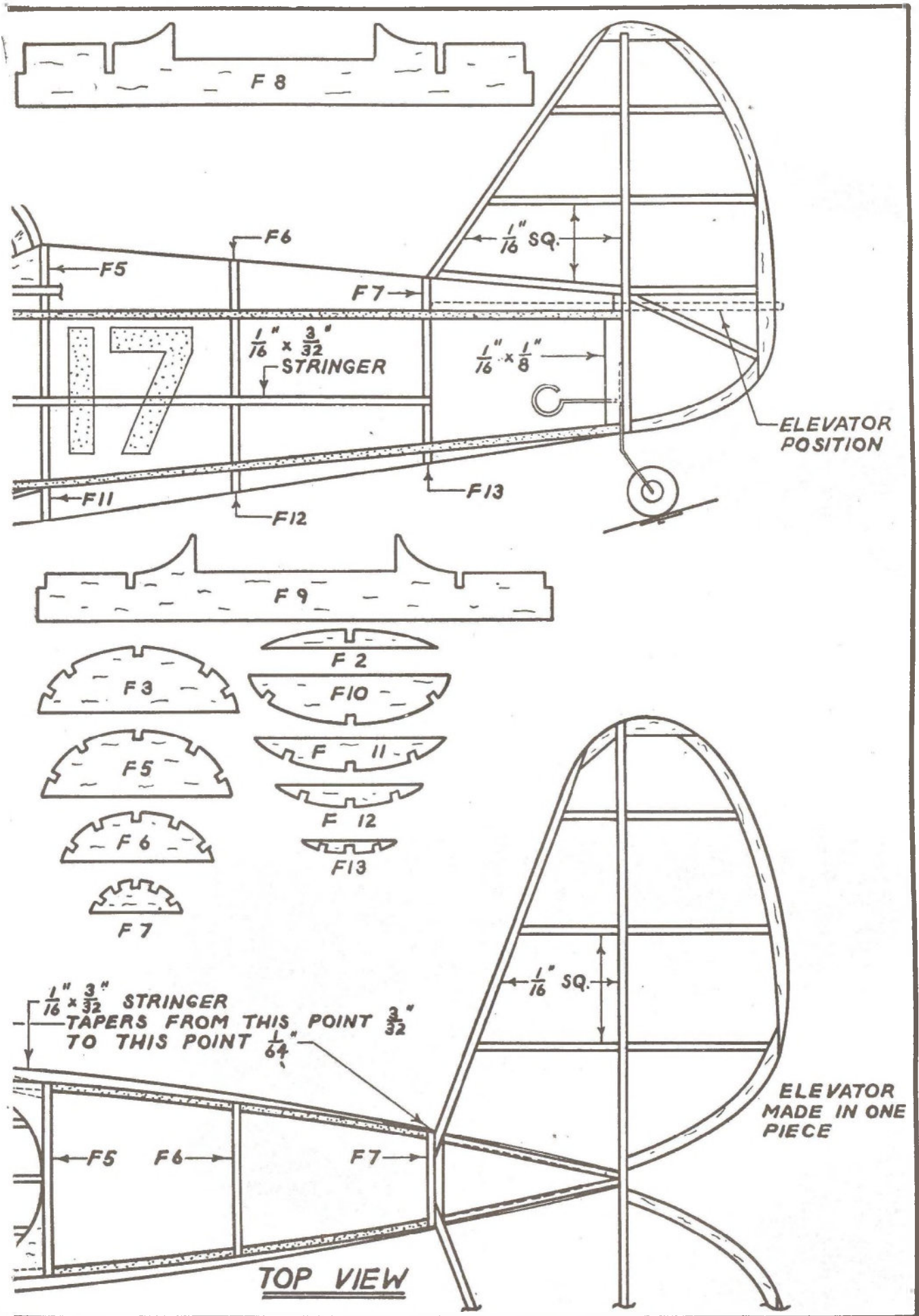

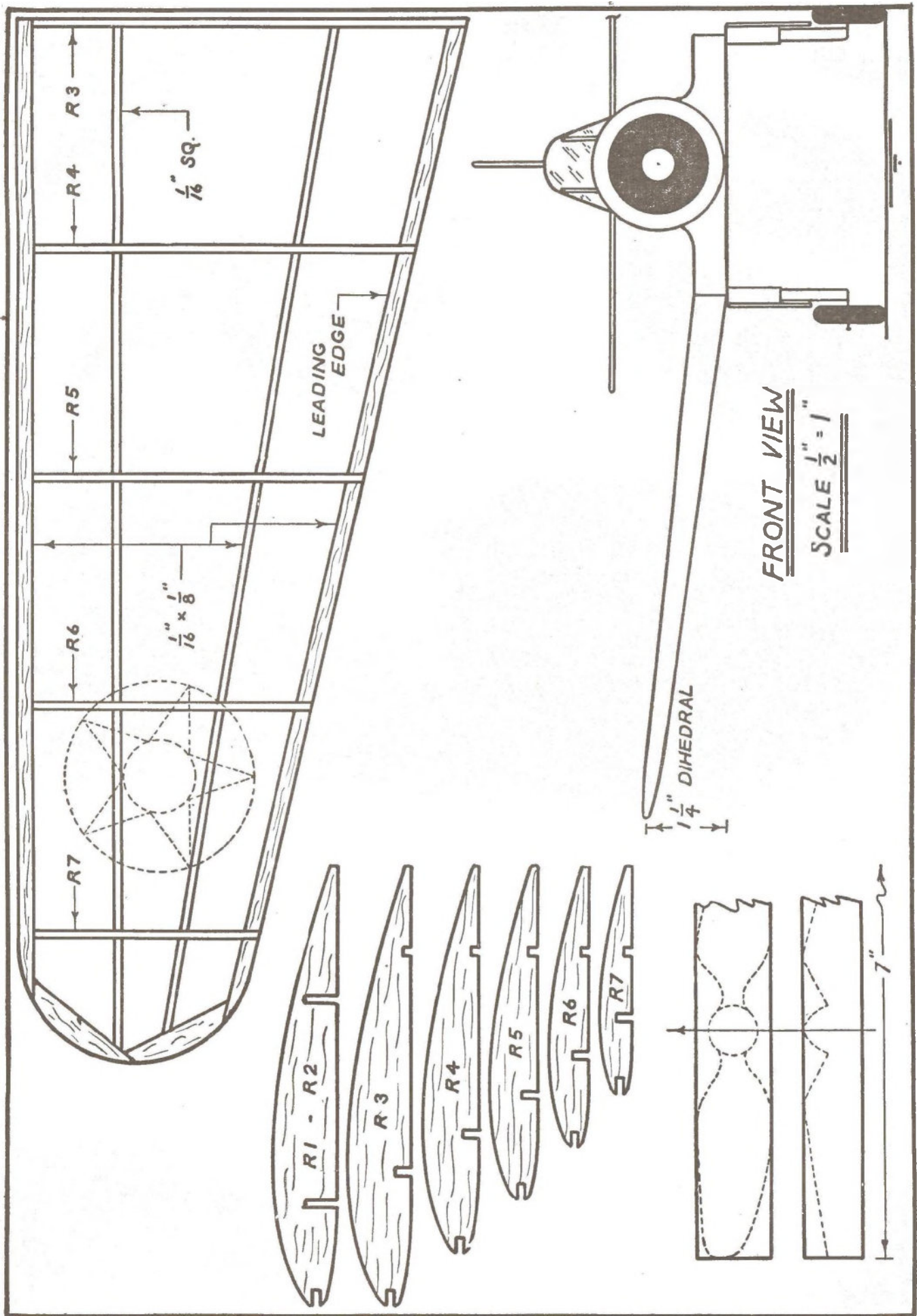



Number One: Dope along the upper main spar to fill the silk so that the tightening coat will not stick the silk covering to the spar.



Number Two: Hold the material tightly at the center section as shown. Pull the silk outward to the extreme tip, "tacking" it as you go along.

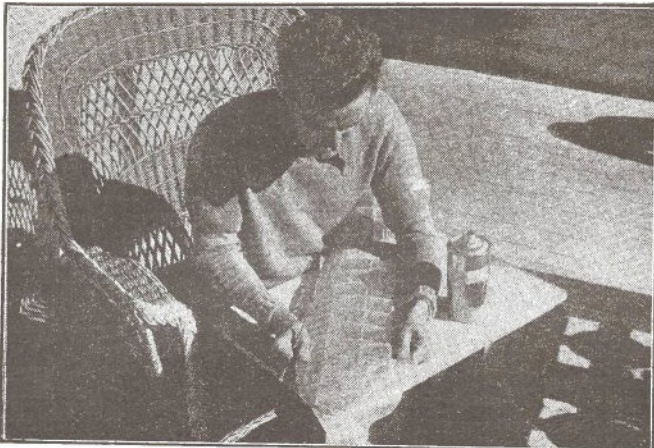

Number Three: Remove the wrinkles from the silk by pulling across the chord, at the same time working outward from the center section to tip.

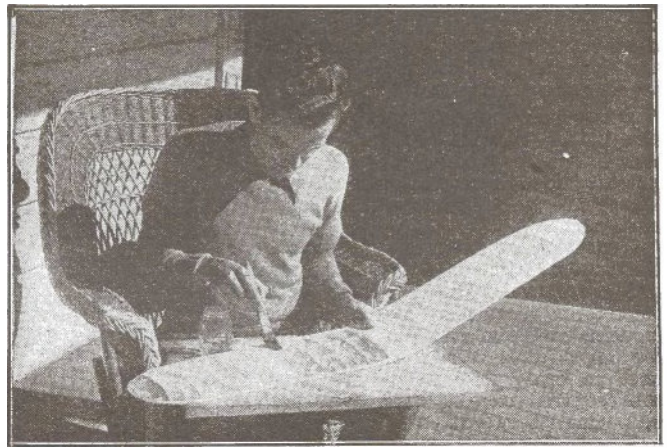

Number Four: The completely covered wing is doped chordwise. Clear dope is applied with an inch-wide brush from center section outward.

Covering Up

A poor covering job on a model plane is as unnecessary as giving a permanent hair wave to a poodle dog. Here, an expert gives you the dope on best ways and means with which to smooth out and even end that troublesome model finishing problem.

by Peter Bowers

HOW MANY times have you modelers built a beautiful ship only to ruin it by putting on a messy covering job? No doubt, this has happened to most of you at onetime or another during your model building career. The purpose of this article, therefore, is to pass on helpful suggestions and best method of covering your model planes so that in the future your efforts will attain a higher standard of workmanship. After all, many things in life are *still* judged by their surface. So let's get right down to the bottom of this important phase of aeromodeling and cover this subject thoroughly.

Gas jobs are usually faced with one of two materials—silk or bamboo paper. Small rubber powered models,

and more recently class "A" gassies, are covered with tissue paper. The method of application in each case, however, is the same. The covering is held to the framework of the craft with dope as an adhesive.

APPLYING MATERIAL

LET'S ASSUME that the first ship we are to cover is a small gas job using paper. We will start with the wing, as it is the easiest part of the model with which to begin.

First, lay a sheet of paper, larger than a single wing section, on the workbench, and then the wing panel is placed on top of it. Then trim around the paper with a pair of scissors or a razor blade, leaving a margin about half an inch wide all around the panel. Next, apply a thick coat of dope to the leading edge of the panel with a brush, and then lay the lead-

ing edge along one edge of the paper pattern. Pick up the wing and smooth the paper along the leading edge with your fingers. When the dope has set enough so that the paper can hang without pulling loose, dope each rib about one half the chord of the wing back from the leading edge. The paper is then rolled back over the ribs, smoothing it again. When the paper adheres sufficiently, repeat the process for the rear half of the wing. Work out all the wrinkles while the dope is still wet. After the dope has dried thoroughly, the whole wing should be sprayed lightly with water which will shrink the paper and remove small wrinkles.

While the water is drying, proceed with the fuselage and tail of the ship. The tail surfaces are covered in the same manner as the wing. On a flat-

(Continued on page 79)

News of the Modelers

Here are the complete, official Model Aircraft Regulations for 1941 governing sporting model aviation in America as released by the Contest Board of the AMA.

Definitions

MODEL AIRCRAFT. All aircraft of reduced size which are not capable of supporting a human being. Such aircraft are classified as indoor or outdoor models. No restrictions are placed on design of the models except that they shall meet the specifications listed in these regulations. The models must be so designed, however, that they drop no parts in flight or during take-off. Projected area of the stabilizing surface(s) in excess of 50 per cent of the projected area of the supporting surface(s) (wing area) shall be considered as supporting surface for purposes of classification and wing loading requirements.

INDOOR MODEL AIRCRAFT. A model of the indoor type is designed to fly indoors. Indoor models are classified as powered models or non-powered models. There are no weight specifications for such aircraft.

OUTDOOR MODEL AIRCRAFT. A model of the outdoor type is designed primarily to fly outdoors. Outdoor models are classified as powered models or non-powered models. There are weight specifications for all outdoor aircraft. If ballast is used to bring an outdoor model up to the required weight, such ballast shall be permanently affixed to the model.

STICK MODEL. A model of the stick type has a body composed of stick(s), tube(s), or open framework, rather than a fuselage. Models using tubes or framework to enclose the motor(s) shall have a total maximum cross-section area of the tubes or sticks not greater than $L^2/200$, where "L" equals the overall length of the model, excluding the propeller(s).

CABIN MODEL, POWERED. A powered model of the cabin type has built-up enclosed fuselage. The total maximum cross-section area of the fuselage(s) must be no less than $L^2/100$, where "L" equals the over-all length of the model, excluding the propeller(s). The fuselage(s) shall be of streamline form and have not less than 90 percent of its(their) surface area covered. Outriggers and booms may be used. When rubber is used for motive power, it shall be contained entirely within the built-up fuselage. An unfaired tubular section of a fuselage shall not be considered built-up.

CABIN MODEL, NON-POWERED. A non-powered model of the cabin type (towline glider) must have a total maximum cross-section area of the fuselage(s) of not less than $L^2/200$, where "L" equals the over-all length of the model. The fuselage shall be of streamline form and have not less than 90 percent of its surface area covered. Outriggers and booms may be used.

HAND-LAUNCHED. A model airplane is hand-launched when it is released into flight directly from the hands of the launcher. The model shall be launched from an elevation of not more than 6 feet above the ground or floor.

RISE-OFF-GROUND. A model airplane of the rise-off-ground (R.O.G.) type has a take-off gear that permits it to take off from the ground, floor, or runway, starting from a standstill under its own

power. R.O.G. models shall be held before release by pressing downward on the wing and/or fuselage lifting the hand vertically upward for release; or by holding the wing, stabilizer or rudder between the thumb and index finger and opening the fingers for release without any forward motion of the hand at any time. The take-off gear must be strong enough to support the model in a normal attitude while at rest and permit it to take off unassisted without damage, nosing over, or striking a wing tip. When one wheel is used, skids or similar devices shall be required to keep the model upright in a normal attitude and to prevent any part other than the take-off gear from touching the ground, floor or runway. Wheel(s) shall turn freely and be of such strength and size as to permit the model to taxi freely. The minimum diameter of the wheel(s) for all models powered by other than internal combustion engines(s) is as follows: one-half inch, where the projected area of the supporting surface(s) does not exceed 30 square inches; three-quarters inch, where the projected area of the supporting surface(s) exceeds 30 but is not more than 100 square inches; 1 inch, where the projected area of the supporting surface(s) exceeds 100 but is not more than 150 square inches; 1½ inches, where the projected area of the supporting surface(s) exceeds 150 but is not more than 300 square inches; and 2 inches, where the projected area of the supporting surface(s) exceeds 300 square inches.

TOWLINE-LAUNCHED. A model airplane is towline-launched when it is pulled into the air from the ground by an inextensible line. The towline shall be no longer than 100 feet and shall be released from the model by the launcher. To assist in determining the time of release, a fabric or paper streamer shall be affixed to the towline not more than 12 inches from the end which is attached to the model.

RISE-OFF-WATER. A model airplane of the rise-off-water (R.O.W.) type can take off from and alight on water and shall float unassisted. All surfaces and parts other than floats or pontoons shall be above the surface of the water. The model shall take off from the water starting from a standstill under its own power, but is not required to land on the water at the end of the flight. Indoor rise-off-water models shall demonstrate their seaworthiness by floating five seconds. Outdoor rise-off-water models shall demonstrate their seaworthiness by floating thirty seconds.

AUTOGIRO. An autogiro model is supported in flight by the action of the air on vanes which rotate freely on an approximately vertical axis, supplemented by the thrust of propeller(s) on an approximately horizontal axis. If a fixed wing is employed, the projected area of the vanes shall not be less than that of the fixed wing(s), and the sums of these projected areas shall be considered the main supporting surface(s).

ORNITHOPTER. An ornithopter model derives its lift and propulsion solely from the flapping of its wing(s). The

projected area of the wing(s) shall be taken midway between the upward and downward positions of the wing(s).

HELICOPTER. A helicopter model rises without assistance and is supported in flight solely by the life of power-driven propeller(s) and/or vane(s). The projected area of the propeller(s) and vane(s) shall be considered the supporting surface(s).

GLIDER. A glider is similar to a model airplane but differs in that it has no power plant.

Classification

MODEL AIRCRAFT POWERED BY INTERNAL COMBUSTION ENGINES(S). Models powered by internal combustion engine(s) are classified by engine(s) displacement as follows: Class A, where the displacement of the engine(s) does not exceed .20 cubic inches; Class B, where the displacement of the engine(s) exceeds .20 but is not more than .30 cubic inches; and Class C, where the displacement of the engine(s) exceeds .30 but is not more than 1.25 cubic inches. Models powered by internal combustion engine(s) shall employ a device to limit the length of the engine run.

MODEL AIRCRAFT OTHER THAN THOSE POWERED BY INTERNAL COMBUSTION ENGINE(S). All models other than those powered by internal combustion engine(s) are classified by projected area of the supporting surface(s) as follows: Class A, where the projected area of the supporting surface(s) does not exceed 30 square inches; Class B, where the projected area of the supporting surface(s) exceeds 30 but is not more than 100 square inches; Class C, where the projected area of the supporting surface(s) exceeds 100 but is not more than 150 square inches; Class D, where the projected area of the supporting surface(s) exceeds 150 but is not more than 300 square inches; and Class E, where the projected area of the supporting surface(s) exceeds 300 square inches.

Wing Loading Requirements

INDOOR. There are no wing loading (weight) requirements for indoor model aircraft.

OUTDOOR MODEL AIRCRAFT POWERED BY INTERNAL COMBUSTION ENGINE(S). All model aircraft powered by internal combustion engine(s) shall be limited to a total flying weight of not more than 7 pounds, shall weigh not less than 80 ounces for every cubic inch of engine(s) displacement, and shall weigh not less than 8 ounces for each square foot of projected supporting surface(s).

OUTDOOR MODEL AIRCRAFT POWERED BY OTHER THAN INTERNAL COMBUSTION ENGINE(S). All outdoor model aircraft powered by other than internal combustion engine(s) shall weigh, complete and ready to fly, not less than 3 ounces avoirdupois for each 100 square inches of projected supporting surface(s).

OUTDOOR MODEL AIRCRAFT, NON-POWERED. Outdoor hand-launched gliders shall weigh, complete and ready to fly, not less than 2 ounces avoirdupois for

Sponsors and trophies for the Gulf Coast Model Championships held in Mobile, Ala., December, 1940. Left to right: C. F. E. Munger, President Mobile Model Airplane Club; Jacque Hauser, Secretary-Treasurer; Don Smith, Jr., and J. R. Cooper, Vice-Presidents.



each 100 square inches of projected supporting surface(s). Outdoor towline-launched gliders shall weigh, complete and ready to fly, not less than 3 ounces avoirdupois for each 100 square inches of projected supporting surface(s).

Categories

The Academy of Model Aeronautics has established the following model aircraft categories:

● INDOOR MODEL AIRCRAFT, POWERED—Stick Models, Hand-Launched,

Class B, C, D

Stick Models, Rise-Off-Ground,

Class A, B

Stick Models, Rise-Off-Water,

Class A, B

Cabin Model, Rise-Off-Ground,

Class B, C

Cabin Model, Rise-Off-Water,

Class B, C

Autogiro, Launching Optional,

No classes for size

Ornithopter, Launching Optional,

No classes for size

Helicopter, Launching Optional,

No classes for size

● INDOOR MODEL AIRCRAFT, NON-POWERED—

Glider, Hand-Launched... Class A, B

● OUTDOOR MODEL AIRCRAFT, POWERED BY INTERNAL COMBUSTION ENGINE(S)—

Cabin Model, Rise-Off-Ground,

Class A, B, C

Cabin Model, Rise-Off-Water,

Class A, B, C

● OUTDOOR MODEL AIRCRAFT, POWERED BY OTHER THAN INTERNAL COMBUSTION ENGINE(S)—

Stick Model, Hand-Launched,

Class C, D

Stick Model, Rise-Off-Water, Class C, D

Cabin Model, Rise-Off-Ground,

Class C, D, E

Cabin Model, Rise-Off-Water, Class C, D

Autogiro, Launching Optional,

No classes for size

Ornithopter, Launching Optional,

No classes for size

Helicopter, Launching Optional,

No classes for size

● OUTDOOR MODEL AIRCRAFT, NON-POWERED—

Glider, Hand-Launched... Class B, C, D

Cabin Glider, Towline-Launched,

Class C, D, E

Official, Delayed, and Voided Delayed Flights

INDOOR MODEL AIRCRAFT, POWERED. An indoor powered model makes an official flight when it remains in the air for 60 seconds or more. An indoor powered model makes a delayed flight when it remains in the air for less than 60 seconds, hits an obstruction which prevents further flight, or hits an obstruction or another model which throws the model out of adjustment, changing its angle of flight so that it descends at an accelerated rate striking the ground or floor. Should a model hit an obstruction the timing device (stop watch) shall be permitted to run for an additional 10 seconds and if the model falls free independently and resumes flight within those 10 seconds, the timing shall continue uninterrupted and the entire performance recorded as an official flight.

If the model fails to fall free independently within the 10-second period, the timing device shall be stopped, the 10 seconds deducted from the total flight time and the entire performance recorded as a delayed flight. Three successive delayed flights displace one official flight; the duration of all delayed flights shall be recorded. If there is no official flight which surpasses the duration of a delayed flight, the contestant shall be entitled to a reinstatement of the delayed flight as his best official flight. An indoor model makes a voided delayed flight and is not credited with any duration time when it drops any part in flight or during take-off. Flights which are aided in any way, including the artificial upward displacement of air, shall be declared voided delayed flights. Pushing or touching a model during the take-off or flight constitutes a voided delayed flight.

INDOOR MODEL AIRCRAFT, NON-POWERED. All flights made by indoor gliders are official flights, regardless of duration. Delayed flights for indoor gliders are not recognized.

OUTDOOR MODEL AIRCRAFT, POWERED BY INTERNAL COMBUSTION ENGINES. An outdoor model powered by internal combustion engine(s) makes an official flight when it remains in the air for 40 seconds or more, providing that the engine run does not exceed 20 seconds. An outdoor model powered by internal combustion engine(s) makes a delayed flight when it remains in the air for less than 40 seconds, providing that the engine run does not exceed 20 seconds. Three successive delayed flights displace one official flight; the duration of all delayed flights shall be recorded. Should an outdoor model powered with an internal combustion engine collide in the air with another model, the contestant may declare the flight a delayed or official flight. If three successive flights are recorded as delayed flights, the contestant shall be entitled to the reinstatement of the longest of these three successive delayed flights as an official flight. If one or more delayed flights is(are) followed by an official flight, the contestant shall not be entitled to reinstatement of the delayed flight(s) in place of the official flight. An outdoor model powered by internal combustion engine(s) makes a voided delayed flight, and is not credited with any duration time when it drops any part in flight or during take-off. Flights which are aided in any way, including the artificial upward displacement of air, shall be declared voided delayed flights. Pushing or touching a model during take-offs or flights constitute a voided delayed flight.

Pushing or touching model during the take-off or flight constitutes a voided delayed flight. An outdoor internal combustion engine powered model makes a voided delayed flight when its engine run exceeds 20 seconds starting from the time the model is released for unassisted take-off by the contestant.

OUTDOOR MODEL AIRCRAFT, POWERED BY OTHER THAN INTERNAL COMBUSTION ENGINE(S). An outdoor model powered by other than internal combustion engine(s) makes an official flight when it remains in the air for 20 seconds or more. An outdoor model powered by other than internal combustion engine(s) makes a delayed flight when it remains in the air for less than 20 seconds. Three successive delayed flights displace one official flight; the duration of all delayed flights shall be recorded. Should an outdoor model powered by other than internal combustion engine(s) collide in the air with another model, the contestant may declare the flight a delayed or official flight. If three successive flights are recorded as delayed flights, the contestant shall be entitled to the reinstatement of the longest of these three successive delayed flights as an official flight. If one or more delayed flights is(are) followed by an official flight, the contestant shall not be entitled to reinstatement of the delayed flight(s) in place of the official flight. An outdoor model powered by other than internal combustion engine(s) makes a voided delayed flight, and is not credited with any duration time when it drops any part in flight or during take-off. Flights which are aided in any way, including the artificial upward displacement of air, shall be declared voided delayed flights. Pushing or touching a model during take-offs or flights constitute a voided delayed flight.

OUTDOOR MODEL AIRCRAFT, NON-POWERED, HAND-LAUNCHED. All flights made by outdoor hand-launched gliders are official flights, regardless of duration. Delayed flights for outdoor hand-launched gliders are not recognized.

OUTDOOR MODEL AIRCRAFT, NON-POWERED, TOWLINE-LAUNCHED. An outdoor towline-launched glider makes an official flight when it remains in the air for 20 seconds or more after the towline is released from the model. An outdoor towline-launched glider makes a delayed flight when it remains in the air for less than 20 seconds after the towline is released from the model. Three successive delayed flights displace one official flight; the duration of all delayed

(Continued on page 56)

Whittle Out a "WINDJAMMER"

This splendid little glider is just right for beginners who want to learn the fundamentals of flight.

by Hank Brody

Photos by Charles Yerlow

HERE'S a glider biplane of novel design which has been appropriately dubbed the "Windjammer" because of its ability to buck strong headwinds and mount them at an astonishing rate of climb. Simple construction makes it possible to both build and fly the little creature in one day. The use of the catapult device is optional. Since it requires driving the launching stake into the ground or having another person hold it while the launching strand is stretched, some modelers prefer to stick with the old heave method. The writer, however, suggests that sticking with the "stick" makes for flights that'll stick in your mind!

WING AND TAIL

FULL scale plans allow the wing panel and other parts to be traced directly from the opposite page without having to remove it from the magazine. Simply place a regular sheet of typewriter carbon beneath the opposite plate and under that a page size piece of stiff paper—Manila, if handy.

Make one distinct impression of the wing outline. While you're at it, draw the outlines for the stabilizer, rudder and wing struts. Use a pair of scissors to cut out the patterns and proceed to trace them onto the required wood as noted on the plan.

Trace the wing template onto sheets of medium balsa each one measuring $\frac{3}{8}$ " by $2\frac{1}{2}$ " by 7". Use a keen-edged razor to trim the outlines right down to the pencil lines. When all four panels are identical, sand the edges smooth.

The wing cross section shown on the plan is especially suited for this type of glider as it offers the least amount of drag and the greatest amount of lift. To obtain a perfect profile section which may be transferred to your wing, it is best to make a stiff paper template first. Use a razor to cut its outlines. Then, measuring half an inch all around the airfoil, draw a margin outline and trim to size. This makes a handy template and can be used only at that part of the wing which is widest. From that point on, the airfoil section tapers both in plan and in thickness. Use medium and smooth sandpaper in turn to shape the required lift section. All four panels should be identical. The secret of lasting flights lies in a perpetual smooth flow over the lifting surfaces. Both the rudder and stabilizer are made of $\frac{1}{8}$ " sheet medium balsa. One half of the elevator outline is shown. The center line indicates the necessity of making just half a template. This is traced onto the wood, turned over and its outlines continued for a full stabilizer layout.

The rudder outline is complete. Both parts should be streamlined as shown by the side view of the stabilizer's position at the extreme end of the body. The wing strut templates are traced onto $\frac{1}{8}$ " medium balsa sheet and trimmed to shape with a razor. Two struts are required for "B" and a single one for "A." Use smooth sandpaper to obtain the streamline shape that is indicated by the cross sectional view on the plan.

FUSELAGE STICK
THE FUSELAGE outlines are traced onto a piece of stiff paper to make a continuous length. It may be necessary to glue two parts of the paper together in order to get

Sleek looking? She's even better when viewed under actual flight.

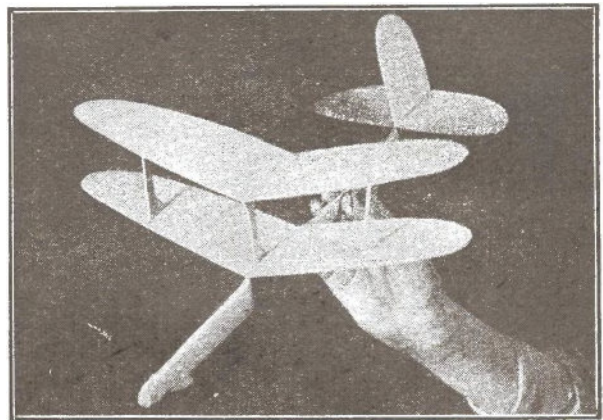

Rigid construction enables this glider biplane to withstand rugged outdoor usage. Twin dihedral wings give it great stability.

a single length. Trace the template outlines onto a selected piece of hard balsa measuring $\frac{1}{4}$ " by 1" by 15".

Using the same system required to make a wing section template, "slip on" templates for the body stations may be made so that the cross section of the body is consistent with the plans. It won't be necessary to resort to the knife to carve the fuselage if rough sandpaper is skillfully used. When the shape of the body takes place, try slipping on the cross section templates. In this manner you will be able to determine just how far down you may keep sanding to the finish line.

After the body has been sanded to perfection, fold the edge of your sandpaper and sand the "V" shaped dihedral notch in the part of the body that accommodates the wings. The notch should be made to the exact depth indicated on the plan. The tail end top of the stick should be flat for the stabilizer rest.

The catapult device is traced onto a piece of $1/16$ " sheet hard balsa. Note the direction of the grain in the wood. Cement the device as shown. When dry, bend a piece of piano wire to adhere to the outlines of the device. Insert the prongs into the body and apply a thick film of cement over the entire area.

All wood parts should be given three coats of thick dope. After each coat has thoroughly dried, sand lightly to remove the resultant coarseness. If the builder wishes, he may apply additional coats of dope.

ASSEMBLY AND FLYING

AT TACH the stabilizer in position first. Be sure it lies perfectly flat while drying. The rudder is cemented next. When the tail is set, cement lower wing panels into notch. Insert small model masking pins to maintain the dihedral angle until the

(Continued on page 75)

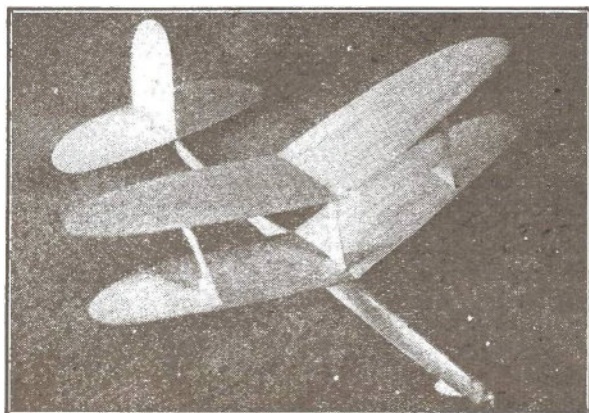

FULL-SCALE PLAN FOR THE "WINDJAMMER"

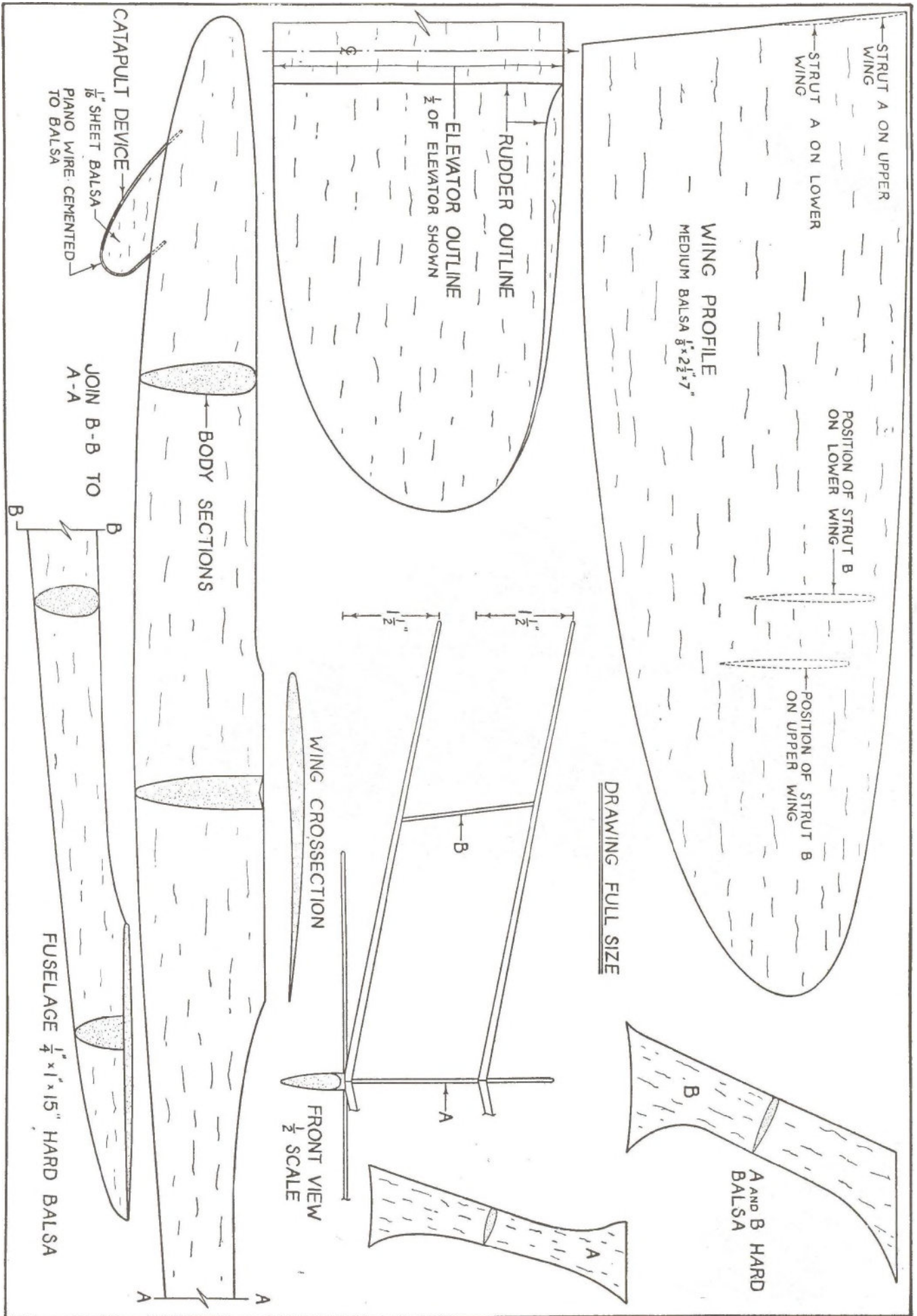

F.A. MODEL SCOOP—HOWARD DGA TRAINER

GENERAL

ENGINE - 125 H.P. RADIAL WARNER SCARAB-SERIES 50
 (STRESSED FOR 165 H.P.)
 PROPELLER - WOOD
 IGNITION - DUAL
 WINGS - PLYWOOD COVERED
 STABILIZER - FIXED
 ELEVATOR - TRIM TAB
 WING TIPS - REPLACEABLE
 SHOCK ABSORBERS - SPRING DRAULIC

LANDING GEAR - FIXED
 BRAKES - HYDRAULIC
 TIRES - 8.00x5
 TAIL WHEEL - STEERABLE

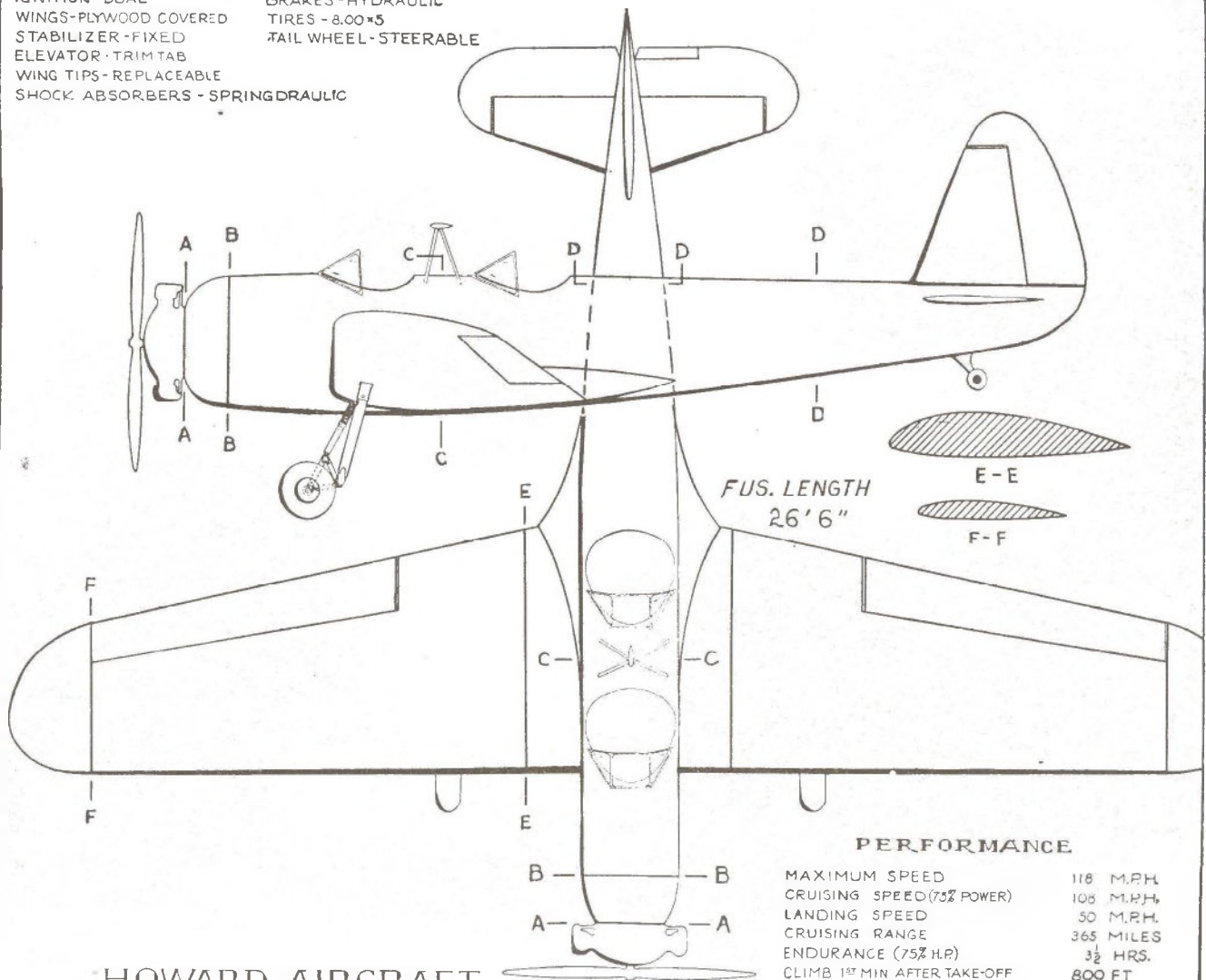

HOWARD AIRCRAFT

PERFORMANCE

MAXIMUM SPEED	118 M.P.H.
CRUISING SPEED (75% POWER)	108 M.P.H.
LANDING SPEED	50 M.P.H.
CRUISING RANGE	365 MILES
ENDURANCE (75% H.P.)	3½ HRS.
CLIMB 1st MIN AFTER TAKE-OFF	800 FT.
CLIMB TO 3,000 FEET	9½ MIN.
TAKE OFF RUN	650 FT.
SERVICE CEILING	13,500 FT.

DGA-125 TRAINER ————— 340 —————

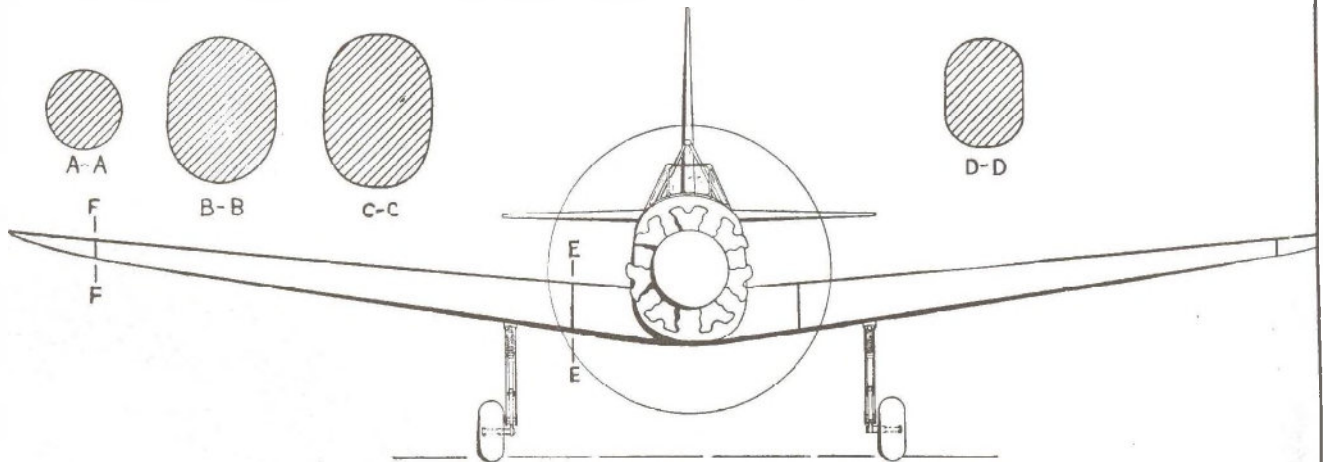

DESIGNED ESPECIALLY FOR

SECONDARY (ADVANCED) AND INSTRUCTOR COURSES
 OF THE CIVILIAN PILOT TRAINING PROGRAM

MILT KAHN

THE FACT that you are reading this article proves that you are interested in aviation. Are you interested enough to spend a little time to remodel your name into the shape of an airplane? If you are, here's how.

Designing your name into the shape of an airplane isn't difficult if you go about it systematically. Some names will fit several types of planes while others seem to fit one particular type. Therefore, the best thing to do is to look over the drawing below and see what has been done with names similar to your own. Possibly your name is among them. If it is, so much the better. The work is all done for you. But that doesn't mean that you can't write up your name in some other way or that you can't add your own ideas for improvement. The illustrations are just a few samples covering as wide a range as possible so as to give you a fairly good start to make that "name" for yourself.

There are quite a few complete names worked out and also a large number of combinations of a few letters each which can be worked in at different places. These examples show how different letters of the alphabet can be formed into different parts of a plane.

If your name is quite long you'll probably have to crowd the letters. If it's short you will have to stretch them all out. If you haven't found a good lead in the examples start with any type.

Sketch the outline of the airplane lightly on a piece of paper. Don't make it too small at the start, as it will be too hard to work with. Begin as if you were going to print your name out from left to right, taking the first letter and sketching it in the first part of the plane so that it fills the outline. Sketch in the second letter and so on.

If you fill up the entire space before you have finished with your name just go back over it and "squeeze" the letters a little closer together. On the other hand, if you run out of letters you will have to spread them out a little more in order to fill up the entire outline. Try your first and last name together, then your initials and last name, your initials alone, or first name alone.

Experiment with the letters if they don't seem to fill up the space and try to arrange them so they will. If the letters just won't come in the right places for the style of plane you started with, try some other style.

There are four different top views of a plane illustrated in the corners of the page. Try out all of them. If they don't seem to be satisfactory try the different side views shown. Perhaps you can use a landing gear to good advantage and then again your name may fit in nicely without a landing gear. Each type has its advantages. Decide whether the first letter of your name would make a good cowling or nose, or whether it would be better as a rudder or ele-

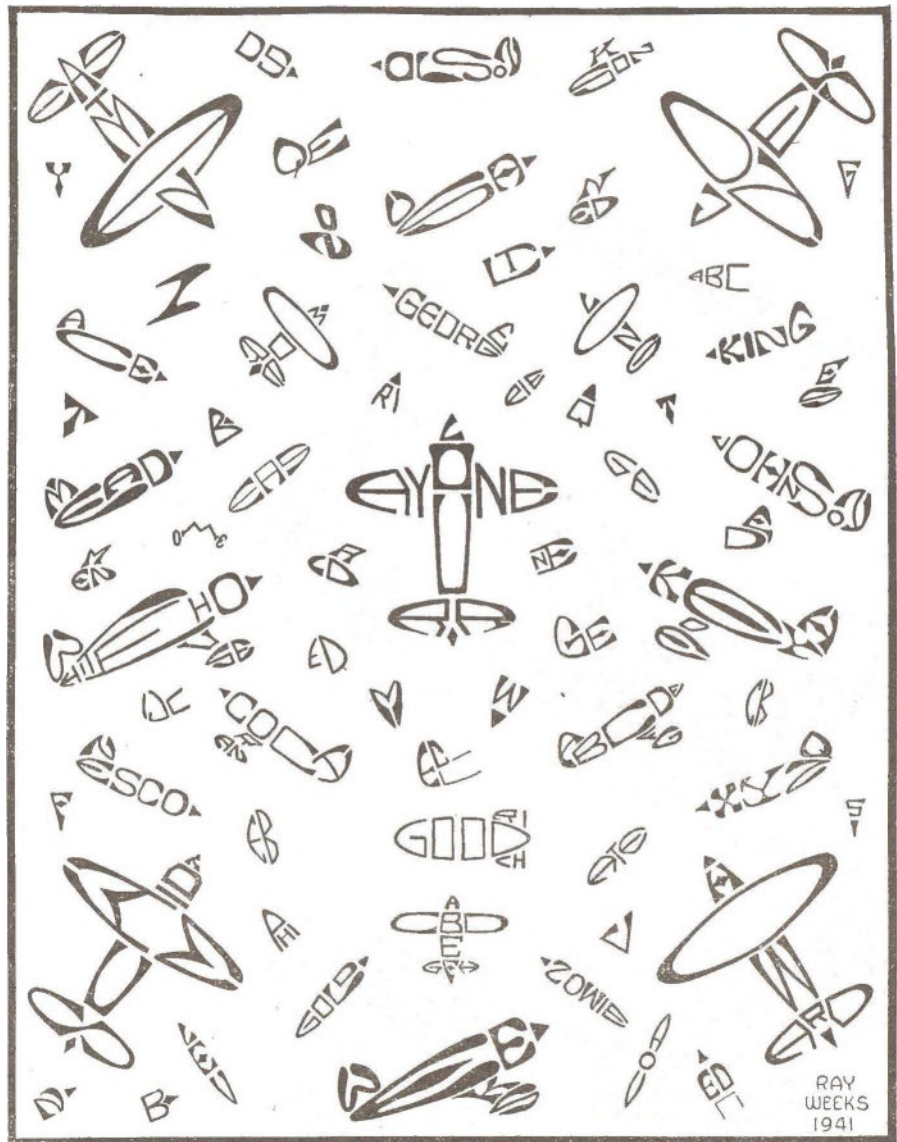

STREAMLINE YOUR NAME

If you ever hope to make a "name" for yourself in aviation, this is the time to start!

by Ray Weeks

vator. Then pick the style of plane accordingly.

Once you have found the type best suited to your needs and which allows your name to be easily read you can start trimming it up. Study the chart and observe how some parts of the letters are thin and other parts thick. How some are extended and others are condensed in order to balance the plane so it doesn't seem lopsided in any way. Study the examples shown and use them as a guide in completing your name. Try having the letters close enough together so that the plane doesn't seem disjointed, but still not so close that the individual letters are hard to make out. Add lines to indicate speed however

you like. Don't use too many. Lines were not used in this illustration in order to avoid confusion.

Once you've mastered the technique you'll probably want to flash your name on the fuselage of your ship or school notebook. For that purpose, use either a good grade of paper that won't buckle under inking or regular tracing linen.

For your general information the following are names used in the illustrations. Left to right and top to bottom: Eastman, Olson, Jones, U.S.A., Ace, Moore, George, Long, King, Mead, Lourrayne, Johnson, Whitehouse, Keyhoe, Cochran, Nesco, Goodrich, Schmidt, Weeks and Howard.

THE END

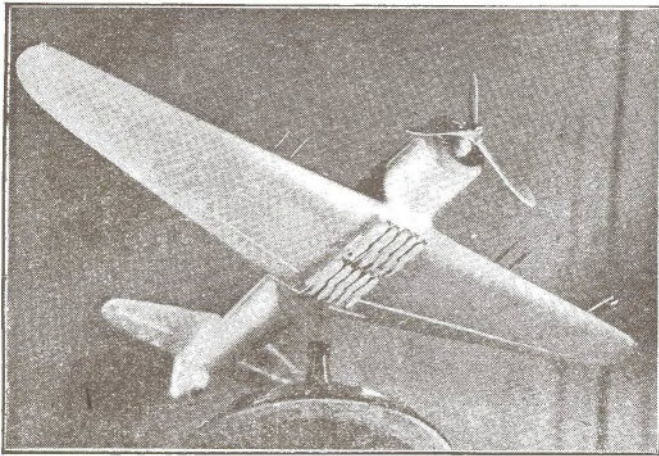

Bombs and machine guns give the model a realistic appearance.

BY JACK KOLTON

HERE'S a clean-lined job that adapts itself easily for solid scale modeling purposes. The ship shown in the photos has been mounted on a permanent pedestal base and no landing gear has been attached. The choice of making a landing gear or the mount as shown is optional.

Knowing something about the airplane you're duplicating is always interesting. This particular design first saw daylight about four years ago. It was built expressly for export service and more than a hundred now are used by the airforce of Turkey (insignia shown on plans) China, and Russia. The VII-GB carries a crew of three; pilot, gunner, and bombardier. It is powered with a Wright Cyclone of 850 h.p., carries twenty 30-pound bombs, 2,400 rounds of ammunition for the four forward guns, and has a top speed at sea level of 236 m.p.h. The cruising range is 2,770 miles.

The all-metal fuselage is built in three sections, each of which may be unbolted and replaced with another one if serious damage occurs. The leading edge and wing tips are removable so that ground crew men can make any adjustments in the interior of the panel itself. The landing gear retracts into the center section forward of the front spar. Two tanks are in the body and four in the wings.

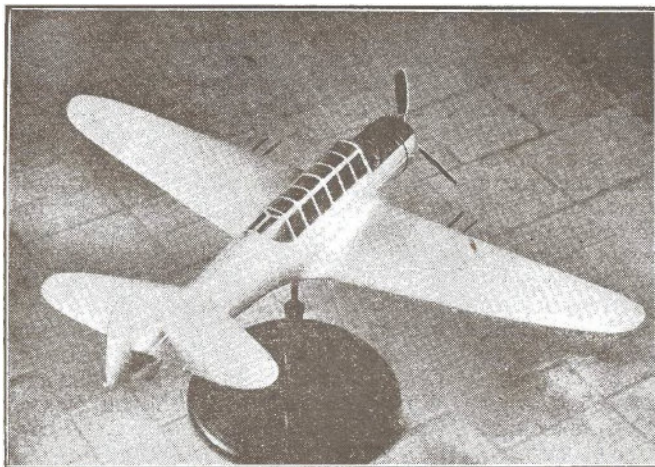

Carve a Solid Scale

Vultee V-11GB

Three-view drawings on the opposite page provide accurate details for building a fine replica job.

CARVING THE FUSELAGE

IF YOU wish to build this craft any size other than that shown on the opposite plan; it will then be best to have it photostated to the de-

sired size. The use of a scale rule and a pair of dividers can come to the aid of those who haven't the convenience of a photo-copier.

The entire ship is made of medium strength balsa. Having cut out stiff paper patterns, take the top view template and trace it onto the block. Use a sharp knife or a jig saw to trim down to the lines. Next, trace out the side view. The "glass house" enclosure may be left an integral part of the body or cut away. If left, then the windows and frames must be painted in.

The exposed portions of the body such as the exhaust stack, air intake, radio shield, and tail wheel housing are added on later. Use coarse and smooth sandpaper successively until a fine finish is obtained. Check with the cross sections of the body for accuracy. The cockpit housing is built up by half curved wire frames whose prongs are imbedded into the body sides. Sections of thin sheet celluloid are attached with cement. The wire frames may be painted black before the celluloid is applied.

Depending on the size of the model, a miniature Cyclone engine may be built

inside the cowling. If the model is made direct from the plans, simply make a slight indentation in the cowling, clean it out with sandpaper and paint black.

By checking against the front view on the plan you will be able to measure exactly how much wood should be cut from the belly in order to

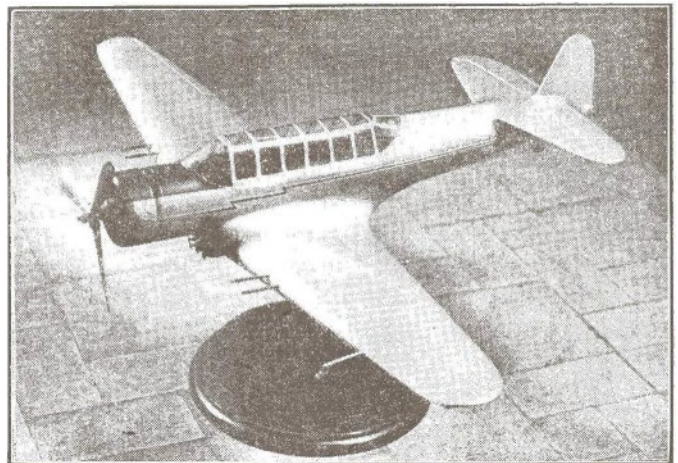

Mounted on a pedestal, it makes an attractive display job.

mount the wing. Trace the outline of the airfoil at its thickest point, and cut away the unnecessary surface with a coping saw. Add the exposed parts to the engine cowl and carve a separate piece for the tail wheel housing. This part should fillet into the body as if it were an integral part.

WINGS, TAIL, AND LANDING GEAR

THE CENTER section and wing panels, for the sake of avoiding unnecessary work, may be made in one piece. Make a full layout pattern and trace it onto the wood. Use a jig saw to cut out the entire plan view. Then with a small block plane, shave the wing into an approximate airfoil section. Use sandpaper to do the rest of the job. The finish should be perfectly smooth.

Tail parts should be cut to shape from medium strength sheet and streamlined to plan views. Pencil lines drawn on the rudder and stabilizer give the hinged surfaces a realistic effect.

The landing gear leg is trimmed to shape from a single piece of extra hard sheet balsa. Note, as shown in the front view, how the leg tapers at the bottom. The outside folding flaps

(Continued on page 66)

Smoothly filleted surfaces add to the craftsman-like finish.

CARVE A SOLID VULTEE ATTACK-BOMBER

VULTEE V-II GB
ATTACK-BOMBER

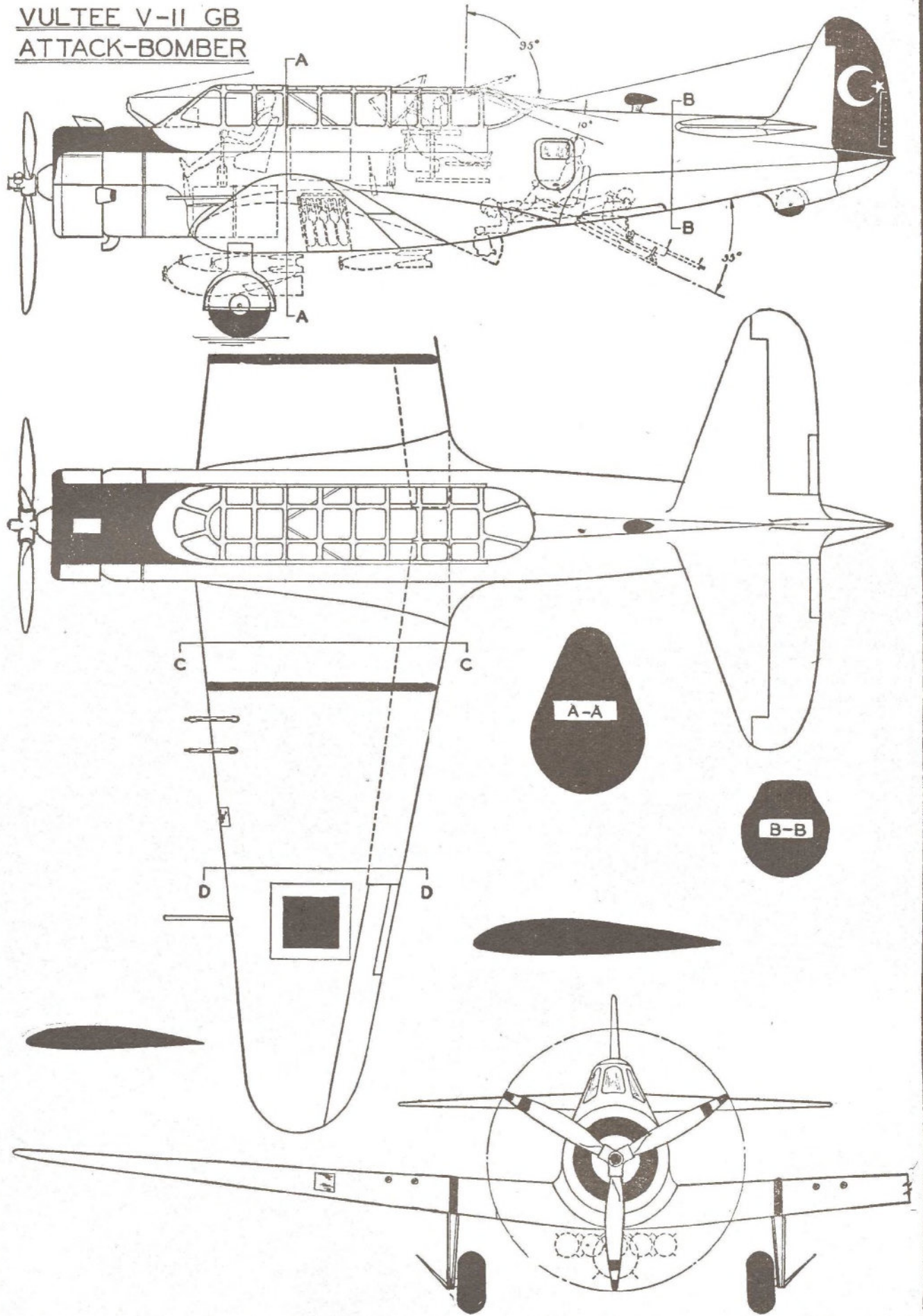

MODEL NEWS

(Continued from page 49)

flights shall be recorded. Should an outdoor towline glider collide in the air with another model, the contestant may declare the flight a delayed or official flight. If three successive flights are recorded as delayed flights, the contestant shall be entitled to the reinstatement of the longest of these three successive delayed flights as an official flight. If one or more delayed flights is followed by an official flight the contestant shall not be entitled to reinstatement of the delayed flight(s) in place of the official flight. An outdoor towline glider makes a voided delayed flight, and is not credited with any duration time when it drops any part in flight or during take-off. Flights which are aided in any way, including the artificial upward displacement of air, shall be declared voided delayed flights.

Number of Flights

INDOOR MODEL AIRCRAFT, POWERED. Each contestant shall be allowed a total

of 3 official flights, with 3 successive delayed flights displacing one official flight.

INDOOR MODEL AIRCRAFT, NON-POWERED. Each contestant shall be allowed a total of 9 official flights.

OUTDOOR MODEL AIRCRAFT, POWERED. Each contestant shall be allowed a total of 3 official flights in all outdoor powered model events, with 3 successive delayed flights displacing one official flight.

OUTDOOR MODEL AIRCRAFT, NON-POWERED, HAND-LAUNCHED. Each contestant shall be allowed a total of 9 flights.

OUTDOOR MODEL AIRCRAFT, NON-POWERED, TOWLINE-LAUNCHED. Each contestant shall be allowed a total of 3 official flights in outdoor towline-launched glider events, with 3 successive delayed flights displacing one official flight.

RECORD TRIALS. Unlimited number of flights are permitted in record trials provided sufficient timing equipment is available; the scoring of such flights, however, shall be according to the standard established for sanctioned competition.

Timing of Flights

INDOOR. Time of flight starts the instant a model is launched by hand or re-

leased for take-off and ends when the model touches the ground or floor after being launched, or meets an obstruction that prevents further flight.

OUTDOOR. Time of flight starts the instant a model is launched by hand or released for take-off and ends when the model touches the terrain after being launched, or meets an obstruction that prevents further flight. Time also ends when a model passes from the sight of the timer; should a model pass from sight of the timer behind a cloud or obstruction, the timing device (stop watch) shall be permitted to run for an additional 10 seconds and if the model reappears within those 10 seconds, the timing shall continue uninterrupted. If the model fails to reappear within those 10 seconds, the timing device shall be stopped and the 10 seconds deducted from the total official flight time. The timer shall make every effort to keep a model in sight until it lands. Timers at an outdoor contest shall remain on the field within a prescribed circle not to exceed 200 feet in radius, and timers shall keep models in sight only by use of normal vision.

(Continued on page 66)

Logging the Motor Market

The Elf Single

THIS CLASS "A" motor, the manufacturers claim, is best suited for model planes having a three foot span or less. Designed with this object in view, the modeler can cowl the engine neatly since the spark plug is mounted in the rear of the cylinder. The carburetor, timer, choke, and gas tank are easily accessible through a small door on the top of the cowling.

The weight of all the moving parts of the engine is less than one ounce. The rest of the two ounce weight is made up by a heavy cast frame. The cylinder and crankcase are made of sand cast aluminum. An aluminum forged piston is machined to close tolerances. No piston rings are used. The connecting rod is machined from solid dural and tool steel is used to make the wrist pin. The timer is enclosed and adjustable.

The engine may be inverted simply by turning the carburetor around in its hole. The timer is inverted by turning it 180 degrees and removing

a wire cam and replacing it in the opposite hole in the crankshaft. The carburetor is equipped with a filter. Lubrication for the Single requires one part of No. 40 oil to three parts of white gas.

Specifications: Bare weight, 3 ounces; flying weight, including batteries, 6.24 ounces; displacement, .097 cubic inches; bore, 15/32"; stroke, 9/16"; cycle, 2; ports, 4; rated h.p., 1/14; r.p.m., up to 7,500; propeller diameter, 8"; pitch, 5 1/2".

Minimum weight of plane using this engine allowed under AMA contest rules is 7.76 ounces. The engine is block tested and guaranteed.

Barker Model "B"

EXCLUSIVE features built in the 1/4 h.p. Barker Model "B" Class "C" engine were designed to provide long wear and uninterrupted operation, according to the manufacturers.

The cylinder head is cast aluminum, machined to an airflow design for maximum cooling. Copper gaskets are used to prevent compression leakage. The cylinder is machined from a single piece of chrome nickel iron and fastened to the crankcase by four bolts.

The piston is ground and lapped from gray iron. A one piece drop-forged steel crankshaft is hardened, ground, fully counter-balanced, and drilled for oiling. Tubular steel is used for the wrist pin which is also hardened, and ground.

The connecting rod is machined

from Phosphor bronze. Bearings are burnished to size. A hot-spot exhaust manifold pre-heats the incoming gas, assuring a perfect mixture. A nozzle type needle valve is used to permit easy starting. The special timer mounting is self-contained and is held by constant spring tension in line with the cam against a machined surface.

The gas tank is machined Duralmetal, streamlined, and equipped with a snap filler cap. Piston rings are heat shaped of cast iron. Both spark coil and condenser are made by Smith.

Specifications: Flying weight, including batteries, 16 ounces; bore, 15/15"; stroke, 1"; cycle, 2; ports, 3; minimum r.p.m., 1,000; maximum r.p.m., 7,000; fuel ratio, 3 parts white gas, 1 part 70 oil; propeller diameter, 15"; pitch, 10".

Minimum weight of plane using this engine allowed under AMA contest rules is 55.2 ounces. This engine is block tested and guaranteed.

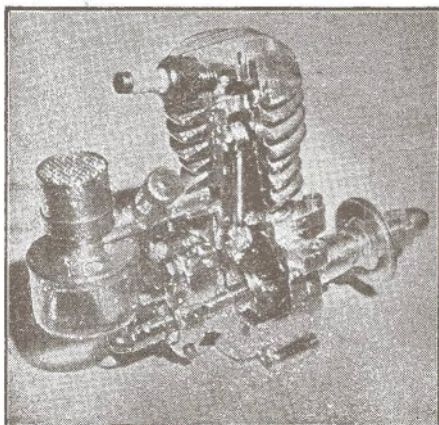

Left: The Class "A" Elf Single.
Right: Barker Model "B."

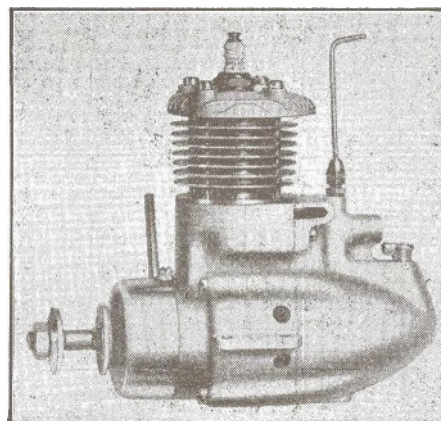

You Said it!

Here's your corner, buzzards, and it's open to all readers who have a model argument they want to get off their respective chests. Make your comments short and snappy, and we'll try to squeeze 'em in.

"Hurricane"—Contest Copper

Model Editor, FLYING ACES:

The Bridgeport Aeronauts recently decided to hold a low-wing contest, so I dug into my F.A. files and brought up plans of "Hurricane" (July, 1940, F.A.) and built it. It took first place in that contest and I received a nifty cash award.

Being a success another low-wing contest was held in January and the "Hurricane" again took first place. Hat's off to Stahl models!

CHICK GARNETT,
Stratford, Conn.

"Hi-Climber" Rates High

Model Editor, FLYING ACES:

I have read your magazine for some time now and I think the model section is swell—but not large enough. Being the only modeler around town, I look to your section for the "dream plane" and some day I hope to find it.

The people in this neighborhood think model building is child's play and a waste of time. But when I flew your "Hi-Climber" they soon changed their minds.

CHARLES DERRY,
Lanham, Md.

Model Editor, FLYING ACES:

The "You Said It!" corner gives me a laugh. Someone is always complaining about something or other but I'm an easy guy to satisfy. For instance, I built the "Hi-Climber" and the first one copped a contest

hands down. I built three others and they performed above par.

Now why should anyone complain about your model section? Here's to more ships like the contest copping "Hi-Climber." I also agree with Joe Lefsky that there's no future in testing spark plugs through your hand. Ouch!

BILL HOPKINS,
Bronx, N. Y.

"Cabinaire" Popular

Model Editor, FLYING ACES:

I wish to send a vote of thanks to Bob Brown for making such a swell job of designing the "Cabinaire." The ship was completed in four days at the cost of forty cents.

No flight was under 30 seconds and I've never seen a more stable flyer. Here's to more unique ships like the cabin job and let's have more of them.

JOHN HOPKINS,
Toronto, Can.

Model Editor, FLYING ACES:

The "Cabinaire" (December, 1940, F. A.) is tops with me. It flew 51 seconds on 300 turns. I've built many of your planes and this one beats them all.

JACK HENRICKSON,
Estacada, Ore.

Solid on Three-Views

Model Editor, FLYING ACES:

I advise your mag to have more solid scale jobs and three-view drawings. I like Ray Weeks' "Notes from the Workbench" very much.

E. A. HOOD,
Brooklyn, N. Y.

Likes Theory Articles

Model Editor, FLYING ACES:

That article by Thracy Petrides, "Secrets of Endurance" (February,

1941, F. A.), was really swell! Let's have some more of these educational articles.

THANOS VAXEVANIDES,
New York City

"Thermal Chaser" Chased

Model Editor, FLYING ACES:

I've just completed the "Thermal Chaser" (October, 1940, F. A.) and, believe you me, it's the best little flyer I ever did see! It just spirals up to 300 feet, levels off, and glides flatter than a musician's error!

Before actually flying, it was set aside while the coat of dope was drying. Along came a Japanese beetle doing a 9-G, and it went through the wing like greased lightning. But don't worry, I sure fixed that beetle's wagon!

JACK HILL,
New York City

Workbench Tip

To Keep F.A.'s in Shape

Many model builders who build ships from plans published in FLYING ACES like to preserve the copies for further reference with all pages intact. This simple tip should be of great assistance.

Remove the metal fastenings that hold the magazine together and take out the double sheet that contains the model plans. After working the plans and your model is completed, place the pages back in numerical order and fasten the clips as they formerly were. In this manner, the pages are not torn and the model can be built (in some cases full scale) without the use of carbon paper, except for tracing ribs.

MAX ROSSOFF,
Brooklyn, N. Y.

WIDE OPEN AND ZOOMING

for the

Next Great FLYING ACES

FACT—You'll never fully realize how much actual labor goes into the making of an airplane until you work in an aircraft factory, but Frank Mackay paints a vivid picture and explains the task as well as possible.

And, of course, we'll have five more feature articles, along with the usual departments, in accordance with our new style.

FICTION—Swashbuckling Eric Trent and Mort Crabb in another thriller. Coffin Kirk and Tank in the Far East.

And, of course, our old pal Phineas once again.

MODEL BUILDING—Bob Hayos' unique slotted-wing gas job.

"It's the Finish That Counts" says Francis Savarese. Plus Eddie Shane's novel pusher glider.

In June FLYING ACES

On Sale April 25 (Canada One Week Later)

RAIDER WINGS IN THE PACIFIC

(Continued from page 17)

jump to make. He probably decided against a gunner to save extra weight."

"What's the position?" Weldon asked, also in a low voice.

"Approximately 120 miles southwest of Tainen Island. Do you know any reason why the fleet would be going to Tainen?"

"No. I never even heard of it until that hellish voice whispered it tonight. Where is it?"

"Over 400 miles north of here. It's one of the few that Japan didn't get when they were given a mandate over German islands seized in the World War. Sweden and the United States both claimed it, but it had no real value and nothing was ever done about it. At least, the island was deserted when I was out there."

"Come on back to the office," said Weldon. "I want to send a cable to Washington. We'll try to figure out this thing afterward."

As they started for the airline offices Hall caught up with them. "Governor, is it safe to radio San Francisco about this?" he said anxiously.

"No!" snapped Weldon. "Everything out of here will have to be censored from now on. What's the trouble?"

"We've got to have a new set of flippers, rudder horns, and tail control rods. Those two Jap ships shot up the Clipper's tail after they finished Miller's plane. Even if new parts are flown out here in the next Clipper, it'll be at least ten days before this ship can take off."

"I'll cover it in a cable. You can give me a list of what you need."

All the station lights were out when they reached the office.

"We can't keep the bulbs burning more than a minute or two, Mr. Hall," reported an airline attendant. "That crazy music's still pouring in and the lights get that funny color, like the old mercury-vapor lamps. Then they burn out."

"This is one time your trouble comes in handy, Knight," Weldon said as they went inside. "Hand me the phone, will you?"

Knight steered him to the desk, put the phone in his hand.

"Cable Station," Weldon barked into the mouthpiece. Then, after a few seconds, "This is Governor Weldon. Get me Superintendent Hindley. I want to get a code cable off to Washington immediately—what's that?"

A moment later he put down the phone. Knight saw the look on his plump face.

"Gone dead?" he queried.

"Both American cables," Weldon said in a stunned voice. "We can't get Manila or Honolulu."

"Holy mackerel!" erupted Doyle. "You mean that goofy music's put a jinx on the cables, too?"

"No. They've apparently been cut.

The westward cable, to Manila, went dead ten minutes before the lights began to act up. The one to Honolulu and San Francisco went out just a few minutes ago. They've a Wheatstone bridge device that shows the location of breaks—it measures the difference in resistance some way—and they've already spotted the points. Both cables were cut within a mile of the station."

"Then it must have been sabotage here on the island," Knight, said quickly.

"Not necessarily. The cables lead down the hill and into the water in less than that distance. It could have been done by a submarine. They'd have had to sneak into the harbor, but it's not impossible. Hindley's men are checking up, but it may be several days before service is restored. They'll have to wait for a diver to be flown in from Honolulu if the breaks are under water."

"Then we're cut off completely," said Knight. "No communications, and with that Clipper wrecked there's no way to fly word out."

"I'm going to try Navy Radio. They've a more powerful set than the airline. Maybe we can get through."

TWO MINUTES later Weldon put down the phone, shook his head. "All the receiver tubes have burned out, the same as the lights. The transmitter tubes have turned that same greenish-purple color and they're picking up that devilish music."

"Do the operators have any idea what it is or where it's coming from?" asked Knight.

"They don't know what it is, but they say it's some kind of electrical impulse that blankets radio frequencies. It registers on the direction-finder—"

"If they can spot where it's from, we can hit it!" boomed Doyle.

"It's coming on a bearing of 347 degrees," said Weldon. "Knight! Isn't that where the fleet is?"

Knight stared down at the map. "No, it's a direct bearing on Tainen Island."

"We've got to lick this!" Weldon said desperately. "Do you realize we may be at war—and Washington won't know it for days? The fleet has orders to keep their radio silent and send all communications through here by special cables. With a three- or four-day jump on us, Japan might—"

"Wait a minute," Knight said calmly. "Suppose you give us the whole set-up, then we'll try to figure a way out. How much of the fleet is out here?"

"About half of it," Weldon said thickly. "Naval Intelligence got word of a Jap scheme to strike at the Philippines and finish off our Asiatic Squadron with a surprise attack.

The Asiatic Squadron isn't strong enough to hold out more than a few hours against the Japs. They'd be in the Philippines, with Corregidor wrecked by bombers, before the fleet could get out of Pearl Harbor at Honolulu. On top of that, we had authentic reports of some new battleships they've built secretly—two super-cruisers faster than anything we've got, and at least one 45,000-ton dreadnaught.

"When the fleet was ordered out on routine maneuvers two weeks ago, it was to cover up a counter-move against the Jap plan. Seven dreadnaughts and ten cruisers steamed to a point sixty miles south of here and we worked up a communications plan, with courier-pilots to bring messages and take back cables from Washington. That way, the Japs wouldn't hear fleet radio working in this area, and they'd have no chance to decode secret orders. But the admiral got wind of some queer business up around the mandated islands north of here. I don't know what he heard, but the fleet sailed up that way five nights ago, keeping out of sight of the islands. That's when they flashed word to Washington to rush you and Doyle out here because you were familiar with most of that area."

"Any carriers with th' battlewagons?" grunted Doyle.

"There's at least one back in the second line, with a destroyer and sub escort. But they're still south of Guam, waiting for emergency orders to dash for the Philippines. The rest of the scouting force is spread out in an arc between the Fleet divisions and Japan."

"Whether it's war or not," said Knight, "the Japs have discovered some powerful weapon when they can cut off radio communication."

"And the worst of it," groaned Weldon, "is that the fleet won't know that we've lost contact. All radio rooms have been sealed to avoid the chance that some spy in the fleet might tip off the Japs and to keep fake orders from causing trouble."

"There's only one thing to do," decided Knight. "Lothario, we've got to find the fleet and tell the admiral what's happened."

"It's jake with me," said Doyle. "I'll go tell 'em to load those guns again."

"They're already reloaded," interrupted Weldon. "I gave the crew-chief orders, in case there was another attack."

"Then what are we waiting for?" rumbled Doyle.

"We'll take this map, Governor," said Knight. "If the fleet's heading for Tainen, it will be easy to intercept it on a line from this last position."

"I'll give you the recognition signals," said Weldon. "You'll have to use blinker, of course. Miller was assigned to the flagship, the *Pennsylvania*. You won't have any trouble landing alongside, once they've okayed your signal—"

"Perhaps Mr. Knight will find it

simple," a sibilant voice came suddenly from the doorway. "But permit me to doubt it."

KNIGHT PIVOTED swiftly, right hand raised toward the gun inside his coat. He had a split-second glimpse of a mocking brown face, of teeth bared in a mirthless smile. Then a tiny flashlight affixed to an automatic jabbed a beam of light into the room and everything was blotted out.

"Don't move, if you please," the Japanese said softly. "It would be better, Governor, if you do not touch the telephone."

"Why, you dirty rat!" fumed Doyle. Knight heard the scrape of his shoes as he started to lunge.

"Get back, Lothario!" he said swiftly. "I know this devil—he'll kill you."

"Thank you, Mr. Knight," the Japanese said politely. "It is a pleasure to find that you have not forgotten my humble self."

"The pleasure is all yours," Knight said grimly. "I'm sorry to learn my aim was so poor that night in Shanghai."

"Your aim was excellent, Mr. Knight. Fortunately, a knife-sheath deflected the bullet from my heart. But the scar remains, to remind me of you."

Under the purring voice there was a note of hate. Knight kept his eyes open, enduring the stabbing pain the light caused him, although he could not see a thing.

"Whatever you're up to, Misaki, you won't get away with it. Just remember that this is an American island, before you start shooting."

Misaki laughed softly. "But I have no intention of shooting—now."

"You'll hang for this!" grated Weldon.

"You are too optimistic, my dear Governor," said Misaki. "I came here to make certain our plans had succeeded. You and Mr. Knight made my task quite easy; in fact, through your discussion I know even more than I expected to learn."

"It'll do you no good!" Weldon said furiously.

"On the contrary, it will serve me perfectly—and my country."

Knight's thoughts traveled back to the minutes before Misaki's appearance. He had glanced toward the door as Weldon began his explanation about the Fleet. There had been no sign of an eavesdropper then. Misaki must have missed the first part of the conversation.

"You're too late, Misaki," he said with studied coolness. "We already know the secret of Tainin Island."

"You're lying," the Japanese said sharply. "I overheard the air-station manager talking about Stapleton's warning—" he checked himself abruptly. "Ai! You are up to your

clever tricks again, Mr. Knight. But it will do you no good. I am aware that everyone was mystified by the voice, as well as my pretty music."

Knight heard him step closer as he continued. "Turn to the door, my dear Governor. And you with the baboon face."

"Why, you blasted ring-tailed monkey!" snarled Doyle. "I'll show you who's a baboon—"

"Lothario!" Knight hastily cut in. He moved to place himself between the two men, with the sound of Doyle's fuming voice to guide him. His hands were half-lifted, so that Misaki would not fire, but the Jap's sibilantly indrawn breath told him that the man was on edge.

"Turn around!" Misaki ordered. Knight felt the brief prod of the gun against his back. It had worked! Weldon and Doyle were ahead. The beam from the pistol-flashlight was at his back. In another moment . . .

"Listen carefully!" Misaki said in a tense voice. "There are men outside who might stop me. But you

ows. "We just discovered one of our men unconscious from a stab wound down by—"

"I've no time for that now," Weldon said gruffly. He pushed on by. Hall stared at him in amazement, caught his arm.

"But, Governor, this man—"

Knight saw Misaki's black eyes dart apprehensively toward the approaching airline mechanic. It was only an instant that Misaki's eyes were turned away, but it was the moment for which Knight had waited. His stiffened right hand whipped down with hammer-like force onto Misaki's wrist. The gun roared, drilled into the ground. Before the stunned Japanese could shift it from his nerveless fingers, Knight wrenched it away.

HALL HAD sprung back as the gun blazed. He hurtled against Doyle and Misaki scrambled free just as Lothario dived for him. Knight was momentarily blinded by the flash of the pistol. When he could see again there was no trace of the Japanese.

"Where is he? Which way did he go?" bellowed Doyle.

"He ran toward Cable Station road," exclaimed the airline mechanic.

"Get up there after him!" roared Weldon.

"He's not headed that way—I can see the road," broke in Knight. "Either he made for the beach or he doubled back through the station."

"If we only had lights!" said Weldon. He stopped as a shrill whistle sounded from somewhere along the beach. A moment later an engine thundered to life. Knight ran toward the beach, saw a Kawanishi 95 two hundred yards to the

left. It had been drawn up under overhanging palms at the edge of the shallow reef. A helmeted figure was bent over in the rear cockpit, and he saw Misaki run alongside, clamber up into the front pit.

"Too late to stop him!" he shouted as Doyle caught up. "But we might be able to knock him down if that OS2U-1 is ready."

With the beach as a short-cut, they reached the ramp in a few seconds. The Navy mechanics were staring into the gloom as the Jap seaplane taxied out through the shallows.

"Twist her tail!" Doyle howled. "Here comes the night-shift!"

Knight vaulted into the pilot's seat, threw the switch. The engine caught instantly and he sent the ship trundling down on the dolly. They were almost to the end of the channel when Knight saw the Kawanishi swing back after a hasty take-off. He gunned the Vought-Sikorsky into clear water, sent it ploughing ahead. Just as the step lifted from the choppy waves, the Jap ship plunged down,

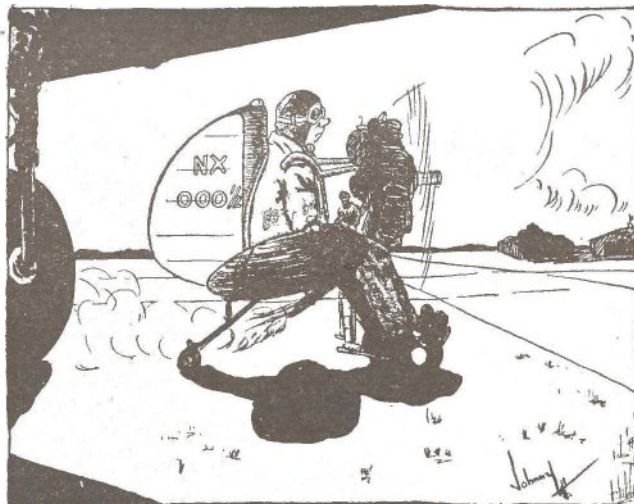

"I would be a test pilot—phooey!"

three will see that I pass them safely. It will be quite simple in the dark. You will tell them you have no time to talk, Governor Weldon, if they attempt to stop you. I shall be here behind you, with my pistol against Mr. Knight's side. At the first sign of trickery, I will kill him and then shoot both of you. Is that clear?"

"Clear enough," Knight said ironically.

"I hope I shall not have to underline it with bullets," Misaki said softly. "Now walk toward the door."

Knight's peculiar dark-vision had begun to return, but the effect of Misaki's flashlight still made his eyes water. He heard a faint click as the light was switched off. Ahead, Weldon and Doyle were moving slowly through the doorway. Doyle's head was slightly turned, a savage look on his battered features. Just as the group emerged in the darkness, Hall and one of the airline mechanics came along the palm-lined walk.

"Governor Weldon?" Hall said quickly, peering through the shad-

its guns winking redly in a warm-up burst. Knight shouted a warning back at Doyle, and the rear-pit 30's blazed up at the Kawanishi.

CHAPTER III

TAINEN ISLAND

MISAKI'S TRACERS had been stabbing wildly through the gloom, but as Doyle fired the Jap swiftly corrected his aim. Knight ducked as a blast nicked the already riddled enclosure. The Kawanishi swept by, pulled up in a chandelle. Knight had held the scout-bomber close to the water to gain extra speed. With a furious zoom, he hurled the ship up at the Nipponese plane.

A fusillade from the Brownings flamed close to the Jap ship's tail. Misaki skidded frantically, almost stalled. Knight had his guns aligned for another burst when a flare blossomed under the Kawanishi. The stick jerked as Doyle seized the controls, and Knight bent down, shielding his eyes from the glare.

The blinding glow faded abruptly, and in a few seconds Knight could see. He looked hurriedly around the

sky. The Kawanishi was fleeing northward, climbing steeply toward the clouds.

"I'll take it," he shouted at Doyle. He sent the ship thundering after the Kawanishi, but the lead was too great. The Jap seaplane disappeared in the clouds before he could get in firing-range. He climbed up into the chill, moist depths, found clear air above the clouds, at 7000 feet. But there was no sign of Misaki.

"Any luck?" Doyle rumbled, through the intercom.

"No, he's probably flying on instruments, hoping to shake us off. We'll follow the course to intercept the Fleet and maybe we'll spot him again."

"That flare popped right in my face," growled Doyle. "I was as blind as you were or I'd have nailed him."

"Don't worry about it," said Knight. "Unless we could have forced him down alive, it wouldn't have done us any good. It's my fault for not catching him back at the station. It's obvious he knows the whole set-up and we might have made him talk, although he's got fanatical courage."

"I remember when you tangled

with him. I was in the hospital, after that scrap on the Bund. But I didn't know he was a hot-shot for Jap Intelligence."

"He's no ordinary spy," replied Knight. "I think he was a free-lance then, trying to work himself into the graces of the Kimitsu Kyoku. He seems to have done it."

"You think that was th' ship that got away in the first scrap?"

"Probably. He must have climbed up so he could make a long dead-stick approach. There were enough lights left so that he could tell where the harbor was—we might even have guided him in with that extension-light they had on the ramp. The surf would carry them in over the reef to shallow water, and it's not far from that inner reef to where the plane was hidden. Misaki's gunner could have waded the last little way and pulled the ship ashore."

"Misaki had nerve, bargin' in there like that," Doyle said grudgingly. Then his tone changed. "Baboon, eh? If I ever lay my mitts on that bird—"

"Take over," Knight interrupted. "Hold her on due north till I work out a course to intercept the Fleet."

The two-seater droned along for two or three minutes, then Knight looked up from the map.

"The course is 342, assuming the Fleet's making eighteen knots. That's what Miller had marked down here."

"That's almost th' course to Tainen, ain't it?"

"Pretty close. I'd give a lot to know what makes that island so suddenly important. It was absolutely deserted the last time I saw it." He stopped short, looked back under the bullet-torn enclosure. "Stapleton! Why didn't I think of that, after Misaki let it slip?"

"Who's Stapleton?" demanded Doyle.

"Old Jonas Stapleton, the fellow they used to call the 'Wave-length Wizard.' Invented a radio relay for remote-control work, and some corporation grabbed it — or so he claimed."

"Sure, I remember him now. Got arrested for trying to kill the president of the company. I thought he was still in jail."

"He got off. I thought he went to South America—anyway he left the States. But it's a hundred to one he's the man Misaki meant. It begins to add up. That warning, to keep away from Tainen—"

"Yeah—'all mine,'" said Doyle. "But wait a minute, there's something screwy about that. If th' Japs are in on it, he wouldn't be the lead guy."

"Well, we ought to know before tonight's over," Knight said grimly. "Unless all the signs are wrong, the Fleet's closing in on Tainen."

DOYLE GLIDED through the clouds into the clear air beneath. There still was no trace of the Kawanishi. Over to the east he could

Obey That Hunch!

by Manuel Buaken

I WAS conducting a one-ship flying school just outside Los Angeles. It was a drowsy day and I was napping a bit in the back of my car, when Art Stevens woke me up.

"I've about three hours flying time left of my course," said Art. "I'd like to take it all at once. What do you suggest?"

"Well, Stevens," I answered. "I think you need practice in landing. Let's just hop around, make a set-down here and there. I want to chin a bit with Bill Hardesty over at Santa Monica. We'll head there first."

At Santa Monica, Bill was a little absent-minded as he greeted us. "Wish you'd made it another day," he said. "I'd have more time to chew the rag. There's a big party of movie people going out in a new type ship and I have a chance to pilot it."

"Stick around," I urged him. "I've got an important proposition to make you." I didn't really have a thing to say to him. I was just stalling. I didn't know why. I had nothing at all to say, but something urged me to keep him from taking that ship out.

After I had exhausted all the gossip about our old gang (we had worked on a flying outfit together) Bill dashed away. In a few minutes he was back, cursing. "You made me miss a chance to fly that new ship!"

"You couldn't fly that crate anyway," I kidded him.

Bill grumbled sourly, but for some reason I didn't seem to mind his annoyance. "Go on, peddle your papers," he snapped at me. So I took-off with my student. We had been in the air only a few minutes when I saw a black cloud in the air in the direction of Santa Monica.

It reminded me that I had seen another such black cloud when the Question Mark, making an endurance flight, had been forced to unload extra gasoline. It had made a black cloud that was there and was gone.

I thought idly, "But the Question Mark isn't in the air any more." And the whole matter slipped my mind. With my student, I completed the schedule for the day and it was dark when I drove to my home in Los Angeles.

I heard an extra being called, casually bought one. And there in screaming headlines was the story of the death of ten people, people prominently connected with the movie industry, in a collision of two planes that took-off from Santa Monica that afternoon.

So I had saved my friend, Bill. By that aimless talking, impelled by an urge too strong to resist, I had stalled Bill so long he missed that ship of death.

And so I say: Obey that hunch!

just make out Rota Island, first of the Marianas extending northward toward Tokio. The plane cruised smoothly over the desolate sea, through a sky that to Knight's eyes was as clear as though it were the gray of approaching dawn. For the next two hours, Doyle and he alternated on the controls. He was relaxing, eyes closed, with Doyle at the stick, when his partner's excited voice suddenly boomed through the ear-phones.

"Hey, Dick! Looks like a battle up ahead. I can see flashes that look like big guns."

Knight sat up, stared over the cowl. Less than ten miles away two columns of gray battleships were speeding north, the guns of the leading vessels intermittently blazing. The glare blurred his vision momentarily, then he saw the target. Two huge cruisers, foreign in appearance, were fleeing from the American ships. Their main guns were dark, but occasional shots from their smaller batteries kept the Navy destroyers and light cruisers out of range.

"Weldon was right!" Knight said tensely. "It's war! The Navy's flushed out two Jap cruisers—tough-looking babies, too."

"A full-scale row and I can't see a thing," groaned Doyle. "I'd give my right arm to see those Jap ships blown out of the water."

"There's something queer about this," said Knight. "Those Jap ships look fast enough to shake our dreadnaughts, maybe even our cruisers. If they're the ships Miller saw, they could have escaped three or four hours ago."

"Which way are they headed?"

"On a dead course for Tainen. It can't be more than twenty miles. There it is—I can just see it through the smoke from the first Jap cruiser."

"Anything look wrong about it?"

"Can't tell. But this looks like some kind of a trick. I'm going to drop down near the flagship. Get out that blinker tube."

The Vought-Sikorsky swooped down over the gray battleships. A searchlight flickered up, probed at the descending plane. Just as Knight let go the controls for Doyle to take over, the ship trembled under a lash of machine gun fire.

"Hey you fat-heads—" Doyle's howl changed to an oath. "It's Misaki!"

"Lead him down for the gunners to pick off!" shouted Knight.

The scout-bomber screamed into a brief dive. Knight felt it pull but with a lurch that took the blood from his head. His sight gradually returned. He flung a look back at Doyle.

"Did they get it?"

"No, th' crazy bums started pourin' it into us! Must've thought we were Japs. But one of th' destroyer gun-crews woke up and went to work on the Kawanishi. I think they hit it—looked like smoke comin' from th' cowl when he flew through a searchlight."

"Where's the blinker tube?"

"It fell under my seat. Must be back in th' tail."

"We'd probably get another blast if we came down again to signal them," said Knight. "We'll make for Tainen. If we find the Fleet's running into a trap of some kind, we'll at least know what to warn them about."

Anti-aircraft guns on the Jap cruisers blazed away at them as they climbed. Knight zigzagged and was soon out of range. In a few minutes Tainen showed plainly below them. It was about seven miles long, not quite two miles across. Except for a hilly spot near the southern tip, it was barren and sandy with a few

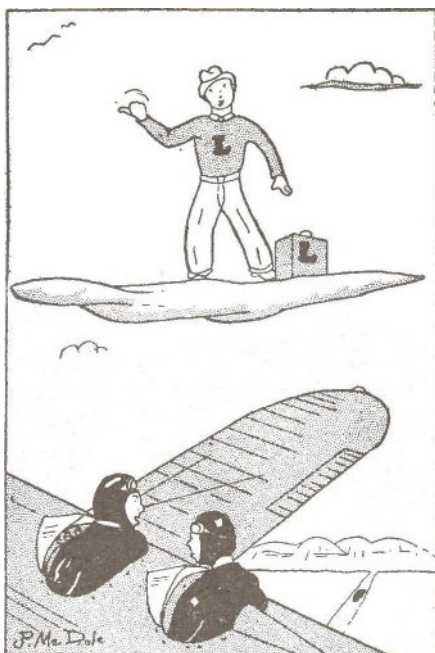

"Can't that college guy see there's no room?"

broken palm trees to show where a typhoon had some time ago denuded the island of its normal growth. The hill at the southern end was thickly covered with palms which extended clear to the edge of a sheltered cove.

Between two and three miles to the west, a long reef ran parallel with the island. Knight glanced at the map, saw that there was a quick drop to deep water, both at the shoal and the island, with a maximum middle depth of 650 feet. As he looked back at Tainen, a small structure became visible through the palms near the cove. He closed the throttle, nosed down.

"See anything?" queried Doyle.

"There's a house and a shed of some kind that weren't here before. And I just spotted a Kawanishi drawn up under the palms."

"Misaki?"

"I don't think so. He couldn't have made it that fast, even if you were wrong about his ship being crippled."

Knight switched off the engine, put the seaplane in a gentle forward slip. Fifty feet from the water he ruddered into a slip and then set the machine down a few yards from

the beach. As it slowed, he swung the nose shoreward and the pontoon grounded. In another moment Doyle and he were alongside the Kawanishi.

"It's not Misaki's ship," said Knight. "There's not a bullet-mark on it and the insignia's a little different."

"I was hopin' it was his," Doyle said in a disappointed tone. "I'd like to meet up with—what's that?"

A muffled harmony was briefly audible, as though a door had somewhere been opened. A faint thud followed and the weird music ended.

"We're getting close to the answer," Knight whispered. "Get back of the Jap ship! Someone's coming!"

They had barely dodged behind the Kawanishi when a Japanese petty officer appeared from the shed under the trees. A holstered pistol hung from his belt.

"Misaki!" the Nipponese said eagerly as he approached the Vought-Sikorsky. Then he stiffened and Knight saw the startled look on his brown face as he realized it was not a Kawanishi. Knight's .38 was already out of its shoulder-harness. He stepped out silently, knowing the petty officer could not see him in the shadow of the plane.

"Hands up! *Hayaku!*" he ordered in crisp Japanese.

The petty officer whirled, made a frantic attempt to draw his pistol. The butt of Knight's gun thudded down on his head and he fell without a sound.

"Did you finish him?" Doyle muttered, staring down through the darkness.

"I don't know. But he won't bother anybody for the next hour or two, I'll guarantee that. Come on, we've got to find out what they're up to."

The door to the shed was open. Knight looked cautiously inside.

"The place has been stripped," he whispered. "Looks as though it might have been a workshop. Let's see what's in the house."

An open window revealed most of the interior to Knight's super-sensitive eyes. The main room was scantily furnished with rattan chairs and tables. He saw two bedrooms and a small kitchen, but there was no one in sight. He was turning to skirt the building when he saw a steel tripod mast not far away. It had been erected on a huge wooden turntable; a similar mast was built at the opposite rim. He looked up, saw strips of bright metal extending between antenna-spreaders.

"What's up?" Doyle said in an undertone.

"There's some kind of freak antenna out here on a turntable. I can see a drum-and-cable system for rotating it—the cable leads back to the base of the shed."

"Then they must work it from underneath," hazarded Doyle.

Knight led the way back into the shed. A more careful survey disclosed a counterweighted trap-door behind a packing case in one corner.

"Have your gun ready," he told

Doyle in a low voice. He stooped, cautiously lifted the trap. Steps led down to what appeared to be the doorway of a large concrete dugout. He could see only to the entrance, for the light inside made the rest a dark blur. From somewhere in the dugout came the muffled, eerie music they had heard before. Above the unvarying harmony a shrill singing voice, obviously that of a Japanese, was talking in English.

"You will not have long to wait, my smart *Amerika-jin*. When Misaki arrives, you will wish you had died before trying to give that warning."

"You brown devils!" said a voice harsh with fury. "You're nothing but cowardly rats—afraid to come out in the open and fight."

There was a vicious smack, as though the speaker had been struck in the face. Knight swore under his breath.

"Sneak down there and see what the layout is," he whispered to Doyle. "Spot the lights. We're going to take a quick hand in this game."

DOYLE brushed past Knight. There was a groan from inside the dugout and the unseen Japanese laughed shrilly.

"So you do not like that, Mr. Stapleton? It is only a hint of what will happen to you—and any of your countrymen who live through the next half-hour."

"You'll never get them all," rasped the other man. "The ones that are left will finish those cruisers—and they'll get you, too! God help you when the bluejackets do find you."

"You speak like a fool," sneered the Japanese. "Every ship will be destroyed—thanks to your clever brain. And the rest of your Fleet will be finished the same way, if the United States meddles in our affairs."

"Commander Nikki," a new voice said in Japanese, "the first cruiser is but twelve miles from the shoal, by the sound-detector dial."

"Have no fear, Misaki will be here in a moment," said the shrill-voiced Nipponese. "He is probably starting the other Kawanishi before coming to get the master-relay."

Doyle came up the steps, put his lips to Knight's ear. "It's a big place filled with dynamos and a lot of electric gadgets. But there are only three Japs. One's a navy three-striper and the others are petty officers. They've got Stapleton tied to one of the girders that hold up the roof."

"Are they armed?"

"Yeah, all three of 'em. The light switch is about ten feet inside the door. Better let me jump 'em and shoot it out with th' rats."

"No, we'll use the old system. You go for the switch—I'll be all set."

"And then I stand there and twiddle my thumbs," Doyle said with disgust. He went back down the steps and Knight tiptoed after him, with his eyes closed against the light from the dugout.

"Here goes!" Doyle whispered. Knight tightened his grip on his

pistol as he felt Doyle move away.

Suddenly a wild cry came from inside. "Commander Nikki—a white man with a gun!"

A pistol roared and someone screamed. Knight sprang blindly through the doorway, his automatic lifted. Two more shots blasted from across the unseen dugout. He triggered a swift answer, aiming in the direction of the sound, and a groan followed. A splinter of wood gashed his face as a third shot rang out. Then the darkness miraculously lifted as Doyle switched off the lights.

CHAPTER IV

STAPLETON'S STORY

KNIGHT LUNGED to one side, swinging his gun toward a blue-clad figure a few yards away.

"Drop that pistol! *Hayaku!*" he snapped.

It was the three-striper, Nikki. The officer jumped back, fired desperately at the man he could not see. His finger was jerking the trigger for a second shot when Knight dropped him with a bullet through the heart.

A chunky Jap petty officer lay sprawled beside a workbench half-

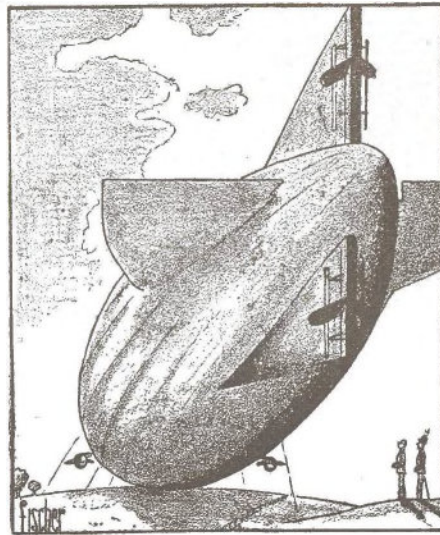

"Yes, I won it in a radio contest!"

way across the dugout and another Nipponese was hanging onto his right arm as he tried to find the exit in the dark.

"Stand where you are!" Knight ordered sharply in Japanese. "Drop that knife!"

A look of amazement crossed the face of the wounded man. The dagger he had unsheathed clattered to the floor and he gaped through the darkness toward Knight.

"Lothario, are you all right?" Knight asked quickly.

"Sure—but I don't like this black-out. One of those birds is liable to take a potshot in the dark."

"No chance," said Knight. "Nikki's done for. One of the petty officers is dead and the other's got a bullet through his arm. I've got him covered."

"Thank the Lord!" said a shaking voice, and Knight saw the prisoner for the first time. Stapleton was bound to the upright girder with control-wire cable. His graying hair fell down unkemptly over his face, but Knight saw the ugly welts there.

"We'll have you loose in a minute," he said. He picked up a pair of pliers from a workbench, without taking his eyes from the wounded petty officer. "Lothario, take these wire-cutters—you'll have to get him loose in the dark. We'll tie up that other Jap the same way."

"Turn on the lights!" Stapleton said urgently. "He's likely to escape in the dark."

"I can see in the dark," Knight told him. He herded the frightened petty officer across to the pillar as Doyle freed Stapleton. In another minute the Japanese was securely bound.

"Misaki—what happened to him?" Stapleton said hoarsely.

"I think his plane fell in the ocean," said Knight. He flicked a quick glance around the underground workshop, at the purring dynamos, at a device that looked like an organ with coils at the top of each pipe and a battery of microphones in front. Above the ceaseless, monotonous harmony that came from the apparatus there was a sudden new sound, the rumble of big guns.

"The fleet! It's begun!" Stapleton gasped.

"Then they're in danger?" Knight demanded.

"No—not now, thanks to you two." Stapleton wiped away blood that dripped from a bruise on his cheek. "It was a trap—but with Misaki and Nikki gone, they're safe."

"What was it?" Knight said swiftly.

"Radio-exploded mines," Stapleton mumbled. "It's my fault. But I never dreamed it would lead to this, when I came here—"

"Wait—what about these mines? Where are they?"

"THEY'RE planted between Tain-en and the shoal, hundreds of them. But they can't be exploded by contact. They're set to float just under the depth for a dreadnaught—when the relays are actuated, the mines drop a small ballast-load and come up, and three seconds later they explode. They can be set off from here or from a master-control plugged into a special transmitter in a plane."

"Holy smoke!" said Doyle. "If the Fleet ever got in there the Japs could wipe out every ship between the island and the shoal!"

"That was the plan—for the two Jap cruisers to start a fake war and lure the American divisions into chasing them into this mined area. The Kimitsu Kyoku agents knew all about the Navy's secret maneuvers the day the Fleet left Pearl Harbor. They planned this months ago. They knew our Navy would be coming to aid the British if Japan attacked in the Pacific."

"This 'fake' war," broke in Knight.

"What do you mean by that?"

"They're using my radio-block to keep all communications cut off in this area," Stapleton said wearily. "It's a radio echo system using powerful frequencies beyond the range of ordinary receivers. The frequencies have multiples that echo down through the standard and short-wave bands and neutralize all signal-strength. I found out that a combination of the musical notes in both major and minor scales, would create 'echoes' enough to drown out all frequencies now in use. But they also start tonal vibrations in filament lamps—the way even plain house-lamps sometimes get resonant with ordinary radio frequencies."

"We had a sample of that at Guam tonight—along with a color-change act," said Knight. "The radio was blotted out."

"I tried to send a warning to stay away from Tainen—that it was all mined," Stapleton interrupted. "Nikki almost killed me. He would have if he'd been sure Misaki didn't need me any more. They've kept me a slave, made me teach them how to blot out an area with a directed beam. When I came here, I was only trying to perfect it and sell it to the U.S. Government for war-use. I hid on this island because my other invention was stolen. But the Japanese found out, when I blanketed some of their island stations. They tracked me down, then built this underground laboratory and brought in engineers to build my radio-control sets for their mines."

"I don't get all this," blurted Doyle. "Why didn't the Brass Hats on those battlewagons think it was queer when they didn't hear any radio at all—not even commercial stuff?"

"You forget they sealed the radio rooms," said Knight. "Even if they did use them, they'd probably think that all American and Asiatic stations were off the air because of the war."

"Maybe so—but what about their hearin' all that screwy music and th' lights actin' up?"

"It won't touch them, until they're directly in line with one of the directive-beams," explained Stapleton. "One beam is aimed straight at Guam, and the other, through a remote-control turntable across the island, makes a radio-block or wall between the Fleet and Asia. Everything between the beams is simply a dead area, cut off from radio communication. Even if the Navy operators tried to get through later with S O S calls, nobody could hear them. The Japs are even planning to put sets on warships, so they can try the same trick anywhere. But thank Heaven that'll never happen now. They never could build the transmitters without me."

"And we're wrecking this one right now," Knight said grimly, "after we cut off the control for those radio-mine relays."

"Whatever you say," Stapleton agreed dully.

Aero Book Reviews

Any volume described in this department may be obtained, at the price quoted, direct from the publisher named and at the address given. When writing for a book kindly mention that you saw it reviewed in FLYING ACES.

For Model Makers

Building and Flying Model Airplanes, published for Air Youth of America by D. Appleton-Century Company, 35 West 32 St., New York City, \$2.00.

For the novice model builder this book is worth its weight in gold. A broad statement, no doubt, but nevertheless it is an edition that will serve the purpose for which it was intended. Accurate, up-to-date, with photographs, diagrams, and helpful hint sketches, it has all the necessary ingredients that go to make up a worthwhile model airplane manual.

Prepared by a host of experts with many years experience in the field, the book describes in detail every step required to build a successful model, whether it be an ROG stick or a six-foot gas job.

Subjects dealing with the relationship between real aircraft and model planes, materials, tools for model building, selecting and grading balsa, metal fittings for rubber and gas jobs, in fact everything the beginner would want to know, may be found here.

The material in the book is basic to the Air Youth program for clubs and groups that desire to participate in junior activities. But the emphasis has been placed first in mastering the fundamentals through building a series of elementary models typified by the first five Air Youth projects.

The technical information on which the volume is based has been developed largely by Arthur

(Also see pages 72 and 78 for other reviews)

Vhay, Technical Director of Air Youth. An outstanding feature is the many life-like sketches showing methods of procedure, shaping metal fittings, covering, doping, and rib cutting. A flight chronology and the latest glossary of aviation terms round out this book as the best value of which model builders can take advantage.

Training on Paper

Let's Fly, by Ernest G. Vetter, U.S.N., William Morrow & Company, 386 Fourth Ave., New York City, \$1.50.

Let's Fly is a little book, but a colorful one. Profusely dotted with line drawings that illustrate the Chinese proverb. "One picture is worth a thousand words." it takes the student-reader right into the cockpit in such manner as to make him feel as if he belonged there all the time.

First, he is told why an airplane flies. Then, without realizing it, all his unasked questions are answered. On the ground or in his easy chair, the reader is made to feel he has the aircraft controls in front of him. Automatically he is inspired to go through the motions of a take-off, climb, leveling off, a turn, and a gentle glide to a perfect landing.

Let's Fly was not written to actually teach one to fly. No book can do that. But this little handbook can, and will, take you in your imagination through all the requirements of flight training.

Technically correct and based on the CAB's course which is being given to thousands of civilians this year, it yet retains a certain flavor and informality of a living experience.

Lieut. Vetter, of the Naval Air Reserve, is a flight and ground instructor as well as a commercial pilot of many years experience.

"Where's the switch for the mine control?" queried Knight.

"It's not on the main switchboard," said Stapleton as Knight started to guide him across the dugout. "It's in a special chamber with an independent power system. The door's at the other end of the laboratory."

Knight took a quick look. The door was made of steel and he could see two heavy locks.

"Nikki has the keys," Stapleton said, before Knight could ask him. "He'd already switched the circuit for the master-control in that Kawanishi outside. Misaki was to have set the mines off from the plane, when he saw all our ships were in the mined area. If he didn't get back in time, Nikki was to set them off from here, with a spotter out on the beach to tell him when it looked like the right time."

"We've got to work fast," Knight rapped out. "I'm taking no chances that some of those mines are high enough to be hit. They might go off, even on contact. Lothario, switch on the lights. Stapleton, you get the keys from Nikki and turn off that circuit, and cut off your radio-block dynamos. I'll get out to our ship and start the engine, so I can radio a warning to the Fleet."

THE LIGHTS clicked on as Knight reached the doorway. He felt his way out to the steps, was starting up them when the sound of tense breathing made him jerk back.

"Knight!" snarled Misaki's voice. A furious blow sent Knight headlong and he lay dazed at the foot of the steps. He heard another voice, and someone leaped over him.

"Doyle—it's Misaki!" he heard

Stapleton scream.

A pistol roared and Stapleton's cry died into a groan. Another shot boomed through the dugout, was followed by three more. There was a crash from inside the laboratory, and another flurry of shots.

"The keys!" screeched Misaki. "I'll keep the American off!"

Feet thudded on the concrete floor. Knight heard Doyle rasp out an oath, and two more shots rang through the underground workshop. Then someone stumbled over him.

"The plane! We'll take care of that fool later!" Misaki cried hoarsely. Knight pulled himself up, tried to see through the glow from the dugout as the two Japanese ran up the steps. But everything was dark.

"Dick—I thought those devils had killed you!" Doyle's voice came, panting, from the blackness. Knight got to his feet with his partner's help.

"Banged my head against the floor," he said thickly. "Help me up the steps—we've got to stop them!"

"They shot Stapleton—got the keys," Doyle said savagely as they went up into the abandoned shed. "I winged the bird with Misaki, but he turned a workbench over and dropped behind it so he could grab the keys—"

"It's my fault for not keeping guard," muttered Knight. His vision returned as they went out into the darkness. "Poor old Stapleton . . . but we can't think about him now. With the control-set in that Kawanishi, they can still blow up those ships!"

Misaki and a stocky Japanese were starting up the control-plane. Knight saw the spy's dripping trousers, his bare feet and torso. It was plain now that the other Kawanishi had been downed. With fanatical determination, the two Nipponese had swum to Tainen to carry out their scheme.

Knight fired as the seaplane's engine kicked over, but the lurch of the ship took Misaki out of the bullet's path. Before he could fire again, Misaki opened the throttle and the plane thundered away from the beach. Sand and foam whirled back as Knight and Doyle reached the Vought-Sikorsky.

Seconds later, as the two-seater roared out after the Kawanishi, Knight flung a hasty look across the water. The Jap cruisers, huge, menacing, had already passed that point, and the first American ship was less than two miles from the mined area. Searchlights from destroyers intermittently flashed ahead to spot the shore at Tainen and the surf that marked the shoal.

Knight narrowed his eyes, took-off half-blind. The Kawanishi was climbing steeply, but the scout-bomber was faster. Knight kept the throttle wide open, his eyes grimly fixed on the Jap plane. A searchlight swept across the mined waters a thousand feet below. Knight saw only the glow on the surf, but his vision blurred for a moment. A shout from Doyle gave him warning just as Misaki's gunner opened fire.

TRACERS BLAZED through the Vought-Sikorsky's wing. Knight zoomed, thumbed his stick button. A lethal blast from the Brownings flamed across the other ship's tail and the gunner slid half-way down in his seat. Knight thought he was finished, but with a desperate effort the man drew himself up, fired a last burst.

With a furious roar, the Vought-Sikorsky's prop went to pieces. Knight cut the switch before the unburdened engine could rev up.

"Get your belt open!" he shouted to Doyle. "Bale out—try to warn them—"

Doyle's answer was lost in the scream of the plane's wings. Misaki had dived to one side. Knight plunged after him, whipped the crippled seaplane into a vertical as Misaki tried to reverse. The Kawanishi seemed to leap out at him. He tightened the

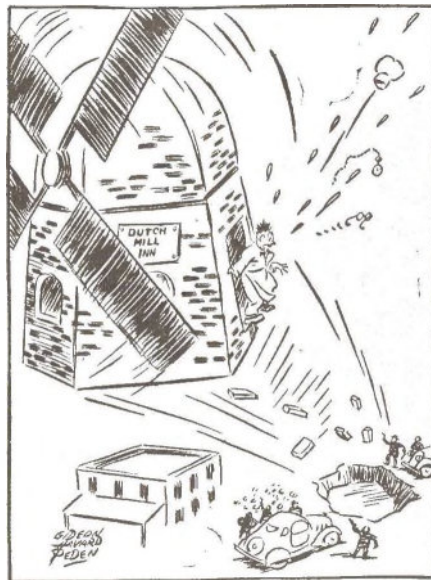

"Yeow! Too many revs on her!"

turn to keep parallel with the Jap plane. There was a taut instant when he thought his mad plan would fail. Then the scout-bomber's wing knifed into the Kawanishi's struts and the two ships rammed together.

From the corner of his eye, Knight saw Doyle go tumbling down, hurled out by the impact just as he started to jump. Misaki's stunned face glared across the tangled wreckage. Knight jerked his belt open, clawed his way toward the Japanese as the interlocked ships began to fall.

A frenzied look raced across Misaki's face. He reached down and grasped a black box with a switch and rheostat plugged into the instrument board. Knight's hand shot out, seized Misaki's arm before he could break the connections. Below, as the tangled planes began a flat spin, he saw the Japanese cruisers nearing the northern tip of the island. The American ships were a mile from the mined waters.

With a wild cry, Misaki let go of the radio-relay and snatched at a signalling-pistol clipped at the side of the cockpit. Knight flung himself

down, gripped the rheostat and switch.

A tremendous roar came up from the water below—a series of thundering explosions as though from a thousand cannon.

The roar of the exploding mines ended and Knight found he could see again. He caught at a center-section strut, pulled himself up.

The swirling water was only a hundred feet below. He had barely time to put his arm before his face when the spinning planes struck. The water closed over him and a tangled wire caught him as he tried to come up. He pulled free, fought his way up through the litter of wreckage.

Misaki was crawling up onto the Kawanishi's crumpled wing. Suddenly he stopped, like a man turned to stone. Knight followed his gaze, saw the two Jap cruisers through a pall of smoke. Flame was just starting to roll up through the smoke. The first cruiser heeled over, was sinking by the bow. The other had rammed into it, and it too was sinking.

With an anguished cry, Misaki turned. Suddenly he bent, grasped the jagged remnant of a strut fitting. The sharp point plunged deep into his stomach, raked sidewise. A single groan escaped from his lips, then he toppled into the sea.

* * * *

"SO MISAKI bumped himself off?" asked Doyle.

Knight gazed across the water, from the quarterdeck of the *Pennsylvania*. It was still dark.

"Yes, he committed hara-kiri," he said slowly. "It wasn't very pretty. I'd like to forget it."

"There's plenty I want to forget about this business," grunted Doyle. "And one of 'em is how close some dumb gob came to turnin' me into a sieve when I slipped that chute to drop on board here. Said he thought I was a Jap chutist with maybe a couple of bombs. Just like a gob."

"Just the same, Leatherneck," said Knight, "the Navy came in pretty handy tonight."

"You notice who they sent ashore for a landing party," retorted Doyle.

They both turned as the signal officer came toward them, peering through the gloom.

"I'm looking for the admiral, Mr. Knight. Have you seen him?"

"I think he went back to the bridge. Any word from shore yet?"

"Yes. A blinker message just came through. They found Stapleton dead, but he must have recovered his senses for a few minutes after you left the dugout. He'd wrecked that radio-block transmitter."

"Poor old fellow," muttered Knight. "Carried out his part, even when he was dying, so we could warn you by radio. If I'd only known—but I didn't."

"We'll never know the secret of that device now," said the signal officer. "But, at any rate, the Japs won't have it, either. And they've lost two cruisers. They won't dare say

PLANE TALK

SKYWAY SAVINGS ON ALL SUPPLIES

SPECIAL!

Complete outfit—famous Syncro B30 or Sky Chief motor—and your choice of any \$2.95 kit, all for only \$9.90 P.P. We Sell all kits, gas motors, supplies.

- 18" Balsa Strips Select. Hard Stock 1/16 sq. 60. 5c 1/16x3/16 35 for 5c 1/16x3/16 18. 5c 1/16x1/4 16 for 5c 3/32 sq. 30. 5c 3/8 sq. 30 for 5c 3/8x1/16 12 for 5c 3/8x3/4 10 for 5c 3/16 sq. 8. 5c 3/8 sq. 6 for 5c 3/4 sq. 3 for 5c 18" Balsa Sheets 1/64x2 6 for 10c 1/32x2 9 for 10c 1/16x2 8 for 10c 3/32x2 7 for 10c 3/8x2 6 for 10c 9/16x2 3 for 8c 1/4x2 .3 for 9c 1/2x2 .2 for 11c 3" x 36" cost twice 18" 3x36, 4 times

- 5 FOOT Balsa Minimum 50c 3x3/16 10 20c 3/8 sq. .10 20c 3/16 sq. .8 20c 3/8 sq. .6 20c 3/4 sq. .8 20c 3/8 sq. .2 20c 3/8 sq. .2 20c Sheets, 4 times 18" Double the above price for genuine aircraft SPRUCE 18" Balsa Planks 1/2x1/2 .2 for 8c 1x1 .1 for 8c 1x2 .1 for 9c 1x2 .1 for 16c 2x3 .1 for 22c 2x6 .1 for 48c 3x6 .1 for 72c Plastic Balsa 4 oz. 23c. 1 oz. 10c PROP. BLOCKS 1/2x1 .1c 2x2x1 .2c 2x2x1 .3c 3x3x1 .4c 3x3x2 .7c 3x3x3 .9c 5x5x2 .17c

- SKYWAY GAS MOTORS No Premiums or Packing Charges on Motors—P.P. 15c Ohlson "19" \$14.50 Ohlson "23" 16.50 Ohlson "60" 21.50 Forster \$17.75 Ball Bearing 19.50 New Forster "29," Class B 16.75 "O.K." Special 15.50 "O.K." Twin, for radio con. 40.00 Dennyrite \$17.85 Unit 17.50 Brown D 12.50 Brownie \$7.50 New Brown "B" Now 16.50 New Super Atom 15.50 Mighty Midget \$9.50 Gwin 12.00 Tiger Aero 16.50 New Super "B" 15.50 Syncro B-30 \$7.95 PC-2 Kit 4.95 Sky Chief 6.95 Perky 10.95 Big Allowance for Old Motors! CEMENT CLEAR DOPE THINNER Banana Oil 1 oz. 5c, 1/2 pt. 30c 2 oz. 9c, pint 50c 1/2 x 1/2 x 8 5c 1/2 x 1/4 x 10 2c 1/2 x 1/4 x 12 3c ea. 1 x 1 1/2 x 12 5c ea. 1 x 1 1/4 x 15 6c ea. PLYWOOD -3/32 1/16 1/8 1/4 1/2 c

- Trexler Wheels 1 1/4, 1 1/2, 1 3/4 1 3/8, 2, 2 1/2 2 1/4, 2 1/2, 2 3/4 Gas. Mod. 2 1/2 \$1 3-1.25-3 1/2-1.50 4 1/2-1.75 M & M WHEELS 1 1/4, 1 1/2, 1 3/4 1 3/8, 2, 2 1/2 Gas Mod. 2 1/2 90 NEW 2" \$1.00 3 1/4 1.50, 3 1/2 2.75 4 1/2 2.75, 6" 4.00 PROPELLERS Balsa Paulo Ritz Wina Gas 5" 4c-7c Mtd. 6" 5c-9c 8" 35c 7" 7c-10c 10" 35c 9" 8c-10c 11" 35c 10" 9c-22c 12" 35c 12" 10c-28c 13" 35c 14" 12c-40c 14" 35c 15" 10c-50c 15" X 15" 10c 16" 10c X 16" 35c 18" 25c X 18" 50c RITZ Gumwood 8", 9", 10", 11" 15c 12", 13", 14" 15c 15", 16" 20c 17", 18" 25c

- GAS MODEL ACCESSORIES Champion Spark Plugs 3/4 or 1/2 50c Condensers—Metal, 15c Smith 25c Plugs & Jacks, Set of 2-35c val. 25c Midget Trip Jacks 25c val. 2-15c Terminal Clips 5/8" 10c val. 4-5c Gas Funnel, Alum. strainer, 25c Spaghetto Tubing 1/16" 3 ft.—10c Toggle Switch 50c val. 25c "3 to 1" SAE 70 oil—1/2 pt.—25c 12" High Tension Leads—Best—14c Booster Leads—50c val.—14c Masking tape—1/2x36—instruc. card 5c Alligator Clips—5c Solderless 10c Xl'at Mainfold—Keep Ship Clean Nickel plated 50" Streamlined \$1.00 Spark Plug Wrenches—any size. 20c Neoprene Tubing 1 ft. 15c VOIT WHEELS 3 1/2 1.50, 4 1/2 1.75 Race Car Set 6.00 Ball Bearing 8.00 COILS Smith—3V \$2.50 Competitor 1.75 Superlite 1.75 Powerhouse 1.50 Aero-Coil 2.25 Brown Jr. 1.75 U. S. 1.00 Wing & Tail Lts. 5/16, 3c 9/16, 10c 11/16, 12c per set TIMERS Austin \$1.00 Dural 1.00 ALUM. LEAF 3 sheets 5c BONA FIDE DEALERS Write for WHOLESALE PRICE LIST

- RUBBER-POWERED ACCESSORIES Model Knife, Surgical Steel Blade 10c Model Pins 1/2 or 1" 100 for 5c Sheet Celluloid 5x7 3c, 4x1 17. 15c Ball Bearing Washer 10c value. 5c Sandpaper, 12 sheets 5x5. 5c Lilliput Lights—for display, 3 lamps, wired, instruc. sheet, per set 60c Insignia 36—American, French, English, German, Squadron, in colors, gummed, per sheet. 5c Washers, pinhole, 1/8, 1/4, 2 doz. 3c Prop Shafts, doz. sm. 6c, large 10c Ball Bear, 1/16 15c ea 1/8, 33c Nose Plugs for 5c 1/2—8c, 3/4—6c, 1" 6c. MUSIC WIRE .014 8 ft. .2c .020 .028 6 ft. 3c .034 .040 6 ft. .6c .049 . . . 6 ft. 8c 1/16" 3 ft. 5c 3/32" 3 ft. 5c 3/16" 3 ft. 5c .003 10c .010 15c ALUM. BRASS TUB'G TUB'G per ft. 1/16 . . . 7c. .9c .049 . . . 10c. 14c 3/16 . . . 14c 10c Sheet Alum—ft. 003 10c .010 15c

FREE POSTAGE ON ALL U. S. A. ORDERS.

with all purchases over \$1.00 your choice of: (1) Model Water Sprayer. (2) Model Builder's Knife. (3) Choice of 3-20" Model Plans—Gurtiss, Heathe, Boeing, Driggs, Bellanca. (4) Masking Tape. (5) 6 sheets AA Tissue. (7) Sandpaper 12 sheets. SHIPPING INSTRUCTIONS: Packing cost on all orders 10c. 36" or 5 ft. 20c. To packing cost add 15% postage for U.S. possessions, Canada, foreign countries when order is over \$1 and 15c if under \$1. 5 ft. packages to Canada shipped Express Collect.

SKYWAY MODEL AIRCRAFT SUPPLY CO., 426 SIXTH AVE., DEPT. F, BROOKLYN, N. Y.

anything, or the whole plot would come out. The Japs who escaped are herded up at the other end of the island, but we'll probably just leave them there. I'll have to find the Old Man—" he went on toward the ladder to the bridge. A few seconds later Knight saw a

brief flash of light from the door to the admiral's cabin. "There's His Nibs now," exclaimed Doyle. "I'll go tell him th' dopc." After a few minutes he came back, mumbling to himself. "Now what?" asked Knight. "The old barnacle," growled Doyle.

"Almost took th' hide off of me. Boy, can he cuss a blue streak!" "And what brought that on?" demanded Knight. "Search me." Doyle grinned. "All I did was tell him th' Marines had landed and had th' situation well in hand." THE END

IN THE SLIPSTREAM (Continued from page 30)

climb. But Al Williams argues there's not a plane in this country which can "hold a candle" to the Nazi M-109. Yet both the T'hawk and that 'Schmitt are commonly rated at 360 m.p.h. On February 3 Italy remarked that it had only lost 20 planes in the whole Greek scrap. But we say, "Oh, yeah?"

On Our Defense Front

No less than 20,000 aero mechanics are needed in order to have ground crews for our 50,000 planes in 1942. . . . Now Roscoe Turner is talking about an armada of 200,000 converted flivver planes for home defense. We still say that idea's screwy—even at the risk of Rosc sickin' that pet lion of his on us. . . . Our Army has recently organized balloon barrage units. Maybe you didn't know it, but Germany and Italy have also adopted similar defenses. . . . The Navy has relaxed a lot of its higher math requirements, but you still have to have the same college savvy. . . . One of the firms which helps make our bomb sights is being investigated, German

affiliation is suspected. . . . An air raid defense school for firemen has been opened in Long Island City. . . . Coast aero plants are hiring something like 2,800 workers a week. . . . California's Mojave desert will be the site of a new A-A practice range. . . . Bills have been introduced in the House for a \$500,000 glider-training program. . . . Police teletypes in nine eastern states are going to bolster that air raid warning net.

War Tip-Offs

Most deadly of the flyers battling the Nazis are the Poles, according to Texan Ira Sullivan, formerly with the RAF. "They fly like madmen when they see a German," says he. After what happened to Poland, can you blame 'em? . . . England has secretly trained flocks of chute troops. This fact came out after that recent bail-out attack on South Italy. . . . Swearing by the "shotgun" brand of defense against dive bombers, Britain has gone from the 8-weapon pompom (Chicago units) to 20- and 35-barreled m.g. units aboard its new battle-

wagons. On the other hand, the U.S. Navy still seems to be working on the precision-firing theory. . . . Churchill declared 50 Stukas were recently knocked off in single "show" at Malta. Poor protection by Italian fighters, they say.

This and That

Many skymen think private flying is doomed for the duration of the defense—unless more facilities are provided. . . . England has contacted for a number of military autogiros. . . . Plans are being considered to build the 400-m.p.h.-plus Hawker Tornado in this country. . . . If you're eligible to join the NPJA—National Parachute Jumpers' Association—contact Joe Crane, Roosevelt Field, L. I. This bail-outer outfit's humming with some 250 members. . . . We like that CAB air safety slogan—"If you want to be 'wreckless,' don't be reckless!" . . . Cross-country and instrument courses are the latest on the CPTP list.

More Bits About Flyers

It's still rumored that Major Wick, famed Nazi 56-victory Ace, is in a Canadian prison camp. . . . Michel Detroyat, Thompson Trophy winner of a few years back, is now kingpin

of the horse-cab business in Paris. *Major Seversky* can put out other things besides planes. He just published a tuneful aero march titled, "Over Land and Over Sea". . . . *Capt. Mario Visentini*, 17-plane Italian Ace, has been killed in Eritrea. His plane, weighted down with two rescued comrades, crashed into a mountain. . . . Most famed fighting exploit of *Baron von Werra*, captured Nazi Ace who escaped into America from Canada, is said to have been the quick downing of three Britishers over an English drome and then the destruction of another five ships on the ground.

Just Chatter

It seems that Kay Kyser doesn't know his aeronautics. T'other night he said something about an air pocket being caused by a vacuum. . . . Least important news of the month

is that American Airlines used 9,056,040 ft. of teletype paper last year. . . . The world's ski jump record is around 327 ft. But wait'll those new Russian ski parachute troops start leaping! . . . To Britons, an enemy plane that's an easy shot, is a "sitter." The word comes from hunting lingo where it means a sitting bird.

New Stuff

Japan is now said to be making aero oil from vegetable matter. . . . Hitler's "secret weapon of the month" is related to be an "absolutely silent running" Ju-88 which "due to transparent-plastic construction is invisible beyond 2,500 ft." . . . Lockheed's John Canaday envisions speeds of 1,000 m.p.h. through development of a means to break up the air resistance which clutters the lead-

ing edge of an airfoil. At that speed, you could leave New York at 9 a.m. and arrive on the West Coast at something or other after 8—that is, *before you left!* You can figure it out yourself by the time belts.

North of the Border

Most Americans joining the RCAF come from the southern part of the U.S. . . . Overseas exemption is no longer granted when you enlist with the flying Canucks. . . . Meanwhile, Canada gets the prize for strange crack-ups. Two training jobs locked together in midair the other day and their pilots brought 'em in pick-a-back style. And another chap smacked his ship through a 23,000-volt power line—to check his speed when his engine conked. Yet there wasn't a single flyer injured in the lot!

THE END

TRY THIS SOLID VULTEE MODEL

(Continued from page 54)

are added on. The inner lines on the landing gear leg supply the pattern for this flap. If a pedestal model is being made then the landing gear may be eliminated altogether.

ASSEMBLY AND FINISH

ASSEMBLE the model by setting the wing into the belly after it has been thoroughly smeared with cement. Insert small model making pins and push their heads deep into the balsa. Fill up the holes with cement. The stabilizer is mounted on

top of the body with the rudder directly behind. After these parts have dried, form the fillets by gluing thin strips of balsa or a mixture of cement and balsa sawdust. Careful sanding will bring out good results. The filleting around the wing should be worked out so that the body and wing seem to merge into a single unit.

The details such as the prop, radio wires, bombs, and machine gun barrels may be added on after the ship has received its first coat of paint.

The Turkish plane is painted in aluminum throughout. The rudder is red with the star and crescent in white. The wing insignia is a red square bordered in white. The top of the nose cowl is black as is a portion of its sides.

The color scheme on your ship must not necessarily follow the one outlined above. Camouflaging effect enhances appearance of the model.

The pedestal should be made of a hard wood base and a pointed prong. Once the model is mounted onto the prong it should be cemented permanently. To get a preservative finish apply a single coat of diluted clear banana oil over the completely painted job.

NEWS OF THE MODELERS

(Continued from page 56)

Scoring of Flights

INDOOR. Scoring time for indoor models shall be the longest of 3 official flights for powered models; the longest of 9 official flights for non-powered models. Flight duration shall be scored to the nearest tenth of a second.

OUTDOOR. Scoring time for all outdoor models except hand-launched gliders shall be the average elapsed time of 3 official flights. Scoring time for outdoor hand-launched gliders shall be the average elapsed time of the 3 longest of 9 official flights. In computing average elapsed duration time in seconds, the second numeral to the right of the decimal shall be dropped and the average elapsed duration time shall be scored to the nearest mathematical tenth.

Sanctioned Competition

SANCTIONED COMPETITION. The Academy of Model Aeronautics will sanction model aircraft competition which is conducted according to its official regulations.

CLASSIFICATION OF SANCTIONED COMPETITIONS. The Academy of Model Aeronautics classifies sanctioned contests and record trials as follows: Class A—"Closed competition," a contest open only to members of a single model air-

plane club, or affiliated model airplane organizations; Class AA—"Invitation" contest open to licensed model flyers with awards available to all who enter; Class AAA, state or regional championship contest which is large in size, draws 100 or more contestants and offers important awards; Class AAAA, national and international championship contest, which offers traditional trophies of the Academy of Model Aeronautics; and Record Trials, a contest conducted for the sole purpose of providing an opportunity and facilities for attempts to establish or surpass official model aircraft duration records, with no special awards offered to the winners.

OFFICIALS. All sanctioned contests and record trials shall be conducted by a contest director who has been appointed by the Academy of Model Aeronautics. To receive appointment, a contest director must be a leader-member of the Academy of Model Aeronautics. The contest director may name as many assistants as are necessary to insure a well-run competition. As many of these assistants as possible shall be leader-members of the Academy of Model Aeronautics.

OFFICIALS SHALL NOT COMPETE. The contest director and all officials asso-

ciated with a sanctioned contest shall not enter that contest. At no time shall any official of a sanctioned competition engage in any activities which interfere with the proper execution of his duties.

APPLICATION FOR SANCTION. Application for sanction of a model aircraft contest or record trials shall be made at least 30 days in advance of the competition by a contest director of the Academy of Model Aeronautics.

EQUIPMENT. Timing devices (stop watches) with graduations of not less than one-fifth of a second shall be used in sanctioned competition. Such scoring and recording aids as are necessary to insure a well-run competition shall be provided by the contest director or his assistants.

TAKE-OFF FACILITIES. Adequate take-off facilities shall be provided by the contest director or his assistants. Horizontal raised runways shall not be more than 6 inches off the ground or floor. For rise-off-water events the depth of the water shall not be less than one-inch indoors and not less than 6 inches outdoors; the surface area of the water shall be large enough to permit free take-off.

TERRAIN. The terrain for outdoor competition shall not vary as to difference of level and location more than standard practice for landing areas of airports.

RECORD OF COMPETITION. A complete report of each sanctioned contest or record trials shall be filed with the Contest

Board of the Academy of Model Aeronautics by the contest director within 7 days following the competition. The report shall include the names, ages, and addresses of all entrants and their individual flights in each category and class. Report(s) of record performance(s) shall be filed with the Contest Board of the Academy of Model Aeronautics by the contest director within 7 days following the competition. Failure to fulfill these requirements may result in revocation of contest director's appointment.

WHO MAY COMPETE. Only those who hold membership in a model airplane club affiliated with the Academy of Model Aeronautics shall be permitted to enter the events of a Class A competition. Only those possessing the gas model flyer's sporting license issued by the Academy of Model Aeronautics, or the special "Letter of Authority to Gas Model Flyers Under 14," shall be permitted to enter events for models powered by internal combustion engine(s) in Record Trials and Class AA, AAA, and AAAA contests. Only those possessing the gas model flyer's sporting license or the rubber model flyer's sporting license issued by the Academy of Model Aeronautics shall be permitted to enter events for non-powered models and models powered by other than internal combustion engine(s) in Record Trials and Class AA, AAA, and AAAA contests. The contest director of every sanctioned competition or his representative, shall examine the sporting license of each contestant to determine its validity and the contestant's eligibility to compete.

BUILDER OF MODEL. Each contestant shall assemble and cover all lifting surfaces and fuselages. The design may be obtained from any source. Only the builder may fly the model for record or in sanctioned competition. Models built from kits are acceptable. For all models other than those powered by internal combustion engines, the builder must build, carve, or complete the propeller(s).

NUMBER OF MODELS. Each contestant will be allowed a maximum of 3 models in each event, and he may use any or all to complete his flights. The 3 models used may be of different design; and if an event is announced as a general category without specific size classes, the 3 models used may be of different size classes.

IDENTIFICATION OF MODEL. Each model powered by internal combustion engine(s) shall have the sporting license number assigned to the builder by the Academy of Model Aeronautics permanently affixed to the upper side of the right-hand lifting surface. Each outdoor model shall have a registration certificate bearing the name and address of the builder and pertinent information concerning its size characteristics permanently affixed to the model.

CROSS-SECTION DRAWING OF CABIN. In cases of doubt, contestants shall present a full size drawing of the maximum cross-section of the cabin model; drawing shall be ruled into half-inch squares.

AGE CLASSIFICATION OF CONTESTANTS. Contestants under 16 years are classed as juniors; contestants 16 or more but under 21 years are classed as seniors; and contestants 21 years or more are classed as open flyers. Records are segregated as junior, senior or open, according to the age of the contestant when the record was established.

DISQUALIFICATION. Any contestant who breaks any rule of a contest, or conducts himself or herself contrary to the ordinary requirements of common

PHANTOM MOTORS

FOR PRICE ... PERFORMANCE DEPENDABILITY

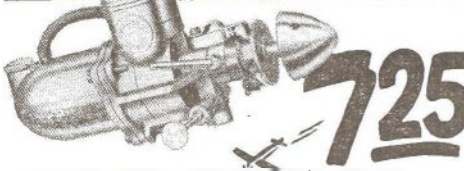

- BULLET & TORPEDO CLASS "B" ENGINE FEATURES**
- New special heavy duty type radial motor mounting (replaceable plus standard beam mounting).
 - Special float type gas gauge (Torpedo only).
 - Newly designed larger sturdier gas tank made from Magnesium alloy.
 - Gas tank can be mounted on either side of the fire wall.
 - All motors equipped with the new Smith "Fire-Cracker" Coil.
 - Torpedo produces almost 1/5 horsepower with weight of 4 3/4 oz.
 - Bullet produces almost 1/6 horsepower with weight of 4 3/4 oz.
 - Motors built to be used upright or inverted.
 - Your motor on its way 24 hours after order received.
 - Every motor power block tested in our factory and sold to you under a bonded factory guarantee.

WHERE can you get a model airplane motor which holds 3 world records; Altitude, Time in air, Air miles flown, for only \$7.25?

Is it any wonder that thousands of model fans have switched to Phantom. Phantom sells direct from the factory to you, cutting out all middleman profits. Phantom is built in the world's largest manufacturing plant for producing midget motors for model airplanes. Every motor is power tested before it leaves the factory, and is sold to you under a bonded factory guarantee. Don't delay! Clip the handy coupon below and we'll have your engine rocketing on its way to you in less than 24 hours after we receive your order.

PHANTOM MOTORS
800 East Gage Ave., Los Angeles, Calif.
Please RUSH the items checked below:

Money-order enclosed. Send C.O.D.

New improved 1941 Phantom "Bullet" complete with coil, tank and condenser - \$7.25

New Super Phantom "Torpedo" engine complete with coil, tank and condenser - \$10.95

Special 1 1/2 in. hardwood propeller - \$0.49

Miss Tiny Kit, Propeller and Phantom Built "Bullet" \$11.95
Add 3% if delivery point is in California.
Prices Slightly Higher in Foreign Countries

NAME.....
ADDRESS.....
CITY.....
STATE..... F:16

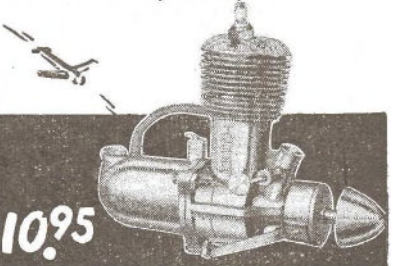

courtesy, may be disqualified upon recommendation of the officials. Models broken in landing are not disqualified.

EXCLUSION. A sentence of exclusion may be pronounced by the local contest committee against any entrant from any event or from all events in a contest or Record Trials, if the contestant is ineligible to take part in the events, or guilty of misbehavior or unfair practice. The local contest committee may order the removal of any entrant from the flying field or building who refuses to obey the order of a responsible official.

LOSS OF AWARD. Any competitor who may be excluded or suspended in any event shall thereby forfeit all right to award in that event.

PROTESTS. Protests will be considered only when presented in writing to the contest director within one hour after the close of the contest or record trials. The protestant must report in full the action or decision, the names of entrants and officials involved, and complete details.

APPEAL. Appeal may be made to the Contest Board of the Academy of Model Aeronautics on action taken on protest. Such appeals must be made in writing within a three-day period following the action of the local contest committee on the original protest.

EMERGENCY RULES. The contest director and the field judge may establish emergency rules if necessary, providing said rules are not in violation of official regulations of the Academy of Model Aeronautics.

Records

NATIONAL RECORDS. Perpetual American model aircraft duration records are homologated by the Contest Board of the Academy of Model Aeronautics. Per-

ONLY \$2 DOWN buys This New APOLLO with Sweep Hand!

Now, for the **FIRST TIME** a Sweep Hand to Measure **SECONDS** on a Wrist Watch that costs **ONLY \$5.95**



Again Swiss ingenuity, in a famous watch factory, has found a way to give you more for your money! Think of it—Men's Wrist Watch with an easy to read Sweep Hand to measure SECONDS—at the revolutionizing low price of \$5.95.

Men in aviation, men in the sports world, men at camp, men at sea, men in photography, men in the medical profession—all will find the Sweep second Hand of this new APOLLO a practical and useful feature! As a timepiece, dependable and accurate. Chromium plated. Untarnishable stainless steel back. Unbreakable crystal. Genuine leather strap.

ONLY \$2 DOWN ON 10-DAY TRIAL OFFER and Money Back Agreement!

Pay only \$2 down on delivery of your APOLLO. Wear it for 10 days on our Money Back Agreement. If not delighted, return in 10 days and your money will be refunded without question. Fill out and mail the coupon today!

ONLY \$1 ON DELIVERY SEND NO MONEY!

ARISTO
Lifetime Watches

ARISTO IMPORT COMPANY, Inc.
Dept. FA1, 630 Fifth Avenue, New York, N. Y.
Send me the APOLLO Men's Wrist Watch with Sweep second Hand, at price of \$5.95. I will pay postman \$2.00 on delivery and \$2.00 a month.

NAME AGE

ADDRESS

CITY STATE

EMPLOYED BY

ADDRESS

petual records may be established at any time and shall continue until exceeded or affected by changes in the official regulations.

ACCEPTANCE OF RECORDS. No record is official until it has been homologated by the Contest Board of the Academy of Model Aeronautics. Only duration records for flying model aircraft are officially recognized. All records to be eligible for recognition must be made in sanctioned competition under the regulations of the Academy of Model Aeronautics.

General

PROJECTED AREA. The projected area of a supporting or stabilizing surface is the area seen when looking directly down on the surface. Supporting surface area enclosed in a fuselage or stick shall

not be considered as wing area.

TUBE. A tube which is formed from sheet material shall not be considered as being built-up.

PUSHER-TRACTOR. The Academy of Model Aeronautics does not differentiate between pusher or tractor models for purposes of classification or record. However, such types are defined as follows: Pusher, a model airplane of the pusher type has its propeller(s) behind the supporting surface(s); tractor, a model airplane of the tractor type has its propeller(s) forward of the supporting surface(s); and tractor-pusher, a model airplane of the tractor-pusher type has its propeller(s) forward of, and propeller(s) behind the supporting surface(s).

VACUPLANE, ROTORPLANES. Vacuum planes and rotorplanes are not classified

by the Academy of Model Aeronautics.

LIGHTER-THAN-AIR MODEL AIRCRAFT. Lighter-than-air model aircraft are not classified by the Academy of Model Aeronautics.

EXHIBITION SCALE, FLYING SCALE, AND RADIO-CONTROLLED MODELS. Exhibition scale, flying scale and radio-controlled models are not classified for purposes of record by the Academy of Model Aeronautics. Such models are encouraged and suggested regulations are included in the Official Contest Manual of the Academy of Model Aeronautics.

INTERPRETATION OF REGULATIONS. The Contest Board of the Academy of Model Aeronautics shall be the final authority in the interpretation and execution of these model aircraft classifications and regulations.

THE END

SKY SABOTAGE

(Continued from page 27)

didn't have that many brains."

"That was nice, too. Wish we had a woodshed and a large paddle for a certain person."

"They were all civilians, and as poisonous looking a lot as one would want to see outside of a melodrama," the girl went on, ignoring the threat. "They were trying to figure out how they could put the bomber down somewhere near here—and then they came upon you. They recognized the plane as that of the Griffon's."

"Is that why they started firing at us?"

"I guess so. As good a reason as any."

"Was the other ship with you all the way from Florida?"

"No. That one joined us somewhere off Atlantic City, I think."

"Um, I'll bet old Lang was aboard that one," mused Keen.

"I wouldn't know. When they began firing, they shoved me into a tail compartment. And when you set us on fire I figured it was all up, but I got a parachute. . . ."

"Where from?"

"The rear gunner. He was wounded badly and opened the door. I saw he was done and had no trouble getting his chute. Then I tried to get out of a window."

"We saw all that. You sure had what fills out the waistline, Pebbles," Keen said with undisguised admiration. "That show you put on kept us there, but we didn't know we were waiting for you."

"I hacked my way out with some emergency tools," the girl explained.

Keen sat staring into the fire trying to figure it all out. This was big. Anyone who had the nerve to swipe a whole squadron of Air Corps bombers had a real organization and this was no ordinary clambake. The fact, too, that they had made some definite gesture toward putting Keen out of the play made it all the more interesting.

"Did you hear anything that would give us any idea as to where they

holed up?" he asked after deep consideration.

"The only thing that stands out in my mind now is that they all kept using an unusual exclamation. At least, that is what it sounded like to me. Every once in a while they would say: 'Great Wass!'"

"Great what?"

"No. Great Wass. I'm sure that's what they said, and I decided that it might be a German phrase. But why would they use the word 'great?' If they were Germans, they would use gross wouldn't they?"

"Great Wass! You know, that's familiar, in a way. That's a clever trick, too. Let's look it up."

Keen reached up for an encyclopedia from a nearby shelf and flipped the index pages. In a moment he placed his finger on a line and said: "Here it is. That wasn't an exclamation. It's the name of a small island off the coast of Maine near Jonesport and Pleasant Bay!"

KEEN and Miss Colony spent considerable time checking up all available details on this mysterious island. It was just another off-shore island of no particular importance, and upon general study did not appear to offer any particular reason why it should be selected as a hide-out for a squadron of missing bombers. However, as Keen had pointed out previously, strange things happen when the public has been engrossed in a general program of war preparations. A squadron of airplanes could drop down in almost any ordinary community and the general public would accept them as an indication that at last something was being done about national defense.

Barney came in to report that they could clear out at any time now. The Black Bullet was serviced and the Packard was ready for a getaway.

"Take it easy," Keen said without looking up. "We've got to figure out why these planes are at Great Wass. There must be a reason for it. They

apparently completed part of their plan in getting control of the ships once they left the West Coast. That could have been worked from several angles, of course."

"Well, doesn't Mr. Scott say there are to be some Eastern Seaboard war games staged shortly?" Pebbles asked.

Keen's eyes glinted like turquoise gems.

"Twelve Douglas bombers, if they were bombed-up—that is, if they were fully loaded—could do a lot of damage amid a heavy congestion of aircraft. A couple of bombers slipping over LaGuardia Field could wipe out a great deal of our commercial aviation. A couple more could clean out Mitchel Field. Two more. . . . But why go on with this? We ought to be doing something."

"Well, we could call up someone and have the Army Air Corps clean out this Great Wass place," suggested the girl.

"We could, but we're not even sure about that," Keen replied quietly. "Besides, we have old Lang to think about."

"Lang?" boomed the Mick.

"Sure. They have him as hostage. He was probably a prisoner aboard that second Douglas."

"And you mean to say," the girl asked, "you are going to take the long risk for Lang? Why, he'd turn you in the minute you'd snatched him out."

"But we can't leave him up there," persisted Keen. "They'll knock him off the minute things begin to hum."

"Perhaps they've already done that."

"No. They'll grill him to a turn first, and I must say there's nothing quite like a well-grilled G-man . . . with parsley."

"Here we go again!" mooned the Mick.

"Right! Here we go again. Get going, Barney. We're off to Great Wass . . . before it gets light."

"What about me?" demanded the girl.

"You stay here and hold the fort. You need to rest and keep warm. We'll need someone at this end, anyway, to keep us in touch with what old Scott will have to say. If he asks

where you are, you tell him—well, tell him anything. Tell him we went down to New York to look for Lang in a couple of gin mills. Tell him anything."

Keen was flipping a sheaf of charts by this time, selecting one that would give him the best detail of the island and the most accurate soundings for his landing.

There was a general scurrying around for flying kit, boots, and kapok jackets. Barbara Colony went upstairs to get a quilt. She planned to settle down on the settee in front of the fire and await developments.

"Take no chances on anyone," warned Keen. "If they come in any door, except the one from below, take a shot at them and ask questions afterward. Take care of yourself, kitten."

He darted to another room and got a very disreputable get-up to wear under his black coverall. He selected heavy seamen's boots, coarse denim trousers, a sweater and a woolen cap that could be pulled down over his ears. He also took a brace of automatics that were stuffed away somewhere in his jeans. He came back, waved to the girl, and disappeared down the stairs again.

In five minutes the Black Bullet was again emerging from her subterranean hangar and crawling stealthily across the shadowy lawn.

"We sure are sticking our necks out this time," the Mick grumbled.

"You can stay behind if you like," suggested Keen. "As a matter of fact, I'd much rather pull this show alone."

"So I'm in the way, eh?" stormed O'Dare.

"Not that, particularly; but I don't want to be hampered with a scared passenger."

"Passenger? Passenger, is it?" the Mick exploded. "You think you can talk me out of this trip with a line like that?"

"I'm afraid you'll be in the way," taunted Keen, guiding the Black Bullet down into the water.

"Ye can call me a scared passenger if ye loike, but I'm going just the same!"

"I was afraid you would," said Keen, satisfied. "Now shut up and let me think while you keep your eye open for trouble."

THE BLACK BULLET zoomed away into the night under silenced motors and cleared the area swept by the blade from Montauk Light. They climbed to 5,000 feet and then set a course for the northeast, watching for the lights of Cape Cod. It was cold in spite of the comfort and convenience of the cabin, and Keen had plenty of time to plan his rescue.

He realized that he might be off on a fool's errand, and that the girl's suggestion about Great Wass might have been conjured under grim stress. She could have made a mistake, and yet Keen was so sure she had been right that he found himself planning far ahead. He studied the

chart carefully and decided to circle the place widely and come in from the north. He figured they would take almost two hours since the distance was close to 500 miles.

The island itself was typical of the Maine coast. It might be between four and five miles in length and less than a mile in width. It jutted out into the sea, lonesome and gaunt, and even the most elaborate map carried no details of any village or habitation. Possibly a few lobster fishermen, clam diggers, and hardy unfortunates who grubbed a bare living out of the stingy barrenness eked out an existence there.

How this gang could land, hide, and service a squadron of B-18 bombers there was more than Keen could figure. Still, they had swiped the bombers, and if they could do that, it was obvious that they could take care of them. The thing was bigger than anything Keen had ever tackled before—and he realized as the miles were peeled off that he had really taken on a job.

They cut across Vineyard Sound through Buzzard's Bay and over the gleaming gash of the Cape Cod Canal. Then Keen swung due north, keeping clear of the coast outside Massachusetts Bay, and then turned inland again once he had passed Gloucester. From that point on he had to concentrate on his navigation and he aroused the Mick once more to be on the lookout for opposition from the air.

They were racing the dawn now, and Keen had to think and act fast. There could be no making mistakes now. They had to hit Great Wass on the nose and lose no time. A daylight landing was out of the question.

At last, the long sliver of land appeared on the horizon and Keen made a calculation as to its exact position. He checked with the surrounding area and picked out Head Island and the jutting promontory that was South Addison. He cut wide of Head Island and then cut the motors to their slowest idling speeds.

"Okeydoke! Here's where we get it quick—or else," Keen said, turning to O'Dare. "Rub those dice of yours, will you?"

The Mick did not answer. He was too busy keeping a silent watch aft.

The Black Bullet slipped down out of the night and slithered toward the ghostly gleam that rimmed the edge of Great Wass island. There was a certain amount of light from the froth of the surf and the steely glint of the sand. The island itself seemed deserted, but there was a sullen gleam about it that was none too reassuring.

The few minutes devoted to a safe and as quiet as possible glide were full of apprehension. Keen headed the black craft for a point that promised a haven on either side. He brought her down beautifully and skipped the rollers with hardly a sound. The Allison engines were well muffled and the Black Bullet made no particular sound as she was brought around and

The Realist Thing Yet in War Models

—typical Cleveland authentic 3/4" scale— That's Why!

Every One a Beauty in Looks & Flights

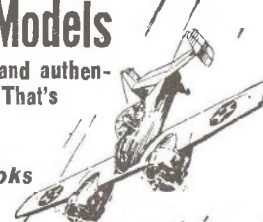

SKYROCKET

Big 3 1/2" scale job of America's new twin motor 450 m.p.h. "Terror of the Skies." Fast flyer with both motors pulling. Yellow and blue. Complete Kit SF-75, only **\$3.00**

SPITFIRE

Beautiful 2 7/8" scale model of England's popular interceptor fighter. Large wing area assures excellent flying. All silver (with suggestions for green and brown camouflage). Complete Kit SF-73, only **\$2.50**

The Pride of the R.A.F.

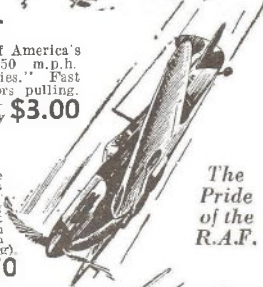

AIRACOBRA

2 5/8" scale model of America's amazing "cannon-plane" standard pursuit interceptor. High speed flyer. All silver. Complete Kit SF-76, only **\$2.50**



MESSERSCHMITT Me-109

Fast flying 2 1/2" scale model of Germany's "shark" fighter. Black and white. Complete Kit SF-74, only **\$2.50**



You're in the money with the 80" **PLAYBOY Sr. Gas Model**

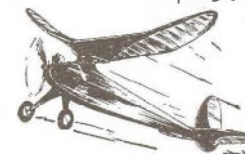

This is one of the most astonishing gas model performers yet developed. In meet after meet it has broken records, carried off prizes and honors. Be sure to feature it. Huge 80" span. Beautiful flights. The talk of the model world. Kit GP-5017 (complete except power unit) only **\$3.95**

Other PLAYBOY Gas Models

46" Playboy Jr. Kit GP-5006 (complete except power unit) **\$2.50**
33" Baby Playboy. Kit GP-5008 (complete except power unit) **\$1.00**

And these are the Realist Yet in Big Gas Models—



STINSON RELIANT

Big 80" span. Most popular in U.S. for radio control work. Complete Kit GP-66 (except power unit) only **\$8.50**



REARWIN SPEEDSTER

Called most beautiful scale job on the market. Complete Kit GP-69 (except power unit) only **\$7.50**

Super Values in Gliders!



BIG **CLEVELAND CONDOR** Soaring Glider. Span **\$1.00**
84". Class D or E. Complete Kit E-5019

CLEVELAND EAGLE Soaring Glider, Span **50c**
48". Class C. Complete Kit E-5018

ORDERING INSTRUCTIONS: If your dealer can't supply you, order direct by check or Money Order—cash at own risk. Shipments outside U.S. add 10% (Remit in U.S. funds). For P. P. Special Delivery in U.S. add 25c. (Ohio resident: add 3% sales tax).

Send 5c for New Airplane Catalog of entire Cleveland line—"America's FIRST LINE of Flying Models"—scale, gas glider, indoor, outdoor, etc., from 25c up. Also Race Car Catalog, 5c; Ship Catalog, 5c; Railroad Catalog, 5c. Send for the ones you want.

CLEVELAND MODEL & SUPPLY CO., INC.

"America's FIRST LINE of Models"
450RA42 Lorain Ave., Cleveland, Ohio, U.S.A.

CHAPTER III

THE OPENING NIGHT

headed for the cove that offered the deepest shelter.

"Keep your eye peeled and shoot the minute you see anything move," said Keen over his shoulder.

The Mick grunted a reply and drew his hatch-cover back as the amphibian rolled up the sands. There was plenty of room and the beach appeared to be clear.

"Get out and go up toward those rocks and see what shelter there is there," ordered Keen.

The Mick cleared quickly and was soon back with: "It's perfect, Boss. Bring her up about twenty yards and we'll turn her around and back into a spot here. We can daub her up with seaweed, and she'll look swell from the air."

They went to work, and in about fifteen minutes the Black Bullet had been well hidden and camouflaged. Both Keen and Barney then stripped off their flying gear and assumed the drab but warm appearance of a couple of native fishermen. With a last glance at their plane, they clambered up the rocks to get a better view of the area surrounding them and to get their general bearings. They crawled through some scrub pine and over the jagged facings of rock and lay flat. Ahead of them through the fringe of the low stubble they could see that the island offered nothing in the way of buildings within their scope of vision.

"We picked a bloomer, Boss," the Mick muttered as they lay there. "There ain't even a clam-digger's shack on this island."

"Well, we gave it a whirl. Still, I'd like to see it in the daytime."

"Guess we will. We won't be able to get away now and go back to Long Island in the darkness."

Keen lay there and then suddenly grew tense. There was nothing but scraggy trees and rocks around them, but from somewhere came a strange electric thrill of impending danger.

"Listen! Listen carefully," Keen said quietly.

They lay there listening, but somehow could not identify the sound both had caught by now. It seemed to be all around them, and yet they could see nothing.

"I get it, Boss," the Mick said quickly. "Listen—and cover your eyes."

Keen put his face down into his arm and listened again. The sound was below them now—somewhere in the ground. A dull rumbling of machinery, movement of heavy bodies, like the initial rumblings of an earthquake.

"It's in the ground, somewhere."

"That's what I think, Boss. Like being over a coal mine with the engines going."

"That's just exactly what is it, Barney," Keen suggested. "We've caught it. There's a hidden hangar somewhere on this island. A cave where they have engines of some kind working! Listen, I can hear it plainly now."

"COME ON," Keen said suddenly.

"We're going to find out what this is all about. They got up, cut across the ground, and made their way back to the beach. Then they started along the rocky wall that rose up from the sand.

"If anyone stops us, we're a couple of lobster fishermen out of Mill-bridge. We left our boat about a mile further back up the beach. Get it?"

"I do, and I hope these guys believe us," the Mick moaned.

"I don't care whether they do or not. We're going to find out about those bombers."

They mooched along the beach, keeping a weather eye open as the faint tinges of dawn began to streak up from the east. They loped along with shuffling gaits and assumed all the outward visible signs of boatmen who were simply beachcombing. They carried on in this manner for a mile or so and gradually the light improved and they could see decayed evidence of old fishing huts, net drying shacks, beached derelicts and the usual flotsam and jetsam of a deserted island.

They rounded another point to the east and stopped suddenly. The beach around the point was open and half-moon in shape. It was wide and the stretch of silver sand seemed almost artificial. The gaunt walls of the rocks backing up this half-moon seemed artificial with their strange grayish tinge.

"We're coming on to something, Boss," O'Dare whispered.

"I don't like it either. It seems too real, too detailed to be real. But keep on along this point of the beach. We'll stay away from that rock wall."

They were cutting across the widest portion of the beach and only glancing at the rocky wall at intervals. They stopped once and stood with their feet firmly planted in the sand, staring out to sea but listening intently and trying to draw sounds out of the ground.

"They've got to have ventilation, if they're underground there. Let's hurry along and then cut inland again."

Twenty minutes later they were working their way through scrub gorse rocks and wind-stunted trees to a natural amphetheater of sand and rock. They huddled amid the shambles of tree trunks and broken rock shelving, listening.

Keen caught it first. The faint smell of hot oil and the pungent odor of gasoline. "Come on. I've got it," he said suddenly, leading the way toward a heap of rocks that were fringed with small, stubby plants.

They crawled slowly toward the pile and lay flat. The effect was uncanny at first, but it was just what Keen had expected.

There amid the rocks was sheltered a gray painted tube suitably covered with a conical weather guard. It was the outlet for a combination of smells

and sounds. They crawled up closer and listened.

At first the sounds were indistinguishable, but gradually they were able to sort out the sentences and sift them from the metallic jumble and the intermittent roar of engines. In fifteen minutes they had all they wanted to know and rolled over to consider the situation.

"Well," a voice behind them said sullenly, "would you two G-guys like it now or should I take you both below and let the wolves rip you apart?"

THEY TURNED to see a particularly offensive-looking, lug-eared man holding a Springfield rifle on them. He held it with an air of one who knew what it was all about.

"I've been watching you two guys since you came up from the beach," he went on, glancing down at them with a sneer that would have curdled battery acid. He gloried in his position for he was certain he had made quite a capture. "You want to act gay now and get a couple of .30's in your bellies, or would you like to go below and see the works before they put you through the meat chopper?"

"Cheerful prospect," said Keen, "but it might be worth the experience."

"Couple of nosey guys, ain't you?" the sentry gent cracked. "I wonder how you got here? Well, you'll get the low-down below and then it won't be any use to you."

"I'd like to bust you one in the snoot," the Mick broke in. He had caught a signal from Keen and was putting on his act. "I bet you I could put you away in one round wit one arm tied behind me back."

"I'd like to give you the chance, lug. But your pal might not play the part of a ringsider. Well, what is it? You going down and let the boys look you over, or are you going to get rough and make me plug you here?"

"Let's go, Pulski," said Keen, using the Mick's undercover name. "We'll go below, as he puts it, and scare hell out of them."

"Don't gimme that line," said the sentry. "Come on!"

The Mick got to his hands and knees and covered Keen as he arose. Then he caught the wink from his boss, bent over carefully, knocked the sand from his knees and brushed his hands together. He made a quick move and the confused sentry had no time to make a move.

Keen hurriedly picked up a large smooth rock with his right hand. As Barney turned and twisted out of line, he let fly and smacked the sentry lug full between the eyes. The Mick twisted like something made of whalebone again and caught the man before he could fall. He snatched the rifle clear and lowered the gangster to the ground.

They worked fast, binding up the wound with strips from the man's shirt, shackling his legs with his belt, and then tying his hands behind him with his necktie and rifle-sling. The stone had cut a fairly deep gash, but

it was none too serious except that it had swelled, closing both eyes and adding an extra pugnacious contour to his nose.

"Nice pitching," said Barney when they had completed the job. "What now?"

"Make sure he's secure and then we'll tuck him away somewhere in the scrub until we need him. Then we'll get off this place and try to find a telephone."

"You gonner call out the Army?"

"No. Pebbles. Give her a message and let her be the Griffon and tip off John Scott later on. They'll probably attack New York tonight and try to clean up every military field on the east coast."

"What do I do that's screwy?" asked the Mick with a grimace of resignation.

"You stay here and play sentry. You can have the rifle and this guy's ammunition. You just wander about and look wise as long as you possibly can. I'm getting back to the mainland somehow."

"I figured I'd be stuck for something," the Mick growled.

"What about me? I may have to swim for it."

HOW BARNEY managed to stick out the long day, crawling from cover to cover and still maintain guard over the bound and gagged sentry, he never quite knew. Keen had disappeared over a ridge hours before and there was nothing to do but sit there and await developments.

At intervals he crawled back to the disguised breather pipe and listened intently. As the hours crawled by he was able to collect enough information in snatches to realize that something big and something beautiful was about to burst from below.

"Keen had better get back here fast and be ready for anything," the Mick grumbled to himself as the first hint of evening began to creep across the sky. "These guys are going to clear out the minute they can get a break, and it sounds like bad business."

Another sentry came over the rise of a sand dune and peered about. Barney stayed low and watched the captive to make sure he would in no way make an outcry. It was obvious that the man had been missed and they were attempting to solve the mystery of his disappearance.

"Come on, Keen," the Mick breathed to himself. "Come on, Boss! We ain't got long to gamble."

The second sentry stood not twenty yards away, trying to figure out some footsteps. Suddenly he twisted and crouched. He backed away and slid into position behind a pile of boulders fringed with gorse.

O'Dare became electrified and started across the gray sands. He sensed what was happening and moved quietly in a half circle as the sentry drew back the bolt of his Springfield. Barney ran half a dozen steps and then froze as the man peered about. There was a minute or

two of strained silence and then the guy turned to look over the pile of rocks. The Mick moved like a wraith and trapped the sentry as he began to draw up his rifle. A short, cruel hook exploded under the man's ear and he flopped forward. The Mick grabbed him by the shoulder and brought up a fist with the speed of a projectile, and the sentry lost all interest in the rest of the proceedings. He simply flopped back and Barney had another mug on his hands to tie up.

"At last! I thought you'd never get back! Where you bin?" the Mick asked as Keen drew in sight.

"Swiping boats, crawling up cliffs, mooching rides, and hopping freights all over the state of Maine, trying to find a telephone that works. What's in the freezer?"

"They're getting away the minute it gets dark enough. I heard that through the pipe. There must be a real dump below this place."

"Know what it is?" asked Keen as they finished up the sentry's fetters. "It was once an old feldspar mine and it ran in a queer series of layers. I found out about it in some old papers in a library on the mainland."

"But think of the size of the place!" the Mick ejaculated.

"Right! When they exhausted the feldspar they left this big cave and the family that owned the island a number of years ago was crazy enough to try to wall it up and try to sell the island to the Government as a submarine base. In those days the Government laughed it off, and eventually the whole thing was forgotten. Anyway, it seems now that someone remembered this place and decided it was just what they wanted."

"What color is feldspar?" asked the Mick.

"Whitish yellow. It's perfect for an underground hangar idea. Reflects light beautifully and is no trouble at all to illuminate. This is a real threat, as long as these guys hold the fort."

"They're not holding it after tonight. They're getting out!"

"Hear any details?"

"They talk like an income tax report. All figures and letters. No names or places mentioned."

"Well, we've got to find out. It's getting dark enough to take a chance now. Put that rifle over your shoulder. We're sentries—for keeps!"

They took the cartridge belt from the second man, and Keen buckled it on at a jaunty angle about his hips and nodded to O'Dare. Then they set out through the dull leaden light of the dying day with the Mick in the lead. He had watched carefully all afternoon and had discovered the headwall track over which the sentries had climbed to get to the high reaches of the island.

The path led amid blocky sentinels of gaunt rock and then began its way down the face of the cliff. Ahead and below they could see the silver of the sand and the froth of the whitecaps. Beyond that, nothing moved.



LATEST NEWS
in the World of
PHOTOGRAPHY
MUSIC • SPORTS

Mail the Coupon for NEXT 5 ISSUES

More than 60 beautiful pictures in rotogravure—up-to-the-moment news of PHOTOGRAPHY—Just off the press! Cast a critical eye over the many new camera "shots" reproduced from cover to cover of Rabsons Magazine. Read, too, about the newest gadgets in the sphere of indoor and outdoor sports and the latest reviews of recorded music and radio.

FEATURES BY EXPERTS! Each subject is "covered" by an outstanding authority! Be right in step with your favorite hobby—read every issue of Rabsons! Additional features: pages of photo-news from Hollywood and Broadway!

Introductory Offer
5 BIG ISSUES—for ONLY 25c

Let us send you FIVE BIG ISSUES of Rabsons for only 25c—less than the cost of producing and mailing this fascinating Magazine! Simply fill out the coupon, enclose a quarter (coin or stamps) and mail today.

MAIL COUPON TODAY



PHOTOGRAPHY • SPORTS • RADIO • RECORDS

RABSONS, Dept. 365M
111 West 52 Street,
New York City

I enclose 25c—please mail me FIVE issues of Rabsons Magazine. Send at once the current issue—just off the press! No further obligations on my part.

NAME

ADDRESS

CITY STATE

BUILD WORLD FAMOUS WARSHIPS - RACE CARS AIRPLANES!

Complete Kits . . . No Extras to Buy!
See Your Dealer!

AIRCRAFT COMPANY, CHICAGO

"G" LINE FLYING
Sensational - New - Thrilling



THE BABY SHARK
Newest "G" Line Sensation
Designed for all Class A & B Motors, the BABY SHARK flies at tremendous speeds of from 50 to 75 M.P.H. Amazingly Stable in Flight.

COMPLETE KIT,
Only \$1.98. Postage 25c
Illustrated Descriptive Folders 5c

VICTOR STANZEL & CO.
Schulenburg, Dept. F, Texas

LEADER'S 3/4" SUPER DETAILED SOLID SCALE MODEL

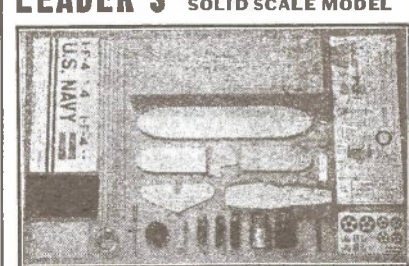

Actual photo of BOEING F4B4 kit

BOEING F4B4
Kit contains all balsa parts cut to outlined shape, aluminum drive pins, five bottles of liquid, wheels, celluloid motor, metal propeller, sandpaper, more than enough balsa for struts, wire, pins, insulators, and clear full size plans.

COMPLETE KIT 50c
add 10c for postage

TAYLORCRAFT 50c
COMPLETE KIT 50c
add 10c for postage

Both kits for only \$1.00 postpaid

WE CARRY A COMPLETE LINE OF RUBBER AND GAS MODEL AIRPLANE, BOATS, and RACECARS KITS and SUPPLIES. SEND 5c FOR PRICE LIST
Dealers Send for Discount Use Letterhead

LEADER MODEL AIRPLANE CO.
5130 So. Damen Ave. Dept. F-5 Chicago, Ill.

They drew their rifles and then assumed an air of bored inattention. They kicked loose rocks, gradually reached the level of the beach, and then slung their rifles from the shoulder sling and moved boldly forward to the bend in the cliff beyond which they knew was the secret entrance to the feldspar cave.

Keen took the lead at this point and used his eyes carefully to detect the beaten track in the sand and to find a mark that would indicate just where an entrance could be effected. The frontal portion of the cave looked like a series of gray granite buttresses of some ancient temple. They glistened with specks of mica and flecked sand. Keen moved up carefully and ran his hands over a portion, rapped at it with his knuckles. It was hollow and sounded like tin bent over a heavy wooden framework.

"The Chamber of Horrors, Coney Island," he started to say, but before

he could finish, a section of the wall opened on well-greased hinges.

"Wadderyer want?" came the demand. It was an impressive voice, one with heavy slugs in it, and both Keen and the Mick winced for fear they'd been trapped.

"It's okay! We're just looking for our relief," said Keen in a dull tone.

"Well, don't yer know yer own entrance?"

"Sure! But we came down the other side this time," Keen said, not knowing why.

"You guys better keep awake, or you'll wind up missing like them other mugs."

Keen grumbled something back over his shoulder and hurried along.

"You will tap walls," O'Dare said. "Anyone can tell its tin without doing that."

Suddenly there was an ominous rumble all about them. It seemed to come mainly from somewhere beneath their feet. Then as they stood

still in uncertainty, the walls near them grumbled and set up a low metallic drumming. Before they could move farther, a slim gash opened up, creaking and rumbling as the gash became wider and wider.

CHAPTER IV

DRURY LANG—HERO!

THE WALL GASH became wider and they saw the well-greased track about a foot inside the base of the false buttress. It was set on a raised curve of concrete. There was a jutting apron of false metal bottom to the door which trickled through the sand and gave the impression that the wall was real and actually rose out of the beach. But as the doors slid back, the sand trickled away from the slanted skirting. Keen and O'Dare were silhouetted in the darkness against the dull gleam that came from the hidden hangar.

"Keep waiting," ordered Keen out of one side of his mouth. "Play up to them!"

They followed the gaunt face of the big door as it rumbled along. Out of the corners of their eyes they could see a number of indistinct figures grouped about the bombers which had been drawn in with their wings dovetailing in true military precision.

A motor or two opened up with a bellow and the figures moved as if by some mechanical means connected with the starting of the Douglas' engines.

"We've got to stop these guys from getting out!" warned Keen. "Get a prop at a time!"

They moved quickly across the mouth of the hangar and hurried to a point where the great doors provided slight cover. Barney kneeled and Keen straddled him in a space left by an inner door section. They selected their targets and fired.

The reports seemed muffled under the bellow of opening motors, but the effect was startling. One engine spat sparks and then hurled a steel propeller blade hard against the solid rock floor of the hangar. It bounced with a terrific clang amid a group of men who scattered in all directions.

Barney's gun fired again and another whirling prop screamed and began to wail in uneven jerks. Keen squeezed his trigger and the shell of a controllable pitch gear-box blew up, throwing chunks of metal in all directions.

"That's all," Keen said quickly. "Come on!"

They realized that they had damaged the front machines at least and that they would have to be moved out before the others could get away. There were shouts and shots somewhere behind them and they stopped suddenly, flattened against the wall, and a thundering herd of mechanics and airmen poured past in the darkness. They had left their rifles stacked against the wall, quietly walked back, and slipped inside the gloom behind the hangar doors.

Aero Book Reviews

Any volume described in this department may be obtained, at the price quoted, direct from the publisher named and at the address given. When writing for a book kindly mention that you saw it reviewed in FLYING ACES.

War Over France

Squadrons Up! by Noel Monks, Whittlesey House, McGraw-Hill Book Co., 330 West 42nd St., New York City, \$2.50.

One of the many things we've found wrong with this current war is that there are not enough books being written about the air aspect. This book, however, does much to fill that much-needed hole, and your reviewer believes that *Squadrons Up!* will be literally eaten up by the general air public.

The book deals entirely with the Advanced Air Striking Force—that gallant group of Royal Air Force men that was sent to France to combat Hitler's *Luftwaffe*. Human interest abounds, telling of the hardships, the victories, and the defeats those boys went through. How they prayed in vain for many months to get a crack at the Germans—only to have the Nazis remain at an altitude the RAF Hurricanes couldn't reach. And how, at last, they piled up an enviable record of confirmed victories, losing only a scant few of their own men in the bargain.

Arthur Noel Monks was a war correspondent for the London *Daily Mail* during those hectic days in France and he got to know very well such men as Cobber Kain and Squadron Leader Knox. And this book, we might mention, gives the only story we've seen concerning Cobber Kain's untimely death—the true story, that is.

(Also see pages 63 and 78 for other reviews)

Written in a simple, down-to-earth style, *Squadrons Up!* is one of the best air-war books we've seen and the only one on this present Nazi War. Beg, borrow, or steal, if you must—but don't miss this thrilling volume.

Ground Instruction

Aeronautics. General Editor, Don Ryan Mockler, National Aeronautics Council, 37 West 47 St., New York City, 25c.

Have you ever noticed that advertisement we frequently have on page 3 in FLYING ACES? It is headed "Now! Amazing Opportunities to Get Started in Aviation!" Well, this is Issue Three of that course.

Various chapters are handled by Swanee Taylor, Prof. Jean Piccard, Prof. John E. Younger, and Col. Roger Q. Williams. These well-known aviation personalities are among the best in the field and they put over in written form very well the knowledge and experience they have assimilated in their years and years in aviation.

Your reviewer has not seen other volumes in this series, but he can definitely say that Issue 3 is more than worth the purchase price. The book contains 192 pages and explains the following topics: Ground Instruction; Principles of Flights and Instruments; Materials, Certification, and Inspection; and Civil Aviation Careers. That, we believe, is all-inclusive—dealing with everything from the time before you step into an airplane to the moment you are ready to apply for a job.

If you haven't already enrolled for booklets in this National Aeronautics series, we suggest that you do so immediately. And if you're not pleased, it definitely won't be because of the material contained.

"Now we're in for it," the Mick mooned. "If we're caught they'll ram us through a prop and show us what it's like."

"Keep moving! We've got to find. Lang."

"He's probably cooked by now!"

The hangar was a bedlam now. It was a prime example of what can happen to a great organization which suddenly faces the unexpected. The place was in chaos. They were uncertain just what had happened. The sudden, unexplained breaking up of three or four of their propellers left them frantic with fear.

Keen sensed all this and he made the most of it. As soon as he caught anyone looking at them he began to gesticulate and bellow. All the time they were running around the edge of the great cavern, peering into doors and over low barriers.

They passed shops, fuel stores, and spaces where bombs were stacked. They clambered past piled engine crates and along heavy work-benches. Then they came to sections that had real doors and they listened outside each in turn until at last Keen stopped, nodded to Barney.

They drew out masks and put them to their faces and unholstered their automatics. Their appearance now was such that even Miss Colony would never have recognized them.

"Come closer!" whispered Keen.

They both listened outside the third door and heard somebody say: "You got exactly thirty seconds to spill it."

"I tell you, I don't know. How can I know?"

That was Drury-Lang, as sure as they were standing there.

"We've lost two sentries," the booming voice went on, "and now someone has fired shots into the..."

But that was as far as he got. He didn't see the door behind him open, and had just started to ram his big black Luger against Lang's forehead. Just then, a bullet from Keen's gun bored into his back and made him relax and slide to the floor. Three other men who had stood by were frozen with the realization that they were cold meat for the two masked invaders.

LANG WAS STIFF with fear. Keen kicked the big man's Luger over toward his feet and made a suggestive flick with the muzzle of his own automatic. Lang picked up the Luger and moved like a robot while the Mick went around bopping guys on the thatch with the heavy end of his weapon. In less than forty seconds they had cleaned up the place and were shoving the perplexed Lang out into the maze of the hangar.

"Where did you guys come from?" he asked over his shoulder.

Keen didn't answer. He simply shoved Lang on, skirting the bombers. They moved up close to a Douglas which had its cabin door open. "In there!" ordered Keen, disguising his voice. "Hide in the navigation compartment. Stay there until someone comes for you. And if they get away

with this one, stay aboard until they are clear and then force them to fly you to Mitchel Field. That's your job. I've done mine."

"Who are you?" husked Lang.

"Your old friend," whispered Keen.

"Not—not the Griffon?" gasped Lang.

"Think it over," said Keen, shoving Lang into the cabin and noting the markings and squadron numbers. "Stay with this tub to the end."

"Hell!" gasped the amazed Lang. "The Griffon!"

Keen and O'Dare eased into the shadows again, creeping like wraiths under wing-tips, around tail assemblies, and under the big bellies of Douglas bombers. The disabled bombers had been moved out into the open and two others were ready for the take-off.

"Those two now," said Keen. "You take the one with the red stripe and I'll get the far one. Then beat it for the Bullet!"

They slipped off their masks and sought something with which to accomplish their aim. Nearby was a stack of five-gallon oil containers. They selected four of these and picked them up, and with all the boredom of two underpaid mechanics they started out boldly for the sand area in front of the doors.

Keen gave Barney a glance as they parted. The Mick walked around the first bomber and put the cans down as if to give his hands a rest. Then he picked up one, hefted it carefully, and calmly hurled it with great force at the whirling prop of the starboard engine. There was a tremendous scream of outraged metal, the bong of a battered oil drum, and the blinding storm of oil as the Mick grabbed the other and repeated the business before those in charge of the ship realized what had happened.

Two more props were out of order and there was an ear-thumping jangle of metal and the flash of dull brown oil across the stretch of sand, and the Mick knew his boss had also scored.

They moved now with the speed of insane devils. A flutter of machine gun fire pecked up the sand all around them. Hoarse voices challenged and threatened them as they raced for safety. A group of wide-armed men came out of the darkness ahead of them, but both Keen and Barney had their automatics out and they charged in, firing on the run, and blasted a runway through the lot. More shots over their heads and past their ears and then the roar of more engines.

Eventually, they were in the clear and speeding with the easy strides of conditioned distance runners across the gorse and sand of the island. They drew up and sought the path down the face of the rocks and made their way to where they had left the Black Bullet. They halted a moment, silhouetted against the bleak night sky, and listened.

The only sound that came was that from high above and from the open stretch of beach well behind them



MODEL MAKERS! TRY PLASTIC WOOD

For modeling airplanes, ships, coaches, trophies, puppets—PLASTIC WOOD is an ideal medium. It handles like putty; hardens into wood. Moulds readily—and when dry can be carved to secure any details desired. In cans or tubes at paint. hdwe., 10¢ stores.



PLASTIC WOOD



This "fixer" quickly and permanently joins and repairs china, glass, wood, celluloid. Excellent for use in model airplane making.

TRANSPARENT OR METAL COLOR

GAS MOTOR \$4.95

Complete kit to build new Synco Class "B" gas motor, all parts included. Including coil and condenser Complete\$5.95 P.P.



Knocked down with Plan and Instructions

- Motor can be assembled and ready to run in 30 minutes.
- LAPPE D PISTON & CYLINDER
- COUNTER BALANCED CRANK-SHAFT Fully Machined
- COMMUTATOR TYPE TIMER (No points to adjust)
- Entire motor made of Aluminum alloy for lightness and strength

* Champion Spark Plug. All for \$4.95. This motor is designed thruout to give the maximum performance. Test motor was run 200 hours continuously without changing anything but the spark plug. Be the first to have this record breaker. This is the best buy of the year. Send for it now. IMMEDIATE DELIVERY.

MERCURY MODEL AIRPLANE CO.

1592-F.E. LINCOLN PL.

BROOKLYN, N. Y.

from where more Douglas bombers were attempting a getaway.

"What's that upstairs?" asked the Mick.

"Army guys in fighters. I gave Pebbles the word and she promised to go across to Hartford and call up Scott and warn him. We worked it so they would get men and machines out just in time to meet any of these guys who might take-off."

"We sure got away with murder on this one," the Mick beamed.

"The law of the righteous," added Keen starting down the face of the cliff.

They found the Bullet just as they had left her, and they quickly stripped her of the seaweed camouflage and started the Allison engines. They climbed in, moved her out, and waited as long as they dared to get the temperatures up. Then, with luck still on their side, they roared away down the sands, crawled up into a climbing turn and headed out to sea. They had no more than whipped around to get a better look at the hangar front when out of nowhere a flock of P-40's swarmed down on them. Keen rammed the mufflers out to get full benefit of his own power and ripped up into a mad climb. The Mick had his guns out and was writing a

daring pattern of defiance across the sky for the Yank airman to fly into.

They were young and were new at this sort of thing, and Barney's display held them off while Keen slammed the Black Bullet for the take-off stretch being used by the bombers. He relied entirely on the Mick and waited for the bombers to get into the clear. Then while P-40's swarmed all about them, uncertain as to what action to take, Keen dived the Bullet into a safety position behind a Douglas bomber that carried two green stripes and the markings "B1-93" on the fin.

The P-40's slashed in again, spraying metal, but the Mick plucked at their wing-tip pin feathers and made them hold off. The Douglas started after the others, but suddenly it swerved and Keen laughed aloud.

"All right, Lang!" he boomed with pleasure. "You keep that gun in his back and make sure he takes it to Mitchel. "We'll see that these Army boys don't bend your undercarriage!"

"Look out!" bellowed the Mick. "Here comes another Douglas!"

Keen twisted in his seat and then saw what was happening. Another Douglas had turned back after the one that was heading south. The gunners were blazing wildly at the one in

which Drury Lang was in command.

"I don't like to do this," said Keen grimly, "but I guess we've got to. We saved most of them by banging up their props, but I guess we've got to sacrifice one."

The Black Bullet went over with a roar and a scream of prop-slash. Keen nosed her down bluntly and then fingered for his gun controls. The Douglas slid into the ring sight and he depressed the trigger gear. The heavy caliber stuff up front barked and flamed out with jets of scarlet and deadly gold.

The slugs ate into dural, steel and fittings. A wing flopped up, carried a motor with it, and a flailing prop still screaming its wrath cut a great gash deep into the control pit. Flame ignited the fractured wing tanks and the Douglas torched herself and rolled over in flaming agony.

The doomed Douglas nosed over, gave a great convulsion, and fluttered down toward the sea.

From that moment on, the P-40's quit bothering the Black Bullet, and before they knew just what was taking place the mysterious machines went up in an amazing zoom and disappeared into the clouds above.

KEEN, Barney, and Miss Colony were enjoying the fire again that evening and listening to the radio account of an amazing situation that had taken place only a few hours before along the New England coast. To be fair, the announcers had most of the details correct, but they most certainly were laying it on a little thick about the daring and courage of one Drury Lang, a Government agent. They gave him all the credit for the great capture of a band of sabotage agents that had stolen a complete squadron of American bombers and had drawn up a plot to blast every U. S. military field and aircraft factory off the map.

Fortunately, the radio announcers were not explaining how this Drury Lang happened to be in the thick of all this mess and how he got aboard a certain bomber which had brought him back safely.

They were enjoying a round of Planters' Punches and listening to the details of the adventure when the phone rang.

Keen picked up the receiver and put on a bored air. It was John Scott.

"That you, Keen?"

"Why do you get me out of bed and ask that?" demanded the gunning Harry.

"In bed? You're supposed to be the Griffon. You're supposed to be in Hartford telephoning *me*. You're supposed to be up at Great Wass island capturing sabotage agents."

"I was," Keen said with amazing calm. "That's why I'm tired and deep in slumber. What's all this about, anyway?"

"Look," Scott went on. "You're Kerry Keen and you can still be the Griffon. You could have been at Hartford or up at Great Wass, but I don't for a minute believe you were."

Test Yourself

- Who built the Air Corps AT-5A?
- How do skywriters work?
- What is an aviation "Wash Room"?

IN EVERY issue of **FLYING ACES** you'll find articles, stories, photographs, departments, and model features which answer many aero questions. Next month's number is typical—it defines the above questions and many others. And what's more, we'll present one more feature article than ever before!

Don't miss the June issue of F.A. ! If you are not a subscriber, take advantage of the Special Offer below. If you already subscribe to **FLYING ACES**, perhaps you would like to get a subscription for a friend.

Special Introductory Offer

9 Months of FLYING ACES for \$1.00

Add 20c for Canadian subscriptions; 60c for other foreign countries.

Fill Out and Mail Now

Subscription Dept., **FLYING ACES**
67 West 44th St., New York, N. Y.

Enclosed is \$1.00 for the next 9 issues of **FLYING ACES**. Start with the
..... number.

Name

Street and No.

City State

"So! Now I can go back to bed again?"

"Sure. Go back to bed and dream sweet dreams. You did a good turn somewhere tonight. We'll never know, and between you and me, Keen, I don't care whether we do or not."

"Scottie, old boy, Miss Colony has been here all day. She doesn't know what you are talking about. I'll put her on and you can ask her for the

truth. Here, Pebbles, tell John Scott what I was doing all day today."

The girl took the phone, smiled sweetly, and said: "Hello, Mr. Scott. You should have been here. We had quite a beach party."

"Well, I'll be!" gasped Keen, flopping over on the settee

"I think I'll get me a drink," said the Mick.

THE END

WINDJAMMER

(Continued from page 50)

cement hardens. Later, remove these pins. As soon as the lower wing sets are fast, cement the center strut in position as shown.

In the meantime, cement the upper wing panels together by raising the wing tips to the required height. When ready for handling, lift carefully and place atop the center wing strut and cement once more. Insert a pin or two through the wing center into the strut itself.

The next step is to cement the outer wing struts in their proper positions so that they fit perfectly between the upper and lower surfaces. Use the cement to fill in the crevices between the surfaces. Place small "prop" blocks at the extreme wing tips to balance the model while all the cemented parts dry.

The completed craft as is, is without a balancing point. To trim the model, use either Scotch tape or reg-

ular adhesive. Some model builders prefer to use putty. If that is not obtainable, Scotch tape is the best substitute as it may be purchased at any five and ten cent store.

Wrap as required to make the glider nose heavy. In the meantime, you may try gliding its nose down slightly. Add or remove the amount of weight applied to the nose as the case necessitates.

When the correct amount of weight has been found, try the ship outdoors using the launching stick. The take-off climb will give plenty altitude so its characteristics may be studied. The launching stake is a simple affair composed of a hard stick with a double strand of 3/32" flat fresh rubber tied to one end. The loop should be about a foot long. The stake can be planted into the ground or held in the hand of an assistant.

When launching, bank the craft slightly to right or left. By testing, you can determine just which way the ship reacts and how much catapulting it needs.

THE END

DAWN PETROL

(Continued from page 34)

Oberst will be mad."

"Bah mit der Herr Oberst. Some day der Junkers vill findt themselves where idt ist where they belong," the little Kraut pouring over the map growled. "Was ist? I hear somedings vunce!"

Phineas heard it, too. He had made the noise himself. The dip into the canal was having its say. He got set to sprint but the sneeze had aroused a sleepy Boche lookout. He leaped toward Phineas and the pigsticker on the end of his gun barrel stopped within a quarter of an inch of the Pinkham jugular.

"Quick. Der map. Hide it vunce!" a voice came out of the window.

"I give up," Phineas yipped. "Did I even start a fight? We gates, Hans. I am on the wrong side of the tracks and I demand respect as I am an orfiser besides bein' a prisoner of war. Where is your boss?"

"Raus mitt!" the Boche shoved out. "In der houze, undt mach schnell."

"Awright," Phineas snapped. "I'd rather be a quick one than a dead one. Haw-w-w-w-w-w!" The Yankee flyer walked in on the other Heinies with

a bayonet tip breaking the fabric at the seat of his pants.

"Loogk, unter-offizier. A prisoner I findt. So now we vill notd gedt der punishment for eating up der food, ja?"

Phineas tried to figure out the status of the small Boche patrol. They had an officer's coat and hat in the hut. The little Heinie had a map and he talked about fuel. Possibly there was truth to the rumors that the Krauts were beginning to turn on their superiors. Perhaps this bunch of stragglers had knocked off a Junker and had gone on their own.

"Where is der ober-offizier?" Phineas wanted to know when he was pushed into a chair.

"I am in command, mein freund," the Heinie with the spinach under his nose said arrogantly. "The coat you see? We find it here, ja."

"Undt he likes to wear der coat undt hat undt think he is der big German commander, ha ha," a little Boche dough said, nodding toward the Kaiser's non-com. For his pains he got a swift kick in the slats and a buffet on his iron derby that sent ringing sounds through his noggin for the next three days.

"Ist it funny to anybody else, hein?"

"Don't fight," Phineas grinned. "Where is the nearest real Herr

REAL ENGINE VALUE



G.H.Q. GAS ENGINE KIT
NOW ONLY \$4.95

Identical Engine less Coil and Condenser \$3.95

This is a miniature gasoline engine that really operates. Mass production methods and enthusiastic reception have enabled us to reduce the price from \$35.00 originally to the NEW LOW PRICE OF \$4.95. Over 15,000 sold in the last year—over 50,000 in use today. THE NEW IMPROVED 1941 MODEL KIT is ABSOLUTELY COMPLETE with coil, condenser, plug, simple illustrated instructions, gas tank, etc.

For Model Planes, Boats, Midget Cars.



All Parts Finished and Guaranteed.
All Machining Done.
No Mechanical Knowledge Required.
1/5 Horsepower; NAA Class C Engine

Average assembly time 30 minutes.
ONLY A SCREW DRIVER NEEDED

FACTORY ASSEMBLED \$6.50
READY-TO-RUN
Complete with Coil and Condenser

Dealers Wanted
Send for FREE literature or 6c for Jumbo catalog.

SEND ONLY \$1.00
Shipped Collect, C.O.D. Same Day.

G.H.Q. MOTORS, Dept. F, 40 East 21st, New York

TYPEWRITER 1/3 PRICE

STANDARD OFFICE MODELS
1/3 MFRS. ORIG. PRICE
Easiest Terms: 60¢ a Week

as Low as 60¢ a Week

All late models completely rebuilt like brand new. FULLY GUARANTEED.

No Money Down—10 Day Trial

Free price-smashing catalog shows all makes in colors. FREE COURSE

IN TYPING INCLUDED. See catalog before you buy. SEND NOW

INTERNATIONAL TYPEWRITER EXCH.

Dept. 583 231 W. Monroe St., Chicago, Ill.



10c A DAY

COLT 45 CAL. Frontier Model

Basswood construction kit with working plans and all necessary hardware. Barrel and cylinder are machined. \$1.45

COLT 45 Cal. "FRONTIER" model kit, \$1.55

COLT 45 Cal. "FRONTIER" model kit, 7 1/2" barrel 1.70

COLT 45 Automatic Pistol kit 1.00

COLT 25 Cal. automatic pistol kit50

THOMPSON SUB MACHINE GUN model kit \$3.00

Savage Cal. 32 automatic pistol kit75

LUGER 9 M/M auto. pistol kit w/4" barrel 1.75

LUGER 9 M/M auto. pistol kit w/6" barrel 1.90

All kits make beautiful full scale models. Postpaid in U. S. A.

GUN MODEL CO. Dept. FA-5, 2908 N. Nordica Ave., Chicago, Ill.



PILOTS, STUDENTS, MECHANICS, HOBBYISTS—IDENTIFY YOURSELF WITH AVIATION. BY WEARING THIS HANDSOME GOLD PLATED, WINGS, MOTOR AND PROP PIN . . . WORTH 45¢

Send 25c for the pin and receive free our new catalogue of aviation jewelry, aircraft sketches, over 1500 aircraft photos, books, etc., or send 3c for catalogue.

CRAFT ART COMPANY DEPT. L
246 FIFTH AVENUE, NEW YORK, N. Y.

Oberst as I want some mess?"

"We go now," the Kraut corporal said. "Sooner as the better."

PHINEAS had no tricks with him. There did not seem any way of getting out of this one. And if he did, he would be dumped out of the kettle into the frying pan, for a court-martial was waiting for him on his own side. His brain had to do double duty.

"Where are we?" Phineas asked. "Anywhere near Deidenhofen?"

"*Nein*. Ha, ha," the Boche corporal laughed. "Not yedt so close as siggdy miles."

"Well," Phineas told himself, "it is one time I will not pay off with a big stunt for the Allies. I might as well be resigned and go to the prison camp."

There was a hasty huddle on the part of the Boche. When it was over, the one who had a smattering of English told Phineas to doll up in the Kraut brass hat's greatcoat and hat.

"We take no chances of der Kaiser's flyers taking der prisoner away from us," the Jerry with the lip curtains said. "Too much is at stake. I haff der monocle I findt in der coat, too. *Comst du hier*, Ludwig, undt giff idt to me der lock of hair you carry of der *fraulein* in Saxony."

"*Nein*. Nodt for all de marks—!" Kerwhop!

A few moments later, the strange Jerry non-com took a little tube of glue out of a tattered leather case he carried. He pasted a lock of a German canary's hair over the Pinkham upper lip and put glue on the ends of the false mustache so that they would stay in a curled-up position.

"Haw-w-w-w-w-w-w-w! A page from my own book," Phineas grinned. I heard you bums were copy cats. All right, giff idt here der monocle. I am der Heinie brass hat until you get to your C.O., huh?"

"*Ja*. Der Junkers would steal der aviator undt say they captured him undt gedt der medals. We haff to pass by der airdrome maybe on der way."

The coat and hat fitted Phineas to perfection. He rubbed dust on his face to hide his freckles.

"Er—just a minute," Phineas gulped. "If I am caught in a Boche union suit, I will be standin' up against a wall before I know it and will not be waitin' for a street car. I am takin' off this suit right now an'—"

"*Ja?*" a Boche said. He jabbed Phineas in the empennage with his saw-edged bayonet.

Phineas wished he had never heard of the omelet trick. Fretting dew oozed out of his epidermis and his undercarriage wobbled. If only there was one little trick up his sleeve! The Boche had fleeced him, had found his dog tag, an old chocolate bar wrapper, and a band off a cigar he had given Bump weeks ago. The letters on the band said: EL STENCHO IMPER-FECTO. A fall guy only got the stench for a while, then the cigar always blew up.

LET US NOW go upstairs and look in on the crew of a Kraut bomber that was having a time getting back to Hunland after having been smacked by Archie hardware. The Kraut at the racks was for unloading but the pilot remembered the orders he had been given from his superior. *Bomben* were scarce in Germany, and if a load could be returned that had no chance of biting into an Allied vital spot it had to be.

"Bah!" the Boche at the controls said. "I can gedt der Gotha back if idt keeps one ving undt der tail on. Der Fatherland expects efery man to obey-der orders. Tomorrow nacht we go ofer mit der *bomben* again undt get der ammunition dump by Pagny yedt. I vill land der Gotha light as if idt was der goose down undt not der plane. Ha. Idt ist der joke. Am I nervous, Herr Schloppts? Loogk, I efen smoke der zeegar while I fly der Gotha!"

"*Himmel*," the Boche with the pilot gulped. "A piece of shrapnel idt hits you, *Leutnant*. Maybeidt ist better I take der vheel, *hein?*"

"*Dumkopf!* I giff der orders. Light idt for me der zeegar. Hah, such ein aroma. From der Britisher Hauptmann who my cousin Heinrich shoots down mitt der Fokker giffs to Heinrich undt Heinrich rides all der way from Hambach to giff his cousin. No hardt feelings has Heinrich if I do take his *fraulein* in Aachen."

"*Ja?*" the Boche said, holding the flame from a clumsy Boche lighter to the end of the cigar. I bedt you I know you haff der cousin named Heinrich. *Ach*, der Gotha flies like der lame goose, *Leutnant*."

"El Stencho Imperfecto, *hein?* Das ist Spanish, Schloppts. Nobody makes der better zeegars. Ah, iff der oil undt burning fabric on der ving didn't smell so bad, I could smell der sweetness of der Havana undt—"

BOOM!

"*Himmel! Donnervetter!*"

Sparks flew everywhere. They went down into the catwalk and sprayed the face of the jittery Kraut at the toggles.

"Fire vunce! *Ach du lieber*. Ofer mitt der *bomben*," the egg-dropping specialist yowled and yanked the bombs loose.

"Der zeegar was loaded, *nein?*" the Gotha pilot howled. "So smart ist der beef-eaters, *ja?*"

"Land der ship, *Leutnant!* Der ving is getting crooked. Undt you was going to land mit der *bomben*. Bah! I am only der *unter-offizier*, but loogk vunce. I giff you der punch right in der faze! So!"

Putting bees in the pilot's head did not help matters. The Gotha swooped toward terra firma, a potential wash-out if there ever was one.

The bombs that had been dropped had to hit somewhere. One of them landed on the doorstep of the house where Phineas Pinkham was getting ready to walk to durance vile and worse. The Alsatian cottage did a two-step, a complete revolution, and then disintegrated. Boche flew in all

directions and Phineas Pinkham picked himself up two hundred yards from the bomb crater and coughed up pieces of turf with cordite fumes.

"I am out West this time," Phineas mumbled. "Nothing could live after that, not even a Pinkham. I will see coyotes and cattle grazin' when I open my lamps. I hope I am close to a camp where there is steak cookin'."

Lieutenant Pinkham opened his eyes and saw nothing that smacked of the Wild West or of its equivalent. He saw a Kraut dangling from a tree limb not far away and he could hear the Teuton swearing. The voice sounded like the corporal's.

Phineas, marveling at his stamina and iron-clad constitution, got to his feet and weaved his way across the German linoleum. He groped his way through enemy territory for a quarter of a mile before he came upon the Gotha. A miracle had happened but Phineas was not aware of it. The Heinie pilot had put the Gotha down intact except for the hole in the wing and the tatters in the complicated tail assembly. One Boche staggered toward Phineas, stopped and saluted.

"*Ja*. I hit both der bummers. Almost they are going to blow me up. I see der sparks undt let der *bomben* go. When der ship lands, *Leutnant* Schleppermann gets insulting undt I am so madt, so madt, *Herr Oberst*, I punch both der fellers. So I am on der way to der drome to give myself up, *ja*."

"*Raus mitt*. I vill talk mit der *Leutnant*," Phineas said. "Huh, a Gotha. The power plants are still tickin'. Wonder if I can fly it."

Phineas stooped over the Gotha pilot who was beginning to stir and nudged him with his own Luger. "*Raus mitt!*"

"*Hein? Ach, Herr Oberst*. Idt ist mutiny. I am smoking der zeegar—ah, was ist?"

"Get in the brains, you bum, or I blow your Gotha out. I mean— Well, I am desperate," Phineas tossed out. "Ist idt der prison camp in France or a boneyard right here, *hein?* I am a spy and have got nothin' to lose if that crate falls apart. Make snails! That is veet veet in Kraut, huh?"

"*Ja*. I am sick of der var meinself," Schleppermann clipped. "I fly ofer der lines, maybe. If der ship gets upstairs, *mein freund*, I will belief even about werewolves. Don't shoodd!"

THE BOGUS *Herr Oberst* and the Heinie climbed into the bomber. Schleppermann was some sky hackie and no mistake. He got the Gotha off the ground and it creaked and groaned and shivered as it just missed the tops of a line of trees fringing the wide pasture. Phineas closed his eyes, kept the gun against the *Leutnant's* ribs.

"Are we up yet?" Phineas asked.

"Hah! I can make der Gotha do der tricks like der Doberman Pincer, *mein freund*. Ist idt true you eat der huckleberry pie yedt mit der Allies. What ist der Kaiser's future against der pie?"

"You would cut up two lemons to make lemonade and then wonder why the lemons couldn't be used again. You are Scotch awright. Stop beefin'."

"The bombers are going over to that place tonight," the Old Man said to Phineas. "It is going to be just too bad if that map was a phony."

"Well it is my only ace," Phineas drawled. "If it is trumped, well—it was a swell guerre while I was in it."

The hours seemed to turtle past with anvils tied to them. Phineas sat in his Nisson, biting off his nails and soaking the hair above his upper lip with hot water. Pilots sauntered by to keep his courage up.

"I hope they have got a big fresh pile of rocks at Leavenworth," Howell said.

"There is a solitary cell there where six prisoners have died," Bump offered. "It is worst than the place where they locked up the Count of Monte Christo."

"Awright, bums," Phineas yipped.

"If I ever get free again, look out!"

"We are not worryin' as you cannot run fast with a six-foot white beard," another pilot twitted.

More hours went by. It was seven o'clock the next morning when the news hit the Ninth Pursuit Squadron. Over at Etzerbruck a fire was burning. It was big enough to melt half the real estate at the North Pole. Yes, the bombers had hit a Heinie fuel center dead on the nose.

A Handley-Page pilot's report had been: "We spotted that place okay. It was camouflaged some but when the Boche shrapnel started coming up, we knew we were not over a dill pickle works. Boys, what a fire! Couldn't you see it from here? There was enough gas stored there to fuel a thousand Fokkers for two years, I'll bet. Where did that aviator get that map?"

Phineas Pinkham was not let out of durance vile until late in the afternoon. Major Garrity wanted every-

thing confirmed at least six times. Reconnaissance planes went over the ruins of the Heinie pep juice concentration that day and brought in their testimonials. A car load of brass hats arrived at the Ninth and they gave the C.O. a pretty going over for keeping a hero under guard.

"How did you get that map, Pinkham?" a Brigadier wanted to know. "Amazing, I'll say."

"It is kind of hazy to me," Lieutenant Pinkham said. "I met some Boche doughs and they dressed me up in Kraut clothes so no Kraut airmen would steal me. It looked like I was cooked until a Gotha flew over and unloaded its eggs. I got separated from my hosts and came on the Gotha where it was put down. I made the Kraut fly me home. I got the map from the pocket of this coat. It was where a Heinie non-com hid it when I stumbled over the house where he was lookin' at the map. I wish I knew where he got it. Haw-w-w-w-w-w-w!"

"It doesn't make sense, does it, Major?" the Brigadier said.

"I am glad a brass hat agrees with me for once," the C.O. said sourly.

"I need a smoke, Major. Left my pipe somewhere," the bewildered brass hat said.

"Bump," Phineas said, "I gave you a cigar awhile back. Have you still got it?"

"That rope!" Bump snorted. "You think I was born an hour ago? I give that to a Limey flyer in Commercy one night. Too bad about him. He was shot down behind the lines a couple of weeks ago."

"Well, it is all I know," Phineas grinned. "If it is awright, I would like some mess and then some more sleep."

OVER in a little dugout in a communication trench behind Damvillers, a Boche non-com sat on a potato masher case and gnawed at his knuckles.

"Ach! I make der map of what I will do when der time comes," he said. "Idt ist at Etzelbruck I figure ist a good place to store der fuel for der war planes. So idt ist der same place where der High Command in this *krieg* puts it all in one bunch for der big air drive, ja. Undt I didt nodt know. Idt is der smart Junkers' fault keeping eferyt'ng secret from der low borns like me. Bah! Gut enough for der bammers! Ach Himmel! If I hadt nodt hide der map in der coat. If der Gotha—Vell, I will draw another map for *der tag!*"

After eight hours more sleep, Phineas Pinkham felt in the proverbial pink. He had the world in a jug again and had the stopper in his hand. He sat in his Nisson wondering what he would do with three more medals and he had his eye on the Boche brass hat's skimmer he had for a souvenir. The hat was on the table, upside down. Phineas' sharp peepers saw the corner of a letter peeping out from the sweat band. He retrieved the letter and saw that it was written in German. The post mark was

Aero Book Reviews

Any volume described in this department may be obtained, at the price quoted, direct from the publisher named and at the address given. When writing for a book kindly mention that you saw it reviewed in FLYING ACES.

By a Famous Editor

Report on England: November, 1940, by Ralph Ingersoll, Simon & Schuster, 1230 Sixth Ave., New York City, \$1.50.

Ralph Ingersoll, who is the editor of New York City's newspaper *PM*, made a special trip to England to see for himself exactly how the British were carrying on the war against Hitler. When he returned to this country, Mr. Ingersoll wrote of his experiences in a series of articles for his newspaper, later rewriting them in greater detail for presentation in book form. The result of that work is *Report on England: November, 1940*.

Even though a great part of this book has nothing to do with aviation, the sections that do present air material more than make up for it. Further, the entire book will be of great interest to the flying fan. For if you're interested in aviation, then you're surely interested in war flying. And if you're interested in war flying, then you very definitely are more than just mildly interested in war as a whole. And since this is true, *Report on England* will keep you literally spellbound from cover to cover.

Chapter ten, if we must boil everything down to its bare form, is probably the best for aero students. The heading is "Can Our Planes Fight?" The answer to this, according to Mr. Ingersoll,

is no. He gives four reasons why American machines do not match those of the British or German. That, your reviewer believes, is definitely open to debate, but Mr. Ingersoll gives good reasons for his line of thought.

War in Africa

Roman Eagles Over Ethiopia, by Colonel P. A. del Valle, The Military Service Publishing Co., Harrisburg, Pa., \$2.50.

Here we have still another military book—this time, though, on the other side of the fence. Colonel del Valle, of the U. S. Marine Corps, was one of the few foreign eye-witnesses from the beginning to the end of Signor Mussolini's Ethiopian campaign, and he gives a straight, accurate account of what happened when the Fascist legions entered Haile Selassie's empire.

Colonel del Valle explains the events that led up to the campaign and how the war was carried out, step by step, from the first operations up to the final victory of Il Duce's armies.

Roman Eagles Over Ethiopia is a very excellent book and is the first volume dealing with that African war your reviewer has seen. All phases of the battle are explained in detail, with numerous clear, explanatory maps showing the operations undertaken by both the Italians and Ethiopians. Also, there are several photographs showing Italian generals who commanded the Fascist forces.

Unfortunately, Americans are usually prone to look at only one side of a question or war when the consensus is for that side. However, this book is highly recommended for all open-minded persons who are interested in how instead of why.

(Also see pages 63 and 72 for other reviews)

Austria. Phineas went over to the Operations shack and asked for the R.O.

"He knows Heinie," Phineas said to Major Garrity. "Maybe this will tell us somethin' about who had the map. It is a letter to the Herr Oberst who was maybe bumped off by his own men, huh?"

The Recording Officer put on his cheaters and squinted at the scrawled writing. He began to read:

"Dear Son:

It is too bad there is such a big war. There is a lot of work here in Braunau for good paper hangers, too. Papa is not mad at you no more for painting the picture of the wild boar hunt on the side of the barn. Maybe, I still say to

papa, our son he might be a great artist some day. If I find the book about Napoleon I will send it to you. I hope you are keeping well, son, and that we win the war soon. . . ."

"I don't get no sense out of that," Phineas sniffed, as the R.O. stopped reading. "No paper hanger gits to be a big shot in Germany. Well, maybe it will come out in the wash some day."

"You just fell into a tar vat and came out holding an ice-cream cone, as usual," Captain Howell said. "And here I always said the Arabian Nights was crazy. I will read them again when I get back home."

THE END

PLANE TARMAC

(Continued from page 23)

9,500 feet (above sea-level, of course) for two spins, one to the right and one to the left.

Stalling my ship, I applied right rudder to force her into a moderate spin. In two and one-half turns I brought her out, the ship responding nicely to the controls. And since I had used only a few hundred feet of my altitude, I still had more than enough for another spin.

Once again I stalled, but this time I made an experiment which nearly proved to be my last. (Moral: Never, never experiment unless at a safe distance above Mom Earth.) Instead of applying rudder only, I also gave complete aileron control to the left, shoving the wheel over hard. This, of course, resulted in a very tight spin.

After completing four turns I tried desperately to bring her out, all the while losing precious altitude at a rapid rate. She quit spinning quite easy, but as I brought the wheel back I met trouble. She didn't want to take!

For some reason, I then glanced

at my airspeed—and nearly froze in my seat! The hand had gone completely around the dial and had started over again! To be truthful, she read 210. I had no barograph, of course, and yet I do not doubt that it was very close to that speed.

I say this much: I did not believe it possible for a light plane to pull out of such a terrific dive without shedding its wings. My instructor as well as my wife says that I had only a bare hundred-feet of altitude left when I pulled out.

On the instrument board of the Aeronca "50" it states in bold print: "Do Not Exceed 135 m.p.h." Now I do not claim a record for a power dive in a light plane, but I do claim that this is the truth.

DONALD RICH,
Madrid, N. M.

And we, Don, claim that your letter is a good lesson and we're shipping you your two fish-skins. You not only tell a swell story, but also give us another chance to point out that safety-first is still the best principle and that plenty of nothing under your wings is darn useful when you're trying something doubtful.

THE END

COVERING UP

(Continued from page 47)

surfaced stabilizer and rudder, it is best to give one side of it a thorough doping so that the panel can be pressed down upon the piece of paper, thereby eliminating the necessity of having to cover in stages because of the quick drying dope.

The fuselage requires a bit more care in covering than does the wing and tail, especially if it has a round or oval section. When the surface has changes of curvature, it will be necessary to cover it in many small sections, rather than one whole side at a time. Use sections as large as possible to simplify your work. Sometimes compound curves can be covered with paper quite successfully—if the tissue is moistened first.

DOPING TECHNIQUE

DOPE is applied with a brush in even strokes, the brushing being parallel to the wing ribs. The shrinker liquid should be thinned to a good brushing consistency, but it should not be too thin.

Silk differs from paper covering only in that the adhesive is applied to soak through the material itself instead of under it, as such cloth requires more dope to make it air-tight.

As with the paper, cut a pattern of silk slightly larger than the wing panel. Instead of doping the wing and laying it on the silk, lay the silk over the wing. The grain of the silk should run parallel to the spars of the wing. Tack the silk in place by applying a dab of dope through the covering at each end of the panel. Pull the silk tight between the two dabs, then fasten it along both ends of the wing. Work along the leading and trailing

FREE FIREWORKS with every purchase!
COMPARE OUR PRICES BEFORE YOU BUY
One Cent POSTCARD will SAVE YOU MANY DOLLARS!
Send for **\$655 Liberty Ball** ASSORTMENT
FREE CATALOG Over 1300 Pieces **\$2.85** NET
Your Dollar Buys TWO Dollars Worth
BALTIMORE FIREWORKS CO., INC.
6945 EASTERN AVE. BALTIMORE, MARYLAND

Announcing To
MODEL RAILROADERS-DEALERS
JOBBER-MANUFACTURERS
A complete line of Model Railroad Cast Metal Parts from one source. The most complete range of finely detailed scale railroad parts in the country. Almost anything you want in any of the three popular gauges—O—HO—OO. Dealers—Jobbers—Manufacturers! Write for detailed information and price list now. Send 5c for illustrated catalog on R. R. equipment.
SELLEY FG. COMPANY
1375 GATES AVE. Dept. 105 BROOKLYN, N. Y.

AVIATION APPRENTICES
AIR-MINDED Young Men Interested in Training for Entering the Well Paid Field of Aviation as Apprentices. Write immediately, enclosing stamp.

MECHANIX UNIVERSAL AVIATION SERVICE CO.
Wayne County Airport, Box 857, Dept. K5, Detroit, Mich.

COMET *The COMET* 54"
TAYLORCRAFT
GIANT WINGSPAN! GIANT VALUE!
Big 54' flying model of popular light plane! Accurately scaled down from the original. Kit contains many finished parts, excluding new features! Postage 25c; none if ordered from dealer.
NEW WARPLANES AND BOATS
Spitfire, Defiant, Messerschmitt, Stuka Dive Bomber, Destroyer, Aircraft Carrier, etc. 10c and 25c; at your dealer. Send 5c for NEW CATALOG.
COMET MODEL AIRPLANE & SUPPLY CO.
129 W. 29th St., Chicago—688 Broadway, N.Y.—Dept. F-5

AVIATORS!
PERSONAL ITEMS—JEWELRY—BOOKS—AVIATION NOVELTIES—ORNAMENTS—CLOTHING—ETC. FOR THE AVIATOR AND MODEL PLANE BUILDER.

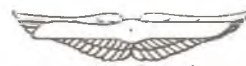
(Actual Size)
We are offering this pin and our illustrated aviation catalogue both for 25c—or send a dime and get the catalogue!
(Thousands of these pins have sold for 50c)

JOHN KEANE, 18 HARVEY ST., PHILA., PA.
Enclosed is 25c. Please send me that beautiful pin and FREE catalogue.
NAME
ADDRESS
CITY STATE

BIG CASH AWARDS FOR CAMERA FANS
Now is the time to get in on America's greatest hobby—amateur photography. Picture taking for readers of PRIZE PHOTOGRAPHY is twice as much fun. More than that—it's profitable. PRIZE PHOTOGRAPHY is the magazine for all picture takers. Here's why:
PRIZE PHOTOGRAPHY features five big picture-taking contests in every issue. Its exclusive pictorial articles tell you how to make good pictures. Simply follow the helpful tips these features contain and send in your pictures. You may win one of the many \$15, \$10 and \$5 prizes awarded each month. PRIZE PHOTOGRAPHY contains hundreds of striking pictures and data on how they were made. This big magazine printed magazine is America's Greatest Photo Value. Rush to your nearest newsstand now. It's only 15 cents a copy.
PRIZE PHOTOGRAPHY
15c—AT ALL NEWSSTANDS—15c

BUYERS' DIRECTORY

Airplanes and Accessories, Schools—
Flying Instruction
\$5 per inch—Payable in Advance

PATENT ATTORNEY

PATENT YOUR IDEAS

send a Sketch or Model
of your invention for
CONFIDENTIAL
ADVISE

FREE CONSULTATION
LITERATURE

Z.H. Polachek
REG. PATENT ATTORNEY
1234 BROADWAY
LONGBEACH 3, CALIF.

NAME _____
ADDRESS _____

PHOTOS

WARPLANE PHOTOGRAPHS!
Actual photographs of the latest U.S. Army and Navy aircraft, now available. Size 2 3/4" x 4 1/2".
5c each — 6 for 25c

Vought-Sikorsky XP4U-1 Martin B-26
Consolidated XPB2Y-1 Bell P-39
Douglas SBD-1 Consolidated XB-24

FREE New catalog listing over 1000 U.S. Military, Commercial, World War I and Foreign aircraft at 4c ea.

AIRCRAFT PHOTO SERVICE
3 Myrtle Court, Bridgeport, Conn.

CLASSIFIED DIRECTORY

Use this Directory for prompt response. Rate: 10c per word (minimum 20 words). CASH WITH ORDER. Make remittance payable to:

FLYING ACES
47 West 44th St., New York

AVIATION

AIRMINDED YOUNG MEN interested in training for entering the well-paid field of Aviation as Apprentices. See MUAS ad page 70.

Be A Detective

Make Secret Investigations

Earn Big Money. Work home or travel. Fascinating work. Experience unnecessary.

DETECTIVE Particulars FREE. Write **GEO. G. WAGNER**, 2640 Broadway, N. Y.

DEALERS—CLUBS

FREE LIQUIDS

In addition to our quality supplies and unsurpassed values, we offer you two

BIG—FREE DEALS

- On all orders from \$2.50 to \$5.00, 1 qt. of A-1 cement or dope (add 25c for packing).
- On all orders of \$5.00 or more, 1 gal. of A-1 cement or dope (add 75c for packing).

BALSA WOOD	2 oz. doz. 60c	WASHERS	1/8 or 1/4, 100 5c
36" Lengths Per 100	1 pt. 35c 1 qt. 60c	Shafts or Rear	Hooks . . . doz. 5c
1/32x1/16 . . . 10c	1 gal. each \$1.50	SHEET ALUM.	.002 thick, 5' 35c
1/16x1/16 . . . 10c	Thinner & Bana-	.005 thick, 5' 50c	.010 thick, 5' 75c
1/16x3/16 . . . 25c	oil same price	1/16 O.D., 5' 25c	3/32 O.D., 5' 28c
1/16x3/16 . . . 25c	COLOR'D DOPE	1/2 O.D., 5' 43c	1/2 O.D., 5' 30c
1/16x3/16 . . . 27c	All Colors	1/2 O.D., 5' 43c	WIRE , per 100 ft.
3/32x3/32 . . . 25c	1 oz. bot. dz. 50c	3/32 O.D., 5' 28c	Straight Lengths
3/4x3/4 . . . 30c	2 oz. bot. dz. 75c	No. 8 22c	No. 8 27c
3/4x3/16 . . . 50c	1 pt. 40c 1 qt. 70c	No. 12 32c	No. 14 37c
3/4x1/4 . . . 55c	TISSUE	No. 18 37c	
3/4x3/8 . . . 65c	White, doz. 10c		
3/16x3/16 . . . 50c	Colored, doz. 15c		
3/16x3/4 . . . 60c	BEST BAMBOO		
1/4x1/4 . . . 85c	1/16x1/4x12 dz. 2c		
BALSA SHEETS	1/16sq. x12 gr. 10c		
36" Lengths	MACHINE CUT		
1/64x2, 10 for 20c	PROPS , per doz.		
1/32x2, 10 for 15c	3" . . . 20c 6" . . . 21c		
1/16x2, 10 for 18c	7" . . . 30c 8" . . . 35c		
3/32x2, 10 for 21c	10" . . . 45c 12" . . . 60c		
1/4x2, 10 for 23c	M & M		
2/16x2, 10 for 32c	AIR WHEELS		
1/2x2, 10 for 42c	(For rubber cow-		
3/4x2, 10 for 75c	and models)		
1/2" widths are	1 1/2" . . . 13c 1 1/4" . . . 11c		
desired, double	1 3/4" . . . 15c		
price of 2" widths	1 7/8" . . . 20c 2 1/8" . . . 25c		
BALSA PLANKS	2 3/8" . . . 25c 2 1/2" . . . 23c		
36" Lengths	THW BEARING		
1x1 each . . . 6c	2 1/2" dia. . . 45c		
1 1/2 each . . . 9c	sim. dia. 6c gr. 55c		
1 3/4 each . . . 15c	lg. dia. 7c gr. 65c		
1x3 each . . . 20c	PARA RUBBER		
1x6 each . . . 35c	2 1/2" dia. . . 40c		
1 1/2x1 1/2 each . 25c	1/4 fat. 40c		
2x2 each . . . 25c	3/16 fat. 60c		
2x3 each . . . 35c	Per lb. \$3.10		
CLEAR DOPES			
1 oz. bot. doz 36c			
2 oz. bot. dz. 65c			
1 pt. 35c 1 qt. 65c			
1 gal. 1.75			
CLEAR DOPE			
1 oz. doz. 36c			

Dealers send for Complete Catalog. NO ORDERS UNDER \$2.50

Orders Shipped Express Charges Collect. On C.O.D. orders, send 25% with order, balance on delivery. Save C.O.D. charges, send payment with order.

MERCURY MODEL AIRPLANE CO.
1592-E, LINCOLN PLACE, BROOKLYN, N. Y.

edges with the dope brush, covering the whole length of the panel before pulling the silk tight across the chord.

After it has been laid all around, the silk can be pulled and worked over the edges with the fingers to tighten it.

The dope is applied exactly as it is on paper, brushing chordwise. Even strokes are of more importance here, however, as the silk is porous and must have all of the holes in the weave filled with dope. Two coats of dope are generally sufficient to accomplish this.

Silk covered wings should be given two coats of clear dope and then a coat or two of pigment which can be either brushed or sprayed.

It is well to remind you that before the first coat of dope is applied, the silk should be fastened to every bit of framework that it contacts by doping through the silk to the frame.

This is especially important with wings where, if the silk is not fastened to every rib, it will "bunch" when pressure is applied with the brush. The covering on the underside of undercambered wings should not be pulled as tightly as that on the top, to facilitate fastening the covering to the concave surface. If the silk is stretched too tight, it will tend to pull away from the ribs, making it necessary to use pins to hold it until the dope dries.

Where silk lays over a spar but does not touch it, the material must be filled before the shrinking coat of dope is applied. This is done by going over the silk above the spar with a coat of thick dope. Be careful not to let the silk sag and touch the spar. When the silk has been filled, the following coats of dope will not penetrate to the spar and cause the silk to stick to it when wet and sagging.

THE END

ARMY BC-1

(Continued from page 43)

be accomplished by adding five or six coats of dope to the cowling, and after they are dry dab another several coats of blue dope. Paint the landing gear flaps blue. Coat the propeller several times, and if slightly more weight is needed, use the inner trough of the cowling to accommodate small pieces of lead, solder, etc.

Trim the model by balancing it on your fingers. The balancing point should be right in front of the last.

The ship shown in the photographs

is equipped with celluloid wheels. These are a bit hard and noisy. A pair of balloon tired wheels of the same diameter may be purchased at any model shop. It is suggested that this kind may be substituted for hard wheels as they make for easier landings. Glide the ship until the best is brought out. Then follow up with minor power flights. Study its behavior and make any adjustments that are required.

For real flights, use a geared wind-er and stretch out the strands at least twice their length. Try take-off flights. They're really very fascinating to watch.

THE END

THAT AERO JOB

(Continued from page 29)

as Junior Engineers, commencing at \$2000 a year. Appointments are, of course, by examination, as are all Civil Service positions.

To summarize all that has just been said, regardless of what particular branch of aviation you may be interested in, the industry is expanding so rapidly that men are really in demand. In fact, there is a very definite shortage of trained and skilled labor in the country.

Of course, the War and the international situation have been the basic causes of this shortage in the manufacturing plants. North American is rushing production on 800 new British Harvard trainers, with a total backlog of more than \$60,000,000. Douglas is launching an employment program to increase their personnel to 17,000 the next Spring. They have a \$100,000,000 backlog. Similar stories hold true for Lockheed, Martin, and all the other large plants.

Aside from all the military activity, the air transportation figures are headed for the ceiling on all progress charts. Domestic airlines are report-

ing more interest in travel by air, and this interest is being translated into increased passenger-miles of travel. Reservations are being booked days in advance and some flights are being made in two, three, and even four sections.

The popularity of travel by air is probably demonstrated most vividly by the tremendous growth of transatlantic crossings which were started by Pan American Airways less than nine months ago. Already more than one hundred trips have been made with capacity mail and passenger loads, and plans are being made to increase schedules in the Spring.

Everyone realizes that aviation has become the most tremendous fact of today; it has compelled new ideas of the relationship of time and distance and has shrunk the world to one-sixth its former size. It has made neighbors of formerly widely separated communities and nations and it has revolutionized the habits of the world.

You are considering aviation and you can have a share in its development. You can have a part—an important part, if you choose—in the conduct of its affairs. The decision is for you to make.

THE END



WOULD YOU LIKE TO HELP KEEP GIANT AIR LINERS IN *flying trim*?

Not long ago these fellows were outside Aviation—as you are now. Today they are **INSIDE** Aviation—as maintenance men with the nation's great air lines—playing their part in keeping giant transports safely aloft . . . each day adding priceless experience to their solid foundation of Aero ITI training.

These men are only four of hundreds of Aero ITI-trained mechanics and engineers now making good in Aviation. Their Aero ITI training won them a "flying start" on their careers—for the Aviation industry has employed Aero ITI graduates as fast as they have completed their training.

Even **MORE** important than a starting job is the fact that Aero ITI training equips you with the broad, thorough technical knowledge and practical ability to make Aviation **YOUR LIFE WORK** . . . wherever you make your start—in aircraft manufacturing, air line operations, or aeronautical engineering.

Aviation is a permanent industry. Progress ahead is breath-taking. It is vital to obtain the **RIGHT** training for success—you can't afford to gamble on your future! Investigate the proven Aero ITI way to an Aviation career. Send the coupon in **NOW**.

**THAT'S WHAT
THESE FELLOWS
ARE DOING**

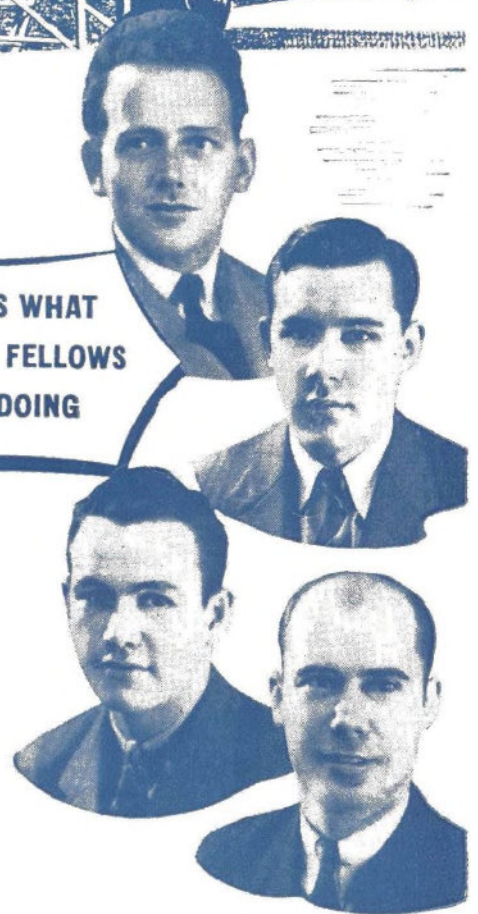

AERO INDUSTRIES TECHNICAL INSTITUTE

5266 WEST SAN FERNANDO ROAD . . . LOS ANGELES, CALIFORNIA

AERO INDUSTRIES TECHNICAL INSTITUTE
5266 West San Fernando Road, Los Angeles, California

Please send information on Aero ITI training for Aviation careers. I am interested in the following branch of Aviation: Aircraft Mechanics; Aeronautical Engineering; Undecided. Years High School: 1, 2, 3, 4. Years College (Liberal Arts): 1, 2, 3, 4. Years Engineering College: 1, 2, 3, 4.

Name _____ Age _____

Address _____

City _____ State _____ a-16-FA

Five Courses in
AIRCRAFT MECHANICS and AERONAUTICAL ENGINEERING
—Including 12 Month Aircraft Mechanics Course
Approved by U. S. Civil Aeronautics Administration

ADVISORY BOARD

ROBERT E. GROSS
President, Lockheed
Aircraft Corporation

JOHN K. NORTHROP
President, Northrop
Aircraft, Inc.

C. A. VAN DUSEN
Vice-Pres., Consolidated
Aircraft Corporation

Megow Models



SHOWN ABOVE

J-11. CESSNA-34
A 30" span, de luxe flying model of striking beauty 50c

D-9. RYAN ST.
50" span low wing flying model of Army trainer. \$1.50

THE HOBBIES THAT NEVER GROW OLD!

GAS MODELS for the CHAMPIONS

AERO-CHAMP

Very popular new type designed especially to take the "199" motor shown below. Easy to build. Small, light and sturdy for safe landings. Span 46". Kit E-21, less wheels and propeller 95c
Complete with motor, wheels, prop. and flight timer. \$14.95

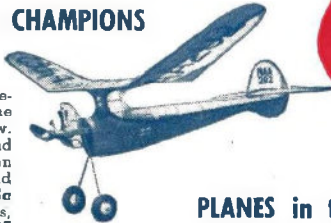

MEGOW "199" MOTOR

\$12.50 (with Coil and Condenser)

New 1941 model with new type ignition, new crankshaft and counter-balance. New timer with non-wearing cam. 5/8" size. 1/2 H.P. Wt. 3 1/2 oz.

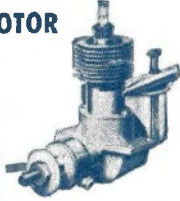

PLANES in the NEWS!

SPITFIRES
Favorite British fighters D-12. 50" Flying Models, \$1.00. C-31 - 23" Flying Models, 25c



STUKA BOMBERS
German dive bombers D-13. 50" Flying Models . . . \$1.00
J-17 - 30" Flying Models . . . 50c
S-44 small solid models. . . 10c



MODEL SHIPS

Extensive line of famous models, many with carved hulls. Ready-made parts and supplies.



HO- and O-Gauge RAILROADS

Exact scale, natural in appearance and detail. Flexible rubber roadbeds. Track sections and Trackside Equipment. Very extensive line.



D-11 AIRACOBRA

37" flying model of America's 500-mile-per-hour pursuit plane. Tricycle landing gear. All materials and plans \$1.00

One never tires of building Megow models. Boys of nine or ten start with the easier types, and as they become more expert soon start on flying models. Conquering that field, they begin building AERO-CHAMP or RANGER Gas Models that amaze all who see them perform. After that, if they do not get "drafted" by some big airplane company or similar industry, they will at least have skill that will be useful in a thousand ways.

No one ever outgrows Megow models. They step right along with progress in aviation, and reflect its latest achievements. New ones are always on the way. Boys and men of all ages are building Megow model airplanes, ships and railroads.

The big, new 132-page Megow catalog shows scores of airplanes, ships, model railroad equipment, parts, tools and supplies. Send 10c for your copy today!

AIR YOUTH MODELS

As licensed producer of "Air Youth of America" model kits, Megow offers five progressive types distinctly superior in quality and detail.

- No. 1. Hand-launched glider . . . 10c
- No. 2. Baby R.O.G. 10c
- No. 3. Senior R.O.G. 25c
- No. 4. Junior Commercial . . . 25c
- No. 5. Class C Contest Commercial 50c

MAIL THIS COUPON

DEPT. FA

with 10c postage for catalog, or enclose with money order or check for ordering above items by mail.

- | | | |
|--|--|--|
| <input type="checkbox"/> E-21 Aero-Champ | <input type="checkbox"/> D-12 Spitfire | <input type="checkbox"/> C-31 Spitfire |
| <input type="checkbox"/> "199" Motor | <input type="checkbox"/> D-13 Stuka | <input type="checkbox"/> J-17 Stuka |
| <input type="checkbox"/> J-11 Cessna | <input type="checkbox"/> D-11 Airacobra | <input type="checkbox"/> Catalog |
| <input type="checkbox"/> D-9 Ryan ST. | <input type="checkbox"/> Air Youth No. _____ | |

Include 15c post. for 37" or 50" models; 10c for smaller sizes.

Name _____
Address _____
City _____ State _____

Megow
HOWARD & OXFORD STS.
PHILADELPHIA, PA.
217 N. Desplains St., Chicago, Ill. - 718 Mission St., San Francisco, Cal.